

Appendix 3: Landfill Concept Design Report

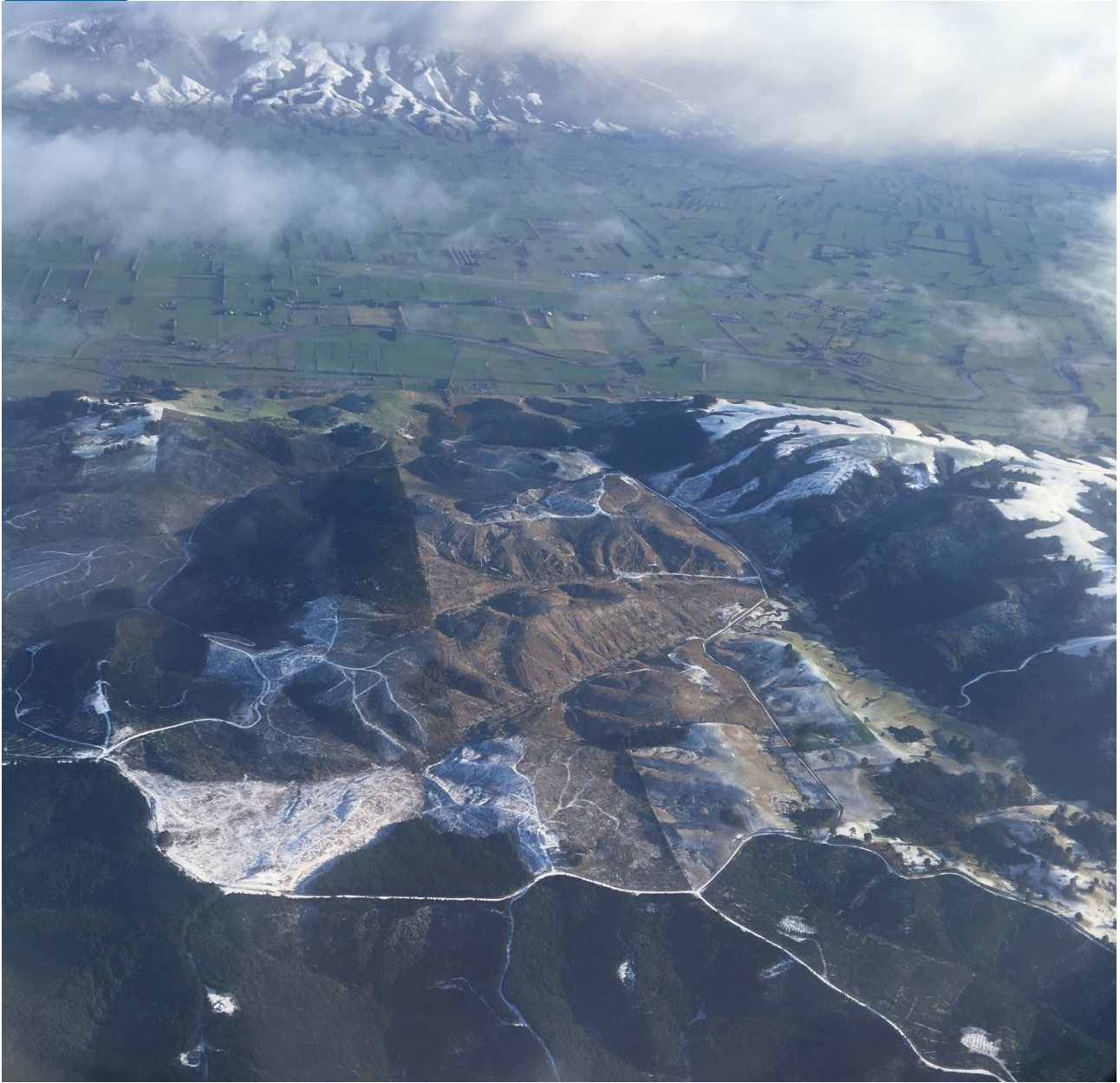

Dunedin City Council

Waste Futures Phase 2 - Workstream 3 Smooth Hill Landfill Landfill Concept Design Report



August 2020 ([Updated May 2021](#))

Table of contents

1.	Introduction	4
1.1	Introduction	4
1.2	Drivers and outcomes of the 2021 Design Revision.....	5
1.3	Landfill Purpose	6
2.	Site Description	7
2.1	Site Location	7
2.2	Site Ownership.....	8
2.3	Topography and Geomorphology	8
2.4	Climate.....	9
2.5	Site Geology	11
3.	Landfill Concept Design	12
3.1	Guidelines	12
3.2	Design Objectives	12
3.3	Project Description.....	12
3.4	Geotechnical Design.....	13
3.5	Formation Stability	16
3.6	Landfill Stability	16
3.7	Landfill Formation and Airspace	17
3.8	Overall Volumes.....	20
3.9	Landfill staging and operational life	21
3.10	Lining System	22
3.11	Leachate Collection	24
3.12	Leachate Management System Design Requirements	24
3.13	Final Capping.....	25
3.14	Stormwater Control.....	26
3.15	Subsoil Drainage and Groundwater.....	26
3.16	Perimeter Tree Planting.....	27
4.	Landfill Gas Management	28
5.	Leachate Management	29
5.1	Leachate Quantities.....	29
5.2	Leachate Quality	31
5.3	Leachate Collection	32
5.4	Leachate Storage and Management	33
6.	Ancillary Works	35
6.1	Operating Hours, Deliveries and Weighbridge	35
6.2	Site Roading	36
6.3	Site Facilities.....	38
6.4	Water Supply	39

6.5	Dust Suppression.....	40
6.6	Services	40
7.	Landfill Construction, Operation and Closure	41
7.1	Landfill Construction Activities	41
7.2	Initial construction activities	42
7.3	Operational Activities	46
7.4	Closure and Aftercare Activities.....	48
8.	Hazards and Contingent Events	50
8.1	Extreme Weather	50
8.2	Earthquake.....	50
8.3	Leachate Discharge to the Environment from above Ground Systems	51
8.4	Landslip.....	52
8.5	Attenuation basin dam failure	52
8.6	Landfill Fire	52
9.	Alternatives Considered.....	54
9.1	Landfill Designation Location.....	54
9.2	Landfill Size and Footprint	54
10.	Limitations	56
	This report: has been prepared by GHD for Dunedin City Council and may only be used and relied on by Dunedin City Council for the purpose agreed between GHD and the Dunedin City Council as set out in Section 1 of this report.....	56
11.	References.....	57

Table index

Table 2-1	Regional mean monthly rainfall (Updated May 2021)	10
Table 2-2	Mean monthly temperature and number of frost-days (Musselburgh)	10
Table 3-1	Landfill overall stability (Updated May 2021).....	17
Table 3-2	Factors of Safety.....	17
Table 3-3	Landfill capacity (Updated May 2021)	20
Table 3-4	Bulk earthworks volumes(Updated May 2021).....	21
Table 3-5	Landfill development filling rates (Updated May 2021).....	22
Table 5-1	Rainfall infiltration pathways	29
Table 5-2	Critical leachate storage volumes (Updated May 2021).....	30
Table 5-3:	Upper quartile of the highest leachate constituent concentrations	31
Table 5-4	Average leachate removal by tanker (Updated May 2021)	33
Table 6-1	Total truck numbers per annum (Updated May 2021).....	35
Table 6-2	Non-potable water use.....	39

Table 7-1 Waste Types47

Figure index

Figure 1 - Site Location (Updated May 2021)4
Figure 2 - Site Layout (Updated May 2021)7
Figure 3 - Surface Hydrology (Updated May 2021)9
Figure 4 - Geology Map.....11

Appendices

Appendix A – Landfill Gas Assessment and Concept Landfill Gas Management Measures

1. Introduction

1.1 Introduction

Dunedin City Council (Council) collects residential waste and manages the disposal of both residential and the majority of commercial waste for the Dunedin City area and environs.

The Council has embarked on the Waste Futures Project to develop an improved comprehensive waste management and diverted material system for Dunedin, including future kerbside collection and waste disposal options. As part of the project, the Council has confirmed the need to develop a new landfill to replace the Council's current Green Island Landfill, which is envisaged to reach full capacity [in the next few years. Final closure could be around 2028 depending on the closure strategy adopted by the Council](#).

The Council commenced a search for a new landfill location in the late 1980's and early 1990's and selected the Smooth Hill site in south-west Dunedin, shown in Figure 1 below, as the preferred option. At that time, the site was designated in the Dunedin District Plan, signalling and enabling its future use as a landfill site. The Council also secured an agreement with the ~~then current~~ landowner, Fulton Hogan Ltd, to purchase the land [and the Council took ownership of the land in September 2020. Since the 1990's](#), the Council extended the life of Green Island Landfill and further development of the Smooth Hill site has been on hold.

Figure 1 - Site Location (Updated May 2021)

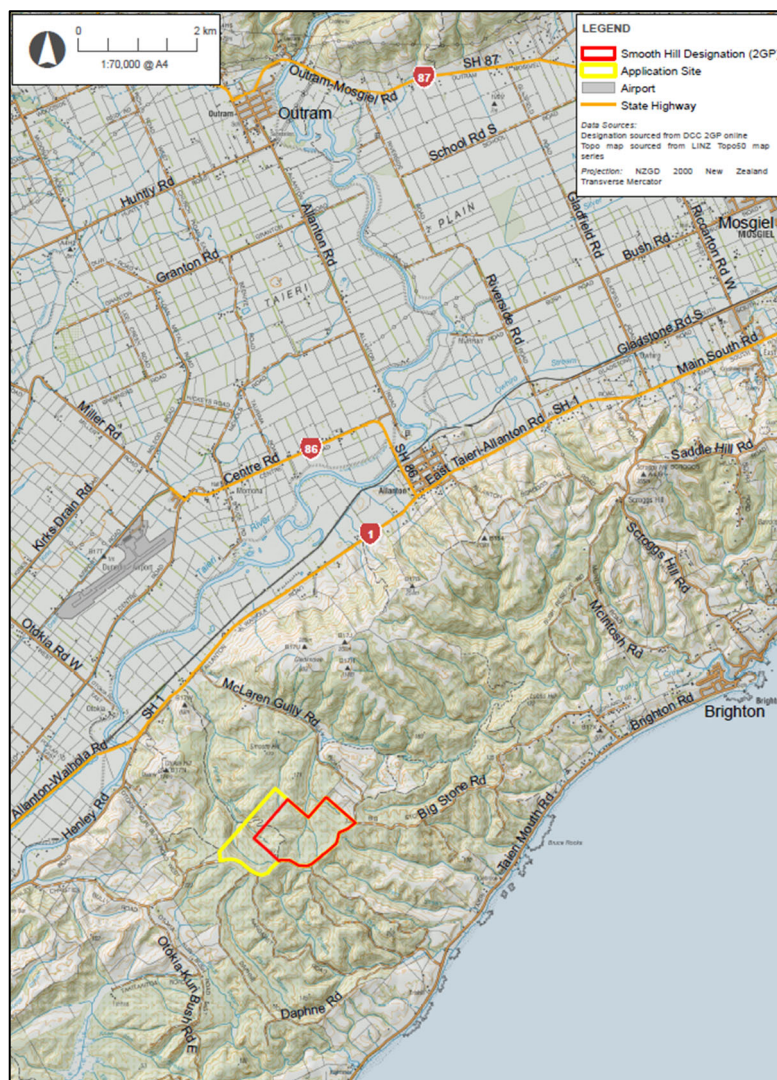

This report describes the engineering concept design of the proposed landfill. The design has been undertaken to a level to provide a basis for all specialist assessments of potential effects associated with landfill development and operation, and to define the general works proposed. The concept design presented herein will be developed into a detailed design for construction purposes once the Council makes the decision to move ahead with the delivery of the project at some time in the future.

1.2 Drivers and outcomes of the 2021 Design Revision

The Council lodged applications for resource consents for Smooth Hill Landfill with both the Otago Regional Council and Dunedin City Council in August 2020. The applications included an earlier version of this Design Report and the accompanying Drawings¹. The application was accepted by both regulatory parties and in October 2020 Section 92 (s92) requests were sent by the Council. The s92 requests included a range of questions in regard to the impact of the proposed development on wetlands and associated ecological environments. Both the landfill design and the upgrade of McLaren Gully Road presented in the applications had some direct impacts on wetlands. The s92 requests noted that this was of particular interest given enactment the National Policy Statement for Freshwater Management on 3 September 2020 (*Freshwater NPS 2020*) and the National Environmental Standards for Freshwater (NES Freshwater 2020) shortly after the applications were lodged.

Following the revisions to the design in response to s92 requests the Council has also continued to review the likely waste stream for Smooth Hill. The documents supporting the application had assumed an average waste stream of 90,000 tonnes per annum to Smooth Hill. However, review of recent data and assumptions regarding likely future increase in diversion has resulted in a revised estimate. The likely average waste stream is now assumed to be 60,000 tonnes per annum to Smooth Hill. Further discussion on the waste stream is provided in Section 7.3 of this report.

Based on the s92 requests and the revised waste stream estimate the Council requested GHD to review the landfill and road design and identify if a revised layout was possible that both avoid the extent practicable existing wetlands while still cost effectively meeting the future waste stream needs of Dunedin City. A revised design that largely meets these requirements has been developed and is presented in this report. The design has also been refined in response to other matters raised in the further information requests.

While being similar in many ways to the previous design, the key changes are summarised as follows:

- The landfill size has been reduced. The comparison between the previous design and the revised design footprint is shown on Drawings C102 and C104. The revised landfill lies within the footprint of Stage 1 and Stage 2 of the original design, with the western Stages 3, 4 and 5 no longer included. In overall terms:
 - The footprint of the landfill is reduced from 44.5 ha to 18.6 ha
 - Landfill (gross) capacity is reduced from approximately 7.9-million m³ to 3.3-million m³
 - Net waste capacity is reduced from 6.2-million m³ to 2.96-million m³
 - Based on the lower predicted waste generation rates (from 90,000 T/yr to 60,000 T/yr) the predicted landfill life has reduced from 55-years to approximately 40-years
- Practical adjustments to the general construction of the landfill, including:

¹ GHD. 2020. Smooth Hill Landfill Consenting – *Landfill Concept Design Report*. Project reference 12506381

- Landfill staging and construction sequencing, to a more typical 'bottom-up' filling methodology, which improves the intermediate and overall landform stability of the new design (Drawing C210 to C214)
- Leachate containment and collection systems adjusted to reflect the revised construction sequencing
- Construction phase systems for stormwater diversion, treatment and control
- Relocation of the attenuation basin to the west of the revised landfill footprint rather than immediately downstream of the landfill toe.

4.21.3 Landfill Purpose

As discussed later in this report, the landfill will be developed as a Class 1 Landfill and will only receive waste from commercial waste companies or bulk loads (not open to the public). The Council's waste reduction objectives and policies are that the rate of waste stream-generation will diminish over the lifespan of the landfill. ~~However, population growth is likely to add to the waste stream over time. Therefore, the~~ An assumption of this report has been made is that the ~~current~~ average annual waste stream received into the landfill from the Council of will be approximately 9960,000 tonnes per year ~~will be maintained for over~~ the life of the landfill. It is important to recognise that waste streams may vary significantly over time from this assumption and the concept design presented in this report allows the landfill design to be adapted in response to changes in waste stream volumes. This includes consideration of the need to allow for resilience in landfill capacity for future regional redevelopment scenarios or unforeseen events such as natural disasters, which can result in unexpected peaks in the rates and volumes of waste being generated. This issue is discussed further in Section 3.7.1.

2. Site Description

2.1 Site Location

The site is located approximately 28 km south-west of central Dunedin in the hills between State Highway 1 (SH1) and the coast. Access from SH1 is via McLaren Gully Road and Big Stone Road to the south-eastern boundary of the site. Both roads are currently unsealed. The site is bounded to the north and west by forestry land and to the north-east by pastoral farmland (Figure 1 and Figure 2). Within the site, access is via a series of forestry roads and tracks. Most of the site has been logged and re-planted in the past 5 years, although [a large stand of Macrocarpa remain in the south-east part of the site \(Figure 2\)](#) and [minor](#) areas of remnant native vegetation occur in the gully bottoms.

The archaeological remnants of two buildings have been identified within the site. The locations are shown on Drawing C102 and [are](#) discussed further in the Archaeology Report.

The site is currently un-serviced. Electricity and telephone lines extend 1.1 km along McLaren Gully Road (from SH1) to two existing houses (shown on Figure 2).

Figure 2 - Site Layout (Updated May 2021)

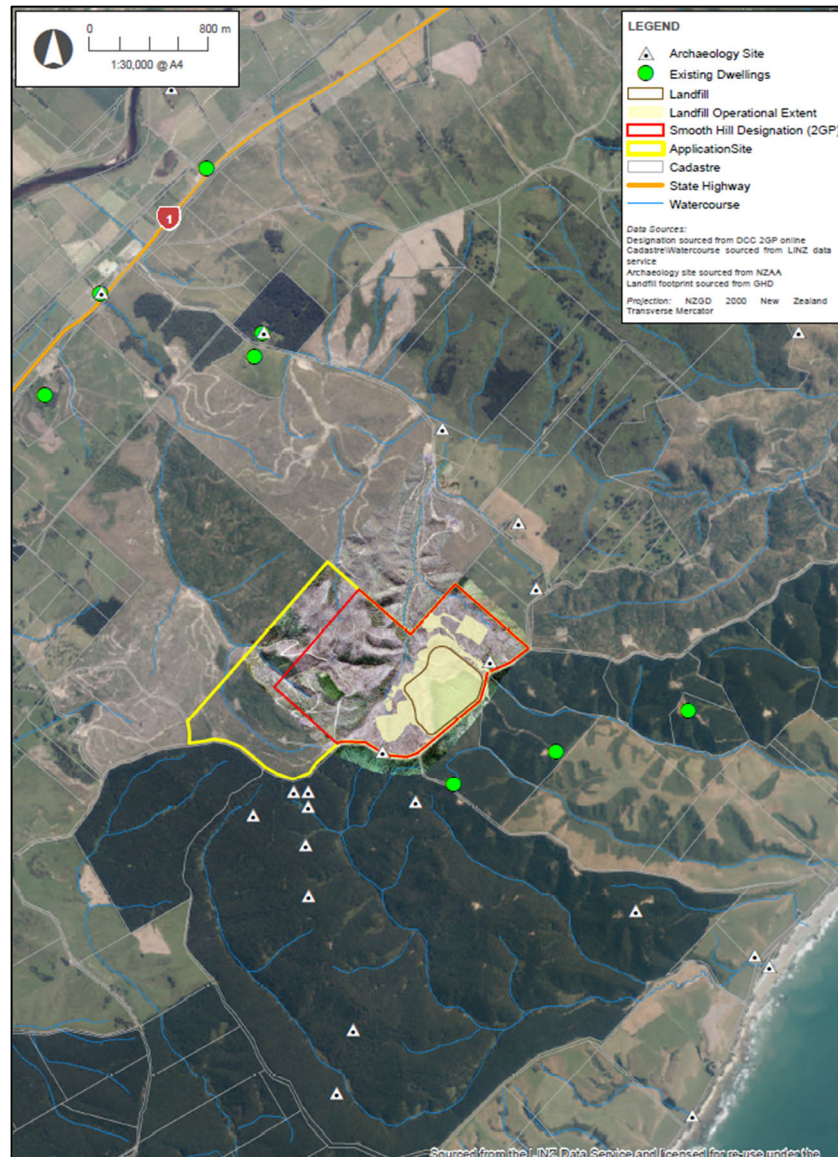

2.2 Site Ownership

The site is now owned by Dunedin City Council. Previously it was owned by Fulton Hogan Limited (FH). The Council had an agreement with FH to purchase the designated land and took ownership in 2020 after the applications were lodged. In addition to the designated land purchase from FH, Council is also in discussions to purchase land to allow road corridor upgrades, including the widening and upgrade of the SH1 junction, McLaren Gully Road and Big Stone Road to the site entrance.

2.2.3 Topography and Geomorphology

The landfill site is located in a natural “amphitheatre”, which is bisected by a larger central ridge and a smaller ridge in the south-western corner – both trending south to north – see Drawing C103 Existing Contours. The site typically has side slopes of 20%. A south to north system of gullies passes through the site, which are dry most of the year with flowing water only after rainfall. The gullies coalesce into a single gully at/near the northern edge of the site, and join a sequence of wetlands. The wetlands are connected by a defined channel that appears to be perennial or likely to have surface water present all or most of the year. However, during dry periods such as over the 2020/2021 summer, surface water flow ceases as far downstream as at least the culvert beneath McLaren Gully Road. permanent stream to the north of the site. Further downstream from the McLaren Gully Road culvert, the stream joins the Otokia Creek that ultimately flows to the coast near Brighton, approximately 10 km north-east of the landfill site.

Big Stone Road runs along a ridge on the south-eastern edge of the site and is the catchment divide. To the south of Big Stone Road, the land drains directly to the Pacific Ocean via a series of gullies and streams (from north to south Graybrook Stream, Fern Stream, Tutu Stream and Flax Stream – Figure 3).

The lowest elevation within the landfill site is the base of the gully at Reduced Level (RL) 100 rising to the ridgeline on Big Stone Road typically RL 140 to RL 150 and up to RL 180 in the southwest corner of the site.

Figure 3 - Surface Hydrology (Updated May 2021)

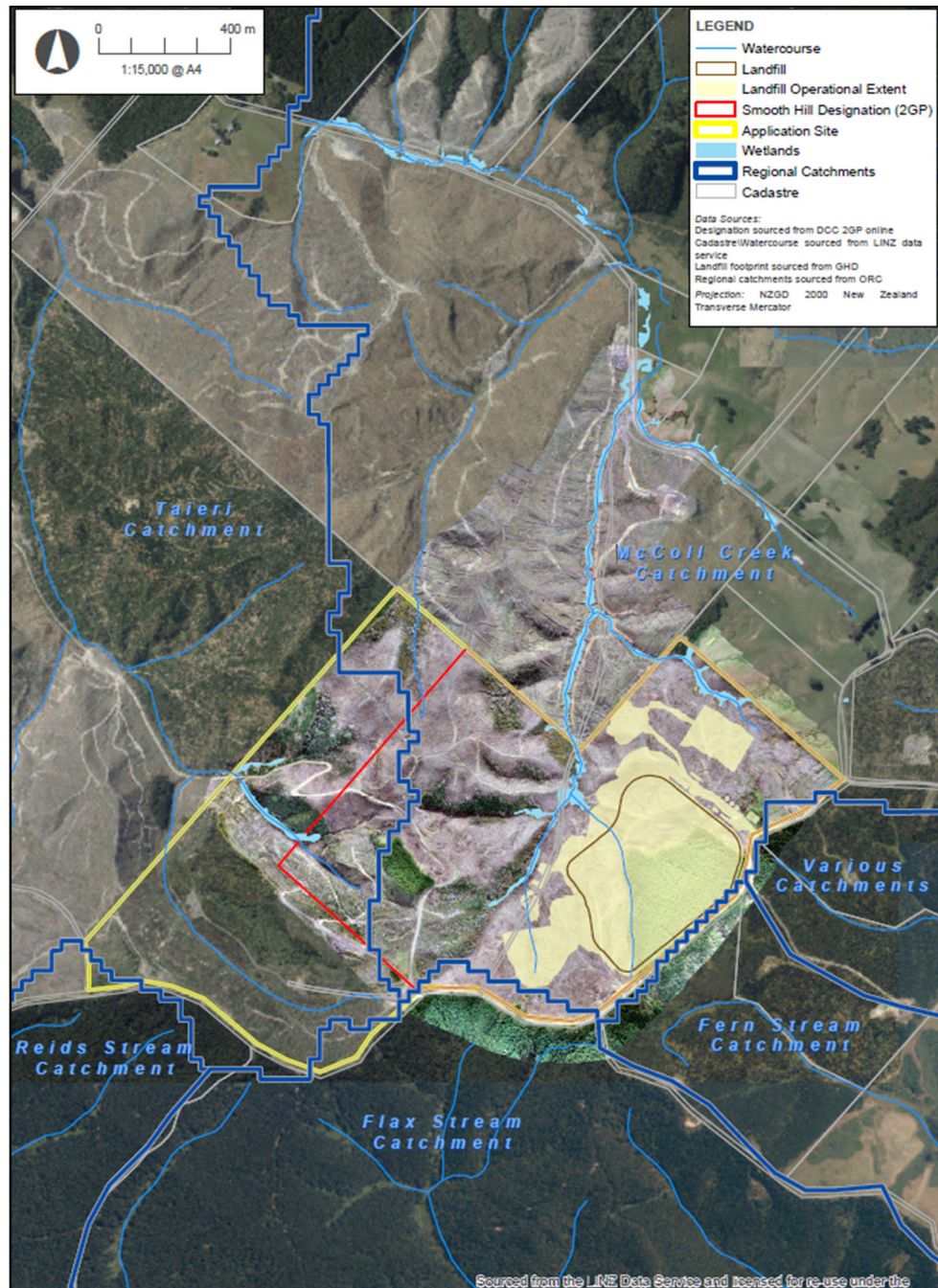

2.32.4 Climate

2.4.1 General

General climate data for the area derived from NIWA 2015 “*The Climate and Weather of Otago*” indicates the climate of this region is temperate climate ~~the following of the site. The climate of this region is temperate climate.~~ The regional mean monthly rainfall is presented in Table 2-1. The winter period of June to September is slightly dryer with rainfall between 42 mm and 47 mm per month. The wettest months are December and January. Monthly rainfall is between 63 mm to 96 mm. Annual rainfall for the 2018 to 2019 period has been between 979 mm and 886 mm. An Automatic Weather Station (AWS) has been established on-site and has been collecting data since mid-2020. At the time of lodging application in August 2020 and through to May 2021, insufficient data had been collected to allow meaningful correlation with observations and records available from long-established nearby weather stations, variously referenced below.

Table 2-1 Regional mean monthly rainfall (Updated May 2021)

Location	J	F	M	A	M	J	J	A	S	O	N	D	Yr
Dunedin Airport	69	63	56	48	60	47	46	40	42	58	50	72	652
Musselburgh (Dunedin)	73	68	64	51	65	58	57	56	48	62	56	80	738

Source: NIWA, 2015. Data for the 30-year period 1981 - 2010

2.4.2 Temperature

Daily average temperatures across the year vary from 6.7 °C to 7.8 °C. Mean daily maximum and minimum temperatures (by month) are shown for Musselburgh in Table 2-2 below, which also shows the average number of frost days per month, as recorded over the thirty-year period from 1981-2020. It is anticipated that the site will be colder and will experience more ground frost days than Musselburgh, due to its higher and more distant location from the Pacific Ocean coastline.

Table 2-2 Mean monthly temperature and number of frost-days (Musselburgh)

Category	J	F	M	A	M	J	J	A	S	O	N	D	Yr
Max (°C)	18.9	18.6	17.3	15.3	12.7	10.6	10.0	11.2	13.2	14.7	16.1	17.3	14.6
Min (°C)	11.6	11.5	10.2	8.2	5.9	4.0	3.1	4.2	5.9	7.2	8.6	10.4	7.6
No. ground frost days	0	0	0.2	1.3	4.8	10.8	15.2	10.3	4.8	2.7	0.4	0	50.5

Source: NIWA, 2015. Data for the 30-year period 1981 – 2010

The frequency and intensity of ground frost occurrence will be estimated more accurately when further information becomes available from the on-site AWS (particularly 2021 winter data) and allows correlation with longer-term Musselburgh and Dunedin Airport climate records.

2.4.3 Wind

Monthly average wind speeds are between 12.1 km/h to 15.7 km/h.

Wind strength and directions measured at Dunedin Airport are strongly influenced by the topography of the Taieri Valley, with dominant wind directions being from the west-southwest and east-northeast.

In lieu of generating sufficient records from the site weather station, predicted wind patterns have been modelled for the site, as reported in Technical Report C (Air Quality Assessment). Although the wind rose generated for the site generally aligns with predominant west-southwest and east-northeast flows, the ridgeline location of the site causes predicted wind patterns to contain a slightly greater westerly component than those observed at the Airport.

2.3.12.4.4 Evapotranspiration

Although on average more rainfall occurs in summer months, soil moisture deficit occurs over the period from October to April in response to temperature and sunshine hours. During winter months there is little evapotranspiration.

2.42.5 Site Geology

Available geological maps (Bishop [1994], and Bishop and Turnbull [1996]) show the site to be underlain by the Henley Breccia Formation. Although not shown on the geological map (Figure 4), borehole investigations show the Henley Breccia to be overlain by up to 5 m of topsoil, colluvium, loess, and alluvium in gullies. Bedding dips of 10-15° were measured in the Henley Breccia. ~~Investigations have also encountered Taratu Formation deposits on hilltops in the south-western corner of the designation area.~~

A summary of the geology encountered during ground investigation is presented in Section 3.4.1; and discussed in detail in the Geotechnical Interpretive Report (GIR), (GHD, 2021a).

Figure 4 - Geology Map

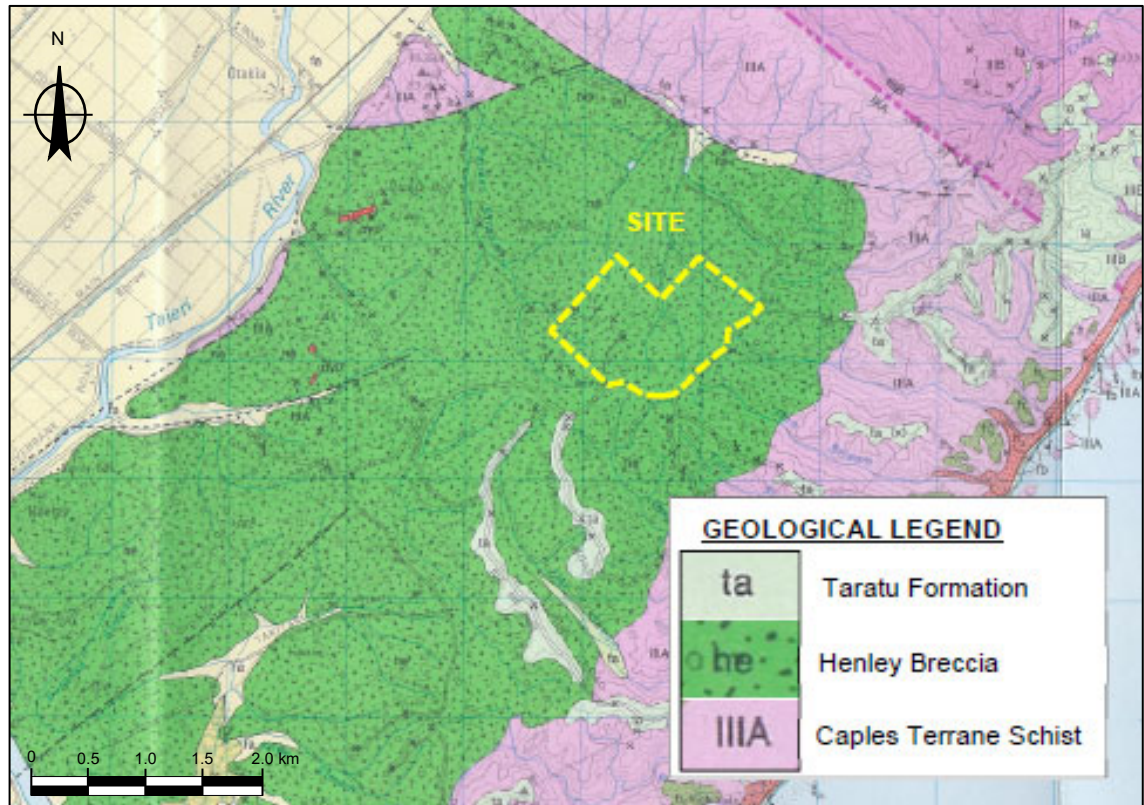

3. Landfill Concept Design

3.1 Guidelines

The landfill is designed to meet the requirements of:

New Zealand Government, 2011 (amendment) *Resource Management (National Environmental Standards for Air Quality) Regulations 2004*

Waste Management Institute New Zealand (WasteMINZ). 2018. *Technical Guidelines for Disposal to Land*

3.2 Design Objectives

The objectives of the landfill design have been developed in consultation with Council and are as follows:

- Capacity for the lifespan of the landfill to meet Council's current waste management strategy, whilst also allowing for:
 - Unexpected events which may increase waste volumes in the future
 - The potential to reduce the size of the landfill in response to any significant reduction in waste volumes
- Containment of waste and leachate appropriate for a Class 1 landfill.
- Avoid contamination of groundwater and downstream surface water.
- Avoid (or minimise) migration of landfill gas (LFG) from the site.
- Minimise amenity effects for surrounding rural-residential activities.
- Retain existing areas of [native](#) vegetation/habitats and archaeological values where practicable to do so. [As noted in section 1 of this report, design changes have also been made to avoid areas of wetland in the vicinity of the landfill site and to the extent practicable associated with the upgrade of McLaren Gully Road and Big Stone Road.](#)
- A free draining final landform where ponding of surface water is avoided through grading towards the perimeter swale drains.
- Stable slopes.
- Access for maintenance, rehabilitation or monitoring purposes.
- Economically viable refuse placement capacity through optimisation of the footprint and height of the resultant landform.
- A final landform suitable for future light stock grazing and shallow rooted planting.

The landfill [design incorporates a](#) staged construction [sequence](#) to minimise affected site areas, [improve construction-phase stability](#) and [to allow early and progressive stabilised/capped completion of final capping profiles](#).

3.3 Project Description

The project comprises the construction of a landfill with a capacity of approximately ~~6~~[3](#) million cubic metres ([gross capacity](#)) to provide for the safe disposal of municipal solid waste ([MSW](#)) for a period ~~in excess of~~ [approximately 40](#)~~34~~ years (~~up to 55 years based on expected waste generation rates~~). The landfill will be designed to accept municipal solid waste in accordance

with acceptance criteria for a Class 1 landfill described in Appendix D of the *WasteMINZ (2018) Technical Guideless for Disposal to Land*. The overall project will comprise:

- All works associated with the development of an operating landfill on the identified footprint area including:
 - Earthworks to construct the required shape
 - Construction of a low permeability lining system to prevent leachate seepage into the surrounding environment
 - Construction of a leachate collection system above the low permeability lining system
 - Stormwater control around the constructed landfill and other areas of the site with appropriate treatment and attenuation of stormwater before it leaves the site
 - A landfill gas (LFG) collection system to collect LFG from the placed waste
 - A leachate management system, including (leachate storage, tanker loading facilities and leachate treatment facilities)
- LFG treatment by an LFG plant
- Provision of water supplies for operational including firefighting (non-potable) and staff (potable) requirements
- Provision of overhead power cables capable of HV transmitting electricity generated by future LFG engines
- Construction and operation of a new landfill access road from McLaren Gully Road/Big Stone Road to the landfill operational area.
- Upgrade and sealing of McLaren Gully Road and Big Stone Road from State Highway 1 to the site entrance
- Heavy vehicle movement on-site to operate the landfill, including excavators and bulldozers
- Heavy vehicle movements to and from the site
- Other vehicle movements for staff, contractors and possibly visitors
- Operational infrastructure such as weighbridges and vehicle wheel wash
- Facilities for site staff, including on-site wastewater disposal
- Maintenance facilities for site plant and equipment
- Landscaping and tree planting to minimise the visual impact of the facility
- Environmental monitoring systems

The details of these works are described in subsequent sections of this report. Development of a landfill is essentially a [long-term](#) construction project. The landfill will be developed in stages, with one stage being filled with waste while the next stage is constructed.

3.4 Geotechnical Design

The geotechnical design for the landfill is detailed in the Geotechnical Interpretative Report (GIR), (GHD, [20210a](#)). The factual results of the geotechnical investigation along with published and Client supplied geotechnical data is provided in the Geotechnical Factual Report (GFR), [\(GHD, 2021b\)](#).

3.4.1 Summary of Encountered Geology

Topsoil

A layer of topsoil was encountered at depths of up to 0.25 m [below ground level \(bgl\)](#) across most of the site; this will be classed as unsuitable material and removed from the landfill footprint [and stored in long-term stockpile locations for potential re-use as daily cover or final cover](#).

Shallow Slope Instability Features

Debris was encountered in localised areas across the site during investigations and several small shallow slope instability features were noted around the site although not all were drilled or excavated. The debris associated with these features was generally encountered at the surface (occasionally with a thin veneer of topsoil) [and](#) extended to depths ranging between 0.4 m bgl to 2.7 m bgl.

Typically the debris comprised disturbed gravelly silt, silty sand, sand, silt and organic material such as tree roots and branches. Observations of the morphology of the features and composition of associated material and morphology suggests that these are shallow features associated with the loess with no obvious evidence of deeper-seated ground movement.

Slip debris will be classed as unsuitable material and removed from the landfill footprint and stored for daily or intermediate waste cover use.

Alluvium

Alluvium was encountered in the base of the gullies around the northern area of the site to depths of up to 2.7 m bgl. The alluvium typically comprised waterlogged sand, silt, and gravel in varying amounts.

Alluvial soils will be classed as unsuitable material and removed from the landfill footprint and stored for daily or intermediate waste cover use.

Loess

Loess was encountered across most of the site to depths between 1.25 m to 4.1 m bgl and typically comprised non-plastic to low plasticity silt, with varying amounts of clay, sand and fine gravel.

Laboratory testing loess samples from the site to investigate suitability as landfill liner or capping material. Completed laboratory testing of the loess indicates it can be compacted to achieve a permeability of 3×10^{-8} to 5×10^{-10} m/s, which is a relatively low permeability and desirable for a liner or capping. However, the loess is also potentially dispersive. This is an undesirable property for a landfill capping or liner material where long-term integrity is important.

However, loess materials can be made non-dispersive through stabilisation by the addition of lime or bentonite. Completed lab testing, [\(refer to Section 6.2 of the GIR \(GHD, 2021a\)\)](#), has shown the addition of 2.5% lime by weight results in a non-dispersive material and indicates that this type of material stabilisation may result in a material suitable for a landfill liner or capping layer.

Atterberg testing of the untreated loess indicates it plots on the A-Line of the Casagrande plasticity chart, [\(refer to Section 6.2 of the GFR \(GHD, 2021b\)\)](#), suggesting that it has some plastic behaviour. Completed Atterberg testing on lime stabilised loess samples indicate the material remains on the A-Line. Further testing during detail design is required to confirm the effect of stabilisation on the plasticity of compacted loess and its ability to self-anneal. If used as a part of a liner system or a capping layer non-plastic behaviour and development of cracks

would not be acceptable. The use of loess as a liner and capping material is discussed further in Section 3.10 of this report.

Henley Breccia

The Henley Breccia Formation encountered in exploratory holes comprised sandstone, siltstone, conglomerate, breccia with localised thin interbeds and lamination of organic mudstone/ lignite.

Assessed strengths were variable both within lithologies and vertically and ranged from extremely weak to very weak in completely to highly weathered material to moderately strong in unweathered sandstones and breccia.

Throughout the depth of Henley Breccia Formation few defects were logged in [the](#) boreholes. Logged defects were generally widely spaced bedding partings with occasional joints cross cutting bedding.

It is proposed to use excavated Henley Breccia as engineered fill beneath the base of the landfill to infill low areas and provide a base for the liner system.

3.4.2 Site Seismicity

As discussed in Section 2.2.3 of the GFR ([GHD, 2021b](#)), there are a number of identified faults within 100 km of the site. No faults are identified on the site in published data. In addition, no faults were identified on the site during the completed investigations for this project.

It should be noted that the faults described in Table 1 of the GFR ([GHD, 2021b](#)) are faults that are listed in the GNS Active Faults Database. However, the majority of those listed do not meet the definition of “Active” as defined by GNS Science (i.e. recurrence interval <2000 yrs). The closest active fault to the proposed landfill site, as defined in NZS 1170.5:2004, is the Alpine Fault, which is located 240 km to the northwest.

~~Whilst landfills are not specifically referenced in NZS 1170.5:-2004 (and 1170.5 Section 1.1 specifically excludes slopes), on the basis of leachate being classed as a hazardous substance, the landfill has been assumed to have an Importance Level (IL) of 3 (...containing hazardous materials capable of causing hazardous conditions that do not extend beyond the property boundaries) to give some guidance as to possible design lifetimes and resultant return periods. For a design working life of 50 or 100 years, IL3 structures are required to be designed to resist earthquake loadings with return periods of 1000 and 2500 years respectively. Whilst landfills are not specifically referenced in NZS 1170.5-2004 (and 1170.5 Section 1.1 specifically excludes slopes), the landfill has been assumed to have an Importance Level of 2 (IL2—normal structures and structures not in other importance levels) to give some guidance as to possible design lifetimes and resultant return periods. For a design working life of 50 or 100 years, IL2 structures are required to be designed to resist earthquake loadings with return periods of 500 and 1000 years respectively.~~

The site investigation results show the ground conditions at the site should be classified as subsoil site class ‘C’ (shallow soil), as per NZS 1170.5:2004.

~~For slope stability assessment under seismic load, the New Zealand Transport Agency Bridge Manual (NZBM) provides a method for determining a design ground acceleration, however, NZBM does not use design life and defines annual probability of exceedance (NZBM, Table 2.3). This table returns a design return period of 1/1000 years. Seismic coefficients for preliminary geotechnical design for slope stability have been calculated using NZBM. Using this methodology, the peak ground accelerations (PGA) derived for the site are 0.31 g for damage control limit state (DCLS) (equivalent to ultimate limit state (ULS)) and 0.08 g for service limit state (SLS) (¼ DCLS).~~

~~At detailed design stage, a site specific probabilistic seismic hazard assessment could be completed if seismic shaking is deemed a risk that cannot be mitigated through liner design and leachate management practices. Recent papers² by GNS on the Titri Fault and by Taylor-Silva on the Akatore Fault are consistent with the recurrence interval data already considered. On this basis we do not believe a site specific seismic hazard assessment is required for the site. For slope stability assessment under seismic load, the New Zealand Transport Agency Bridge Manual (NZBM) (NZTA, 2018) provides a method for determining a design ground acceleration, however, NZBM does not use design life and defines annual probability of exceedance (NZBM Table 2.2). This table returns a design return period of 1/500 years. Seismic coefficients for preliminary geotechnical design for slope stability have been calculated using NZBM. Using this methodology, the peak ground accelerations (PGA) derived for the site are 0.24 g for damage control limit state (DCLS) or ultimate limit state (ULS) and 0.06 g for service limit state (SLS) (¼ (25% of DCLS).~~

~~At the detailed design stage, a site specific probabilistic seismic hazard assessment should be completed.~~

3.5 Formation Stability

Construction of the landfill will require both cutting into the existing valley landform and filling to create the desired landform. Based on the preliminary earthworks plan, a number of cross sections have been generated to analyse engineered cut and fill slopes comprising cuts into natural soils and rocks and engineered fill from site won material. The following stability scenarios have been considered:

- Static Stability – Target Factor of Safety 1.5
- Seismic Ultimate Limit State (ULS earthquake loading) – Target Factor of Safety 1.0
- Seismic Serviceability Limit State (SLS earthquake loading) – Target Factor of Safety 1.0

Slope stability analyses provided in the GIR for the proposed cut and fill design slopes indicate appropriate slope stability for the proposed design (refer to GIR Section 7).

As discussed in Section 3.4.1 of this report, a number of existing shallow areas of instability features have been identified on the site associated mostly with loess material. These features will either be removed during the landform excavation or do not intercept the landfill or associated structures. These features can be investigated further and slope stability modelling and hazard and risk assessment carried out during the detailed design of the works.

3.6 Landfill Stability

The overall form and design of the landfill must ensure ~~the project is~~ stability during development, operational periods ~~and in closure~~. The landfill is located in the head of a gully such that the final landform ~~will be~~ buttressed against pre-existing hill ~~sites slopes to the northeast and southeast and by the existing central ridge of the gully to the southwest on three sides~~. The northern ~~end aspect and low end~~ of the landfill will ~~be supported by~~ have a 10-m high ~~toe~~ embankment constructed from engineered fill that will ~~buttress~~ buttress the otherwise ~~unsupported side of the landfill into the amphitheatre of the natural gully~~.

During development of the landfill, waste will be placed against this embankment at a stable slope. ~~While the specification of placement of waste in the landfill techniques~~ to ensure waste

² Investigation of past earthquakes on the Titri Fault, coastal Otago, New Zealand, DJ Barrel et al, GNS Science Report 2017/35 October 2020
Paleoseismology of the Akatore Fault, East Otago, B Taylor-Silva April 2017, Master Thesis University of Otago

stability during ~~site development~~ filling will be addressed during detailed design, the proposed filling sequence (Drawings C210 to C214) is a widely used methodology and provides a level of inherent stability as prior stages and sub stages provide buttress support to subsequent stages. Nonetheless, during detailed design consideration will also be given to the interface friction angle at the base of the landfill between the waste and liner to protect against ~~a base~~ slide failures or ~~a potential circular slip failures~~ through the base. This will partly depend on the ~~Engineered protection against these risks will be addressed as comprehensively as possible in the final liner system design selected for the site. This is also to be addressed during detailed design.~~

The overall stability of the landfill (stability of the bund with the full waste placement in the completed landfill) is presented in Section 7.6.1 of the GIR (GHD, 2021a). The landfill stability for the sections are presented in Tables 5 through 7 of the GIR (GHD, 2021a) and summarised below (Table 3-1). The calculated landfill stability values indicate the stability is appropriate. This issue requires further analysis and confirmation during detailed design.

Table 3-1 Landfill overall stability (Updated May 2021)

#	Condition	Required FoS	Minimum Calculated FoS
1	Static (permanent)	1.5	2.70
2	Short Term Static (elevated water levels within landfill)	1.3	1.7
3	Serviceability Limited State Seismic	1.0	1.96
4	Ultimate Limited State Seismic	1.0	1.0

3.7 Landfill Formation and Airspace

3.7.1 Landfill Footprint

The proposed landfill will occupy a portion of the designated site (approximately ~~44.5-18.6~~ ha of the 87 ha designated area). The landfill footprint and associated airspace development is summarised as follows:

- The airspace is sufficient for disposal of approximately 6-2.9 million cubic metres (equivalent to ~~5-2.4~~ million tonnes) of waste. Based on an assumed annual disposal rate of ~~9960,000~~ tonnes per year, the landfill has a design life of ~~55-40~~ years. It is recognised however, that uncertainty exists regarding the future annual regional waste generation rates and that Council will be working towards minimising waste as much as practicable. volumes that will be generated in the region and received at the landfill. This includes consideration of the need to allow for

Resilience in landfill capacity is necessary to protect against unpredictable future events such as flooding, earthquakes and as yet unforeseen major redevelopment projects, all of which could result in significant spikes in regional waste generation rates, needing to be disposed of. It is also recognised that the Council will be working towards minimising waste as much as practicable. As described in Section 3.9, the landfill will be developed in four major stages, which will provide some flexibility for responding to sudden changes in rates of waste generation. This allows future flexibility in landfill development and ability to respond to future events. For example, a significant reduction in annual waste disposal rates may mean that the Stages 1 and 2 are sufficient for waste disposal over many decades and it is not necessary to develop stages 3 through 5 for the foreseeable future. Alternatively, an unexpected future event may result in an increase in waste volumes and the landfill has the capacity to cater for this type of event.

- ~~Concerning a future reduction in annual waste volumes, the landfill is located in a gully system that is naturally bisected by a low central ridge. This ridge will be largely retained to segregate the landfill leachate collection systems into two halves — Stage 1 and 2, and Stage 3 through 5. The landfill liner drawing 51-12506381-01-C201 and 51-12506381-01-C204 show the retention of the natural ridge as a point of separation of Stages 2 and 3.~~
- The landfill has been located within the designation area to take advantage of ~~the~~ existing topography to the extent possible, minimising the amount of cut and fill necessary to form the base grade. Earthworks are however required to create planar surfaces for the placement of the landfill liner system.
- Development of the landfill design has been in consultation with the project team landscape architects. To the extent possible, the final cap profile has been developed to integrate with the surrounding landscape. The final surface profile is generally no more than 5 m above the adjacent ridge line formed by Big Stone Road. This will allow views of the landfill to be screened by trees.
- Development has also been in consultation with the project team ecologists. The footprint has been positioned to avoid areas within the designation identified as potential being of higher ecological value, including the western gullies. [In response to s92 questions the landfill design has been revised to avoid earthworks within wetlands within the designation area as much as possible.](#)
- As shown on [Drawing C102](#), the archaeological remnants of two buildings have been identified within the [site-designated landfill development](#) area. ~~Neither of the ~~The~~ remnants of one of these buildings will need to be removed as part of Stage 5 development. The remnants of the second building is located north of the area lie within areas~~ affected by the landfill development and [both sites](#) will be retained in line with ~~the~~ recommendations contained in the Archaeology Report ~~and incorporated into any future landfill visitor experience (see Archaeology Report).~~

3.7.2 Base Grades

The base grade for the landfill liner will generally follow the broad gully profile and be from 4% for the flatter base and up to 25% for the inclined liner faces. Excavation and filling will be required across most of the site to form the sub grade and/or remove compressible/problematic soils. Depth of excavation will be typically be between 2 m and 10 m and include removal of all loess and some of the underlying weathered and unweathered rock.

- All excavated soils (except for small amounts of unacceptable organic materials which will be stored and can be used as intermediate or daily cover) will then be used to form the landfill profile, liner, and capping. Low-grade soils will be used for daily cover. The loess (together with modification discussed in Section 3.4.1) is an important source of low permeability material for the landfill liner and cap construction and will be won and stored on site for later use wherever possible. Underlying weathered rock will be used for engineered fill.

~~Two soil stockpile areas will be constructed located on the eastern side of on the site, located as indicated in (Drawing C206).~~ These are temporary [storage facilities](#), as all [site](#)-won materials will eventually be consumed by [the](#) landfill development.

In some locations, engineered fill is required where the existing gullies are especially steep and need to be [flattened](#) by filling. The extent of the cut and fill to create the landfill base grade is shown on Drawing C209.

In addition, a 10 m high toe embankment will be constructed at the northern low point of the landfill to facilitate placement of and retention of waste and contain leachate (to be removed through pumping). The location of the toe bund is shown on Drawing C201.

Following excavation and filling, a 200 mm layer of selected soils will be placed where necessary to provide a construction base for the compacted clay layer of the landfill liner system.

The planar base of the landfill will be constructed with 4% longitudinal fall towards the leachate sump (i.e. to the northwest), but will also contain an asymmetrical ridge within the base plane to provide a cross-fall of 2% to the outer edges of the base, where perforated leachate collection drains will be positioned within the internal drainage layer.

This base-plane geometry has been designed to prolong the period in which clean stormwater runoff can be diverted away from initial filling activities in the Stage 1 filling program.

The overall slope of the inclined faces will be interrupted by the construction of benches of 10 m width at 10 m vertical elevation intervals to facilitate staged construction. The benches will also provide interim vehicle access routes and stormwater diversion, prior to their infilling. The construction bench infilling will result in the re-grading of sub-liner slopes with at least 510% crossfall to facilitate leachate flow through the continued drainage media profile and to prevent restrict leachate head build-up on the benches to less than 300 mm. The exact location of these benches will be determined at detailed design stage and therefore the design plans show the average inclined liner gradient of 20% (comprising a 25% grade for 10 m vertical height plus 10 m wide bench).

3.7.3 Final Fill Profile Landform

The final landfill capping landform is shown on Drawing C202.

The lower elevation batter slopes immediately above the 10 m high toe bund will be constructed at 1V:1H with provision for a multiple contour drain to be positioned up the slope to with 10 m wide benches every 10 m vertical increase in height provide a break in stormwater runoff flow-paths on this steeper capping surface and to provide long-term maintenance access. The benches will incorporate a longitudinal grade of 2% and a swale drain to direct surface water flow to the perimeter stormwater drain of the final landform. See Drawing C202.

The upper portion of the final cap that is more visible, will be constructed at 1V:20H. The cap will rise to the northwest from Big Stone Road to a maximum elevation of approximately 5 m above the road elevation, which will allow the top of the landfill to be effectively screened by tree planting on the Big Stone Road boundary. A small extent (a length of 150 m) of the final cap level will be up to 14 m above Big Stone Road where the road dips and fill in the landfill is required to achieve a grade in the perimeter swale drain. Engineered fill placed over this extent avoids potential for discharge from the landfill cap to flow to the southern catchment.

The entire final cap will shed water to the perimeter drainage swales that will continue to divert surface runoff to the stormwater attenuation pond at the northern base west of the landfill, which may be modified, but will be retained in closure, at the head of the naturally ephemeral gully stream.

Depending on the nature of placed waste and the degree of compaction applied during filling, landfill profiles are generally expected to continue to settle by up to 10% following the completion of filling activities. The largest landfill thickness (of 36.2 m) occurs close to the proposed ridgeline in the centre of the final landform, and at the top of the 1V:20H incline. In this area, more than three metres of settlement may be expected in closure, whereas proportionally less settlement would be expected towards the perimeter of the landfill, where lesser fill thicknesses occur.

This effect will be offset somewhat by the proposed filling sequence, where Stage 1 fill profiles (in the centre of the landfill) will consolidate and settle for several years prior to being filled-over by Stages 2 to 4. The final cap design presented in Drawing C202 is the assumed final profile

for the landfill and post operational settlement is likely and may require management to ensure surface draining is maintained. It is possible that an operator may choose to overfill the landfill to allow for long term settlement post-closure but this has not been assumed for the design presented in this report. But in overall terms, it may become operationally routine to fill the central and deepest portions of the landfill to final capping sub-grade levels that are initially elevated some metres above the final landform design surface.

3.8 Overall Volumes

Drawings C201 and C202 show the landfill liner and final landfill cap. Construction and infilling stages are shown sequentially in Drawings C210 to C214 and development stages.

Based on the placement of landfill construction material quantities summarised in Table 3-3 below, the estimated net landfill waste capacity (net of daily cover and excluding the landfill cap) is approximately 2.96 million m³ (equivalent to approximately 52.4 million tonnes of refuse). As discussed previously, at an assumed average waste disposal rate of 960,000 tonnes per year, the landfill void will be consumed in approximately 55-40 years.

The summary of the landfill void capacity is shown in Table 4.

Table 3-3 Landfill capacity (Updated May 2021)

Item	Unit	Quantity
Gross void	m ³	3,318,000
Final capping (1.55 m)	m ³	291,000
Drainage layer (0.3 m)	m ³	57,000
Intermediate cover (0.3 m)	m ³	27,000
Daily cover (0.15 m per 1.15 mm layer)	m ³	384,000
Net waste volume	m ³	2,944,000
Net waste tonnes (0.8 T/m ³)	T	2,356,000
Expected life (years)	yrs	39.3

In the capacity estimates presented in Table 3-3 above, the gross void is reduced by drainage, intermediate and final capping volumes, but not by the estimated volume of daily cover material. It is reasonably assumed that waste settlement and consolidation over the operational life of the landfill will compensate for the loss of volume from daily cover (with between 10% and 20% of additional void-space typically anticipated due to settlement). As discussed in Section 3.7.3, post closure settlement has not been included in the waste volume calculation. An operator may opt to over fill the landfill to allow for settlement post closure settlement. This would provide the potential for additional waste disposal at the site but has not been assumed in the landfill capacity calculations.

Estimated bulk earthworks volumes within the landfill construction zone are shown in Table 3-4. The table reveals an apparent deficit of up to 187,800,000 m³ of construction fill or cover soils, although this deficit is likely to be offset by:

- Site-won materials not meeting drainage aggregate specifications, requiring that drainage materials be imported
- The potential for waste soils received by the landfill to be utilised as daily cover
- Site-won material arising from the construction of site facility or stockpile platforms not included in the cut-fill calculations undertaken to date

However, the deficit occurs during the final stage of landfill development (Stage 5). Stage 5 may either not be constructed at all if the Council meets its waste minimisation targets; or constructed at some time in the distant future.

In the event that Stage 5 proceeds any shortfall at that time can be provided from a borrow area. Up to 800,000 m³ of soil may be required and Despite possible offsets, significant potential exists for there is considerable potential for additional borrow areas to be developed within the designation area. Detailed borrow area plans have not been developed at this time and resource consent for borrow areas is not being sought at this time.

Table 3-4 Bulk Earthworks volumes (Updated May 2021)

Item	Volume (m ³)
Total cut to sub-grade (0.8 m below liner)	933,000
Total fill to sub-grade	210,000
NET CUT TO CONSTRUCTION ACTIVITIES OR STOCKPILE	723,000
Sub-liner soils (0.2 m formation + 0.6 m compacted clay)	151,000
Drainage layer (possibly imported aggregate)	57,000
Intermediate cover (0.3 m)	27,000
Daily cover (0.15 m per 1.15 m layer)	384,000
Final capping (1.55 m)	291,000
TOTAL CONSTRUCTION FILL	910,000
NET MATERIAL DEFICIT	187,000

3.9 Landfill staging and operational life

The natural amphitheatre setting for the landfill lends itself to staged landfill development, which will occur in four stages (Stages 1 to 4).

Stage 1 will involve filling behind the toe buttress constructed at the northern base of the amphitheatre. Stages 2 to 4 will then progress in a clockwise fashion from northeast to west, filling over Stage 1 and buttressing into the surrounding gully sides around a toe buttress constructed at the northern base of the amphitheatre. The landfill will be developed in five formal stages (Stages 1 to 5) where Stages 1 and 2 will be in the north-eastern portion of the landfill footprint separated by the natural ridge from Stages 3, 4 and 5 in the south-western portion. Each stage will be the full width of the landfill (from Big Stone Road to the toe buttress). (Refer to Drawings C210 to C214).

The retention of the central ridge between Stages 1/2 and Stages 3/4/5 has a number of potential benefits:

- As discussed in Section 1.3, if future waste stream volumes reduce significantly, landfill development can be restricted to Stages 1 and 2.
- The risk of surface water from the southern area and associated gullies entering Stage 1 and 2 leachate collection systems during flood events is greatly reduced.

Each stage will be developed in turn sequentially in comprise several sub-stages. The approach to construction is provided in Section 7 of this report. The actual filling procedure will be developed during detailed design and will need to consider the temporary stability of waste placement. Accordingly, the procedure discussed in Section 7 may change, however the

requirement to cover waste with intermediate or final cover to minimise exposed waste will apply to any sequential filling arrangement.

Allowing for 13%³-Dismissing potential volume loss associated with daily cover and assuming a compacted waste density of 0.8 t/m³, the relationship of the void required for each tonne of waste is 1.25 m³. Assuming and a waste disposal rate of 960,000 tonnes per annum, Table 3-5 summarises the anticipated life of each landfill stage (excluding works to complete final capping and cover).

Table 3-5 Landfill development filling rates (Updated May 2021)

Stage	Available Net Void (m ³)	Waste tonnes ¹ (t)	Placement Period (Years)
1	642,000	513,500	8.6
2	524,000	419,000	7.0
3	857,000	685,900	11.4
4	921,000	736,700	12.3
TOTAL	2,944,000	2,355,100	39.3

¹ Tonnage calculated as a percentage in direct proportion of to volume and may vary where settlement allows additional waste placement.

3.10 Lining System

The purpose of a landfill lining system is to prevent leachate from entering underlying soils or groundwater and provide a containment system from which leachate can be collected and removed from the landfill. The Technical Guidelines for Disposal to Land (WasteMINZ 2018) describe two alternative minimum requirement lining systems, for Class 1 landfills, comprising from top to bottom:

- Type 1 lining system:
 - Leachate drainage material, with underlying cushion geotextile to protect geomembrane
 - Synthetic flexible membrane liner (FML), typically 1.5 mm high density polyethylene (HDPE) geomembrane
 - 600 mm compacted clay-cohesive soil with a coefficient of permeability ($k < < 1 \times 10^{-9}$ m/s).
- Type 2 lining system:
 - Leachate drainage material, with underlying cushion geotextile to protect ~~the~~ geomembrane
 - FML of 1.5 mm HDPE geomembrane
 - Geosynthetic clay liner (GCL) of minimum 5 mm thickness and with $k < 1 \times 10^{-11}$ m/s
 - 600 mm of compacted cohesive soil clay with a coefficient of permeability $k < < 1 \times 10^{-8}$ m/s
 - 300 mm of compacted cohesive soil with $k < 1 \times 10^{-9}$ m/s

These two lining systems are considered to be equivalent and meet the needs of a Class 1 landfill. Either option may be selected for use during detailed design. As discussed in Section 3.4.1, the on-site loess material may be able to be used as the 600 mm compacted clay liner with appropriate stabilisation through the addition of lime to address dispersivity characteristics while retaining plastic characteristic and the ability to self-anneal during deformation.

³ Based on 150 mm of daily cover for each 1.0 m depth of compacted waste

Completed permeability testing of compacted laboratory samples indicate a permeability of less than 1×10^{-8} m/s is likely to be achievable for the Type 2 system for non-stabilised loess. Further permeability testing during detailed design will be required to confirm this can be achieved and the impact of adding lime (to address dispersivity issues), and possibly bentonite, to the loess.

For the purposes of this report (and [supporting earthworks calculations and quantity estimates analysis completed elsewhere](#)) it has been assumed that a Type 2 lining system will be adopted. The proposed lining system is shown on Drawing C207.

All components of the lining system work together to contain leachate within the landfill and minimise leachate seepage. The combined system functions as follows:

- For there to be any leakage through a lining system there has to be a “head” (depth) of leachate on top of the system to drive downward seepage. An effective drainage system above the main containment layers drains the leachate away before a significant depth of leachate can form above the containment layers, thus limiting the potential for any leakage. Leachate depth will be maintained at less than 300 mm through the leachate collection system comprising drainage media and adequately spaced leachate collection pipework.
- The primary containment layer is the HDPE geomembrane. This is used in both the Type 1 and Type 2 liner systems. Individual sheets are welded together and all welds tested for potential leaks. The HDPE geomembrane is practically impermeable and strict quality control measures are used to ensure integrity during placement. However, for the purposes of assessing environmental effects a minimum level of leakage through the membrane is assumed based on the assumption that multiple “pinhole” imperfections could occur. For the Type 2 liner system this leakage is mitigated through intimate contact with the underlying GCL or for Type 1 by the compacted clay layer. The number of assumed imperfections is stated in the Hydrogeology Report (GHD, 2021c9).

For both Type 1 and Type 2 should there be a defect or damage in the HDPE, the underlying low permeability clay layer significantly restricts leakage that can occur. If the underlying layer includes a GCL (Type 2) then the bentonite (a very low permeability natural clay material in the GCL) swells when it becomes wet, filling the space between the HDPE and underlying 600 mm clay layer.

Where a GCL is not used (Type 1), the underlying clay layer will be assessed or otherwise modified to meet a permeability requirement of $< 1 \times 10^{-9}$ m/s.

- Any potential seepage has to flow through the GCL and/or 600 mm of compacted clay liner before it enters the underlying ground and is therefore reduced to the flow rate through that layer. Intimate contact in the area of the HDPE hole is critical to prevent leachate flowing laterally and increasing the surface area through (the GCL or clay layer) which the leachate may travel.

Calculations regarding potential seepage through the liner system are discussed in the Hydrogeology Report (GHD, 2021c9). Anticipated leakage rates vary as the landfill is developed but remain very small at all times. The maximum leakage rate near the end of the landfill life is expected to be [approximately in the order of 0.282](#) m³/year.

[As discussed in section 2.4.2 frost days are expected to occur at the site and will require that landfill practices incorporate frost management measures to protect landfill liner system components from frost heave. Measures include:](#)

- [Minimizing the area of exposed liner constructed head of waste placement in any substage](#)
- [Temporary cover for the exposed liner using soils or mulch](#)
- [Soil moisture management to minimize moisture levels/saturation of the liner system](#)

3.11 Leachate Collection

Leachate is the liquid produced through waste degradation and rainwater that percolates through the waste to the landfill liner, collecting dissolved and/or suspended matter from the waste as it passes through. A landfill is managed to minimise the volume of leachate that is produced. This is achieved by:

- Redirecting upslope surface water from entering the leachate collection system
- Minimising the size of the active filling area where waste is exposed to rainfall
- Covering areas with intermediate or final cover as soon as is practicable so that as much water as possible is shed into a stormwater collection system and minimising percolation of water through these layers into the underlying waste
- A stormwater collection system that enables monitoring of stormwater from areas of intermediate cover or final cover and ability to redirect that contaminated surface water to the leachate system if found to be contaminated.
- Providing well managed stormwater systems to separate all stormwater flow from areas where waste is placed and ensuring all site stormwater is diverted away from waste.

All stormwater that comes into contact with waste will be treated as leachate and will not be discharged to the stormwater system. Leachate generated within the landfill will flow to the leachate collection system at the base of the landfill from where it will be removed off site for treatment and disposal.

The leachate collection system will comprise:

- 300 mm thickness of drainage media overlying the ~~leachate containment system~~ landfill liner
- Perforated pipework ~~on near the base the the drainage base liner media~~, to ~~effectively collect drain~~ leachate ~~from the drainage media in and transfer to the~~ leachate sump ~~located~~ at the lowest point of the landfill liner. The depth of drainage aggregate materials will be locally thickened over the leachate drainage pipes at the edge of the landfill base to ensure separation from the waste where larger pipes are installed. For example, this will be achieved by forming a wedge of bench of additional aggregate at the base of Stage 1 side slopes.
- Leachate sump inside the landfill footprint at the base of the toe embankment containing high porosity media capable of attenuating leachate inflow arising from a rainfall event.
- Multiple inclined leachate pumps and risers will be laid from the edge of the embankment haul road down the internal face of the toe embankment and into in each of the leachate
sumps
- Leachate riser pipes will conveying leachate from the submersible leachate pumps to ~~the~~ leachate storage tanks
- Load out bay to fill leachate tanker trucks to transport the leachate to the DCC waste water treatment plant. The intention is to transition from trucking to a pipeline once leachate rates justify the change. This issue is discussed further in Section 5.1 and 5.4.

The leachate drainage plans and load out areas are shown on Drawings C401 through to C403.

3.12 Leachate Management System Design Requirements

The leachate collection system will be finalised during detailed design. The following are the design parameters that the leachate collection is required to meet;

- Under normal operating conditions the leachate head within the base of the landfill shall not exceed 300 mm ~~in normal operating conditions~~.
- The perforated leachate pipework ~~to shall~~ convey the predicted leachate flow from a nominal 10% Annual Exceedance Probability (AEP) rainfall event falling onto finished surfaces of Stage 1 (that will be predominantly finished with intermediate cover) and a partially completed landfill cell including varying proportions of open liner, uncovered waste and ~~capped~~ waste beneath daily cover. This flow to be accommodated in the voids within the leachate sump and ~~voids in the waste~~ drainage blanket at the base of the landfill cell.
- ~~Three-Four~~ leachate inclined pumps will be installed into each of the two leachate sump, where ~~two-three~~ pumps are capable of removing the accumulated leachate. The ~~third-fourth~~ pump is provided ~~for to allow for rotational~~ pump maintenance and to provide additional pump capacity in emergencies
- Leachate storage within the landfill and above ground storage tanks shall be sized to provide 48-hour storage capacity (plus additional spill-containment storage in the leachate storage tank bund for emergency situations)
- Leachate tanks ~~shall to be~~ above ground tanks, maintained under an agreed with programmed inspection ~~and/~~ maintenance regime
- The leachate storage tanks shall be housed in a spill containment bund capable of containing to provide emergency storage for the capacity of one leachate tank (should the tank fail)
- Leachate conveyance system ~~shall to be~~ constructed in polyethylene (PE) pipe with welded joint system

3.13 Final Capping

The primary purpose of the final cap on the landfill surface is primarily to shed precipitation to the surface water management system and thereby minimise seepage of water into the waste and the generation of leachate. In addition, the cap:

- Minimises the escape of LFG
- Provides a barrier between landfilled waste and any future users of the site
- Provides a suitable growing medium for appropriate cover vegetation

The final cover system is required to meet WasteMINZ 2018 Technical Guidelines for Disposal to Land for a Class 1 landfill. As a minimum standard, the proposed cap will follow the 'Enhanced Minimum' Final Cover Design and will include not less than 150 mm of topsoil, over not less than 6300 mm growth media layer, followed by at least 600 mm (and up to 1000 mm) of compacted cohesive soils (with permeability less than 1×10^{-7} m/s) ~~that overlays a minimum of 500 mm intermediate cover~~.

As discussed in Section 3.10 of this report, it has been assumed that the loess material will be used to construct the 600 mm low permeability layer within the capping system. Laboratory test data indicates a re-compacted permeability of between 3×10^{-8} m/s ~~to and~~ 5×10^{-10} m/s can be achieved using non-stabilised loess. However, for final capping placement it has been conservatively assumed that a field permeability of 5×10^{-8} m/s will be achieved.

It has also been assumed that lime stabilisation will be required for the loess to address the dispersive soil properties.

The limited growing media depth with in the final cap will be suitable for grass cover or shallow rooted vegetation only, which will require regular mowing or may support light stock grazing ~~or shallow rooted vegetation only~~.

3.14 Stormwater Control

3.14.1 Overall Stormwater Management

Stormwater management and control will be required during the construction, operation and closure phases of the landfill. Stormwater controls are shown on Drawings C102 [and](#) C301 [to](#) C311. The management and control [of stormwater is](#) required to mitigate adverse effects on water quality, [attenuate](#) runoff volumes [and rates](#), and [prevent](#) associated [contamination, erosion, scour or flooding](#) effects on the downstream receiving environment. [Key](#) issues and [their](#) associated control measures are [described](#) below.

Stormwater systems are required as part of the landfill operation to ensure that:

- Stormwater is diverted and separated from waste to avoid contamination – any stormwater that comes into contact with waste must be treated as leachate.
- To the extent practicable, erosion and transport of sediment from earthworks areas must be minimised. This is achieved through minimising exposed soil surfaces, installing cut-off drains to minimise flow over exposed earth surfaces, installing temporary measures where practicable to minimise the transport of sediment from earthworks areas, and stabilising these areas with vegetation or by other means as soon as practicable.
- Suitable conveyance systems (channels, pipes) are in place to carry the stormwater to suitable treatment devices to remove any sediment carried with the stormwater. These systems may comprise permanent systems (e.g. perimeter channels) or temporary systems as each stage is developed.
- [Adequate](#) treatment systems are in place to remove sediment from stormwater at all stages of development and operation of the landfill.

[In updating this report in May 2021, it has been decided that the detailed discussion on stormwater management during construction, operation and closure phases of the landfill will be provided in the Surface Water Report \(GHD, 2021c\).](#)

3.15 Subsoil Drainage and Groundwater

It is likely that groundwater seepages [may be](#) exposed [during](#) excavation to base grade levels. [However, the changes to the design have moved the toe of the landfill uphill from the areas of wetland at the northern edge of the site and consequently groundwater intercepts will be reduced.](#) Springs/ seepages remaining beneath a lining system can result in uplift pressures and [risks of localised failures](#) of the lining system, and therefore they must be controlled and drained away.

To control groundwater beneath the landfill, a network of subsoil drains will be constructed beneath the lining system to [alleviate](#) groundwater [pressures and provide sub-liner drainage protection](#) under all stages of the landfill development. [This includes a drain along the upslope toe of the bund. In the very unlikely event that leachate seeps through the liner system the subsoil drains also provide a collection system for any leachate seepage through the lining system. Groundwater drainage systems will be piped to a manhole and discharge structure at the external \(northern\) base -of the landfill toe embankment](#)

[Groundwater will either be discharged to the wetlands complex to the north of the site or used for non-potable purposes on site. To this end a pump will be included in the manhole. It should be noted that following construction of the Stage 1 base grade and toe bund groundwater seepage rates are anticipated to reduce from an initial peak of approximately 1 litre/second to a negligible flow as groundwater is drained from the geological materials in the base of the landfill.](#)

–In the highly unlikely event that monitoring of the collected groundwater indicates unacceptable quantities of leachate, the groundwater can be extracted and treated as leachate. The proposed subsoil drain system will comprise:

- The base grade of the landfill will include ground water drainage that will gravitate to the low end of the landfill where it can be monitored ~~and discharged to the attenuation basin.~~
- Any seeps in the upper slopes will be tapped with additional drainage that feeds to the base grade drainage.
- The base grade drainage pipe will be perforated HDPE pipe in straight alignments to facilitate water jetting if required.
- The collection manhole will also be fitted with a small submersible pump to extract water for storage at the non-potable water supply reservoir located at the facilities area. This water will be used for vehicle cleaning and other maintenance purposes.
- The groundwater collection manhole will be monitored for any leachate effects but will otherwise be designed to discharge groundwater to receiving wetland areas and upper Otokia Creek catchment, at the northern site boundary or pumped for storage and on-site use.
- The hydrogeology report suggests that although the sub-soil drainage may provide some initial lowering of groundwater levels within the localised shallow groundwater system, the effects will be relatively short-lived as groundwater levels are expected to fall below the elevation of the drains in response to the loss of recharge caused by progressive landfill liner construction. It is therefore anticipated that only minor volumes of groundwater will be abstracted through the subsoil drainage system over the life of the landfill, with the greatest rates of dewatering (maximum estimated discharge in the range of 87 m³/day (approximately 1 litre/second) occurring when dewatering systems are initially installed. The value has increased somewhat from a previously reported peak rate of 4 m³/day. This is largely due to the inclusion of a groundwater drain along the rear toe of the bund.

3.16 Perimeter Tree Planting

Landfill perimeter tree planting is proposed to provide visual screening along the exterior of the site and will also intercept dust generated from ~~the~~ site operations. A minimum 10 m wide vegetation buffer strip has been ~~provided proposed, to plant including~~ a mixture of exotic and indigenous tree species along the site boundary with Big Stone Road and along the north eastern ridge within the site.

All sections of the proposed vegetation screen can be planted at (or prior to) the commencement of the landfill development project. ~~The trees along Stages 4 and 5 (Stage B mitigation planning) will be planted on constructed fill which will not be in place until approximately year 29.~~

The planting will consist of double staggered rows of pine adjoining the site boundary combined with a mixture of Kanuka (*Kunzea ericoides*) and Totara (*Podocarpus totara*) within the site.

4. Landfill Gas Management

Landfill Gas (LFG) collection and destruction is required by the National Environmental Standards for Air Quality 2004 to be provided in a landfill has a capacity of more than 1,000,000 tonnes of waste and the system must be in operation before 200,000 tonnes of waste is placed. With the predicted waste stream of ~~9060,000 tonnes~~ per annum, the gas collection and flaring system ~~should be installed and would need to be operable operational early in the fourth within 2 years of commencement of waste disposal to meet these standards the landfill operation.~~

LFG management is described in the Landfill Gas Design Report (Appendix A to this Report). In summary, the proposed LFG management system will incorporate the following elements:

- The lining and capping systems described earlier in this report will retain LFG within the landfill and prevent off-site migration.
- An LFG collection system comprising a network of collection wells and pipework.
- A destruction system using flaring with the opportunity to generate electricity once LFG quantities are sufficient.
- Monitoring to confirm the effectiveness of the system, including LFG monitoring boreholes/wells outside the waste boundary and regular surface monitoring of methane emissions from the completed cap.
- Buildings and structures on-site (but outside the landfill footprint) will be designed and constructed to minimise the risk of LFG entry and accumulation.
- Subsurface services on-site will be designed and constructed in accordance with relevant standards in relation to LFG as applicable (e.g. AS/NZS 2381.1.1:2005).
- Appropriate work, health and safety procedures will be developed and implemented in relation to situations where workers/site users may be at risk of being exposed to LFG emissions.

Gas collection systems can be installed in a [variety](#) of different ways. [Most typically,](#) vertical [LFG wells are drilled into waste profiles](#) after placement of the final capping. [However, the revised geometry and filling sequence of the landfill may require that temporary horizontal or inclined landfill gas collection pipes be installed and connected to the gas extraction system, self development and](#) prior to the placement of [subsequent Landfill Stages and](#) the final cap. ~~temporary horizontal landfill gas extraction pipes can be installed and connected to the gas extraction system.~~ Other options for installation may be adopted.

The permanent wells will be pumped through near-surface and surface pipework to a gas destruction system that will be located at RL 125 on a terrace constructed on the north flank of the facilities area (see Drawing C5701). This location is 15 m lower than Big Stone Road and the flare will be largely screened from Big Stone Road and beyond by tree planting and the topography.

Gas destruction will be provided initially by flaring. The landfill operator may however install “gas to energy” at its’ discretion. This plant, if fitted, will be located at the prepared terrace where the proposed flare is located. The Landfill Gas Design Report (Appendix A) details the residual discharges from flared LFG.

5. Leachate Management

5.1 Leachate Quantities

Leachate is produced through decomposition of waste and where rainfall percolates through waste. Rates of generation are highest during operation where waste is being placed although this is mitigated as much as possible through careful management of the active landfill face. Flow rates through waste (including areas with daily cover) are further mitigated by absorption and evaporation. On completion of the landfill and application of the low permeability capping, leachate flows will be greatly attenuated such that the design flow will approach average annual percolation rates.

In designing leachate management devices in the landfill, allowance for the peak flow condition is required to prevent discharge of leachate to the environment.

By far the most dominant [contributing](#) response to a single rainfall event, is flow to the leachate collection system from the exposed landfill liner before waste is applied (and before attenuation of rainfall through the waste).

The percentage of rainfall and the reporting time for rainfall to reach the leachate collection system has been modelled using the Hydrologic Evaluation of Landfill Performance (HELP) software. The quantum of leachate produced annually is presented in the Hydrogeology Report ([December 2019 GHD, 20210c](#)).

There are five pathways for rainfall infiltration to [enter](#) the leachate collection system. [The](#) derived [reporting](#) time and [total rainfall as a percentage of annual rainfall, for precipitation to reach](#)ing the leachate collection system is tabled [below](#):-

Table 5-1 Rainfall infiltration pathways

Pathway	Reporting time	% infiltration
Flow from open liner (with drainage layer)	10 minutes	100 95%
Flow through 14 m depth of open waste	2 to 10 days	67%
Flow through 14 m depth of open waste with daily cover	2 to 10 days	34%
Flow through Intermediate cap	>7 days	29%
Flow through Final cap	>70 days	26%

Concept-level designs for the leachate collection system are shown on Drawings C401 to [C403](#). Leachate that reports to the leachate collection system, flows through pipework and drainage media to accumulate in the leachate sump at the [low point of cells 1/2 and 3/4 base of the toe embankment](#), where submersible pumps extract and deliver the leachate to above ground holding tanks.

Leachate will then be tankered off site until such time as a gravity pipeline will convey leachate to the council sewerage system connection in Brighton. This issue is discussed further in Section 5.4.

The in-cell leachate sumps provide storage for 10% AEP rain events through the voids within open graded aggregate that fill the sumps. Additional storage for 1% AEP weather events is provided in the waste.

The Stage 1 sump is separated from Stage 2 sump with a clay berm that extends up the interface of the base of the Stage 1 / 2 cells (refer to Drawing 51-12506381-01-C208). The same applies to the Stages 3 / 4. The berm overlies the continuously laid landfill liner so that complications in the construction of the landfill liner are avoided. The berm is constructed to 2.5 m above the nominal liner level at the sump and 1.0 m above the liner at the interface between stages 1 / 2 and stages 3 / 4 to provide the required in-waste leachate storage volume and During Stage 1 landfilling, separation between the leachate management system and surface water systems collecting runoff from as yet undeveloped portions of landfill foot-print will be maintained for the longest practicable duration. The management of stormwater during development of Stage 1 is discussed in more detail in the Surface Water Report (GHD 2021d). During Stage 1 stormwater will be treated within the landfill footprint and discharged to the wetland complex to the north of the landfill via a pipe through the toe bund.

When landfill development of Stage 1 of the landfill has been completed such that the landfill liner has extended to the level of the Stage 1 bench and top of the landfill toe embankment (some 10 m above the base of the landfill), the risk of leachate loss to surface water is practically eliminated as leachate would need to saturate the waste for a depth of 10 m before being able to over top the bund and is therefore unlikely. Consequently the critical storage of leachate within the landfill cells is assessed for Stages 1 and 3 only.

The critical leachate flows reporting to the leachate collection system infrastructure are summarised in the following table. The calculation sheets are provided in Hydrogeology Report (GHD, December 2021c).

The leachate storage return periods stated in Table 5-2 provide for 10% AEP where leachate discharge is contained in other devices, AEP of 1% is used where there are no secondary devices that would otherwise contain leachate discharge.

Table 5-2 Critical leachate storage volumes (Updated May 2021)

Infrastructure	Storm return period (AEP)	Unit	Required capacity	Design capacity
Leachate collection pipework	10% (TC 10 min)	L/s	151	150
Leachate sump storage	10% (TC 2 hr)	m ³	266	360
Emergency in waste storage (additional to the sump storage)	1% (TC 2 hr)	m ³	214	790
Total storage in landfill cell		m ³	481	1,030
Leachate storage tanks (Stages 1-4) (3 x 450 m ³ – 13 Dia x 5m high)	10% (2 days)	m ³	1,225	1350
Additional (to above tank storage) leachate storage in emergency bund for leachate tanks Based on bund base of 21 m wide x 55 m long and 1.5 m bund height	1% (2 days)	m ³	842	1,144

Notes and assumptions:

- ~~• ** The apparent discrepancy of the required storage over the actual storage in the leachate sump is not significant as the more than adequate additional capacity exists in the voids in the waste.~~
- Leachate collection pipework is -2 x 200 mm slotted HDPE @ 4% grade, providing a flow-rate of 75 litres per second per pipe
- Leachate drainage media will provides flow additional to pipe flow
- Porosity in leachate sump aggregate assumed as 30%
- Porosity in waste assumed as 30%
- Leachate pumps are assumed to be EPG Companies - SurePump™ Wheeled Sump Drainer Series 95 or similar with a 30 l/s flow capacity for each pump
- Leachate storage in the in-cell sump provides for 10% AEP event with the greater of 2 hours storage assuming pumps are not working, or the peak short storm duration flow (with pumps working).
- ~~• With combined cells (1 + 2 and 3 + 4 + 5) the in-cell leachate sump capacity is doubled as there are 2 sumps for each combined cell.~~

5.2 Leachate Quality

Leachate is generated from a Class 1 (municipal) landfill, due to the interaction of waste with infiltrating water and the release of liquids directly from the waste. Leachate can have varying quality, dependent upon the relative proportion of different waste types, landfill design, age of the landfill and local environmental setting. Typically, contaminant concentrations in leachate are highest when waste is exposed in an operating cell and decrease with closure and as the landfill ages. Decomposition of putrescible material and the transition of the landfill waste from an aerobic to anaerobic state, and the generation of organic acids over time also plays a key role in determining leachate quality, influencing microbial reactions, solubility and physiochemical reactions of leachate constituents.

Decomposition of putrescible waste and the leachate generating environment is often defined as occurring in three stages:

1. Aerobic degradation, generating heat and producing organic compounds and carbon dioxide.
2. Anaerobic degradation where large organic molecules are broken down into simple compounds such as hydrogen, ammonia, water, carbon dioxide and organic acids.
3. Methanogenic degradation where organic acids break down to form methane gas and other products.

Table 5-3 outlines an upper quartile for the highest leachate constituent concentrations of eight New Zealand landfills, outlined in the Centre for Advanced Engineering Landfill Guidelines (CAE, 2000). For the purpose of this report and associated studies, this has been assumed to be the likely typical composition of leachate generated by the Smooth Hill landfill.

Table 5-3: Upper quartile of the highest leachate constituent concentrations

Parameter	Upper Quartile Concentration – Class 1 Landfills (mg/L excluding pH) ¹
Aluminium	7.9
Ammoniacal Nitrogen	705
Arsenic	0.17

Boron	12.3
Cadmium	0.0063
Calcium	378
Chloride	1730
Chromium	0.17
Dissolved Reactive Phosphorus	3.4
Iron	183
Lead	0.13
Magnesium	193
Manganese	5.4
Nickel	0.19
Nitrate Nitrogen	0.86
pH	8.1 pH Units
Potassium	630
Silica	36
Sodium	1165
Sulphate	292
Total Kjeldahl Nitrogen	1220
Zinc	1.2
Total VOC	6.5
Total SVOC	4.4

¹ Upper quartile of the highest leachate concentrations recorded in eight consented municipal solid waste (MSW) Class 1 Landfills in New Zealand (CAA, 2000).

5.3 Leachate Collection

As described in Section 3.14, leachate generation will be minimised through diversion of surface waters, minimising exposed waste cells and early placement of intermediate and final cover to landfill waste. The base liner will ensure containment of leachate within the landfill and minimise any discharge of leachate to the groundwater system (see Hydrogeology Report).

The leachate collection system includes 300 mm of granular drainage media with perforated pipes placed at centres designed to limit leachate head to 300 mm above the line during normal operational conditions, to be placed on the landfill liner (see Drawing C207). However, as noted in Section 5.1, during low frequency/high intensity rainfall events the leachate level will be allowed to rise into the waste to allow for emergency short term storage. The drainage media will be protected with an overlying separation geotextile to limit soil fines that may clog the drainage media. Leachate drainage pipes will be extended to the edge of the landfill (up the landfill embankment bund to permit water jetting of the drainage collection pipework).

The leachate drainage pipes will be 200 mm ID smooth bore, slotted PE pipes designed to withstand the proposed waste load. The smooth bore pipes will extend the edge of the landfill [\(at the edge of the landfill embankment road\)](#) to [permit/facilitate](#) regular flushing of these pipes. At the minimum liner base grade of 4%, the capacity of each pipe is 75 l/s. Dual pipes will be installed at the toe of liner batters, however additional flow is available in the 300 mm deep drainage media that the pipes are laid in.

Leachate collected in the drainage pipework and media will report to a sump at the low end of the cell base where inclined leachate pipe risers will be installed to the surface of the landfill toe embankment. These risers will have inclined pumps, to pump to leachate holding tanks at the site facilities area.

Penetrations to the landfill liner system by leachate pipes will be avoided through the use of HDPE inclined pump riser pipes connected to the leachate collection system.

The leachate pump system will have multiple pump risers designed with one pump in redundancy. An emergency power supply will be installed at the facilities area to power the pumps should there be a fault in the overhead mains supply. [For this purpose and to power the site in the event of mains power loss, a 300kVA standalone diesel generator unit is proposed, which will provide sufficient capacity to support a full pumped load demand of up to 200kW from the leachate pumps. The 300kVA unit is anticipated to consume diesel at a rate of 66L/hour at 100% load, which has been factored into project related air quality and sustainability impact assessments for the project. The generator will be located on the lower facilities platform near the LFG plant.](#)

5.4 Leachate Storage and Management

Leachate Disposal

Leachate disposal from the landfill will be to the Dunedin City Waste Water Treatment Plant (WWTP). During the initial period of landfill development, leachate volumes will be relatively modest and leachate will be stored on site and transported via road tankers to the Green Island WWTP facility. At an appropriate point of site development, a pipeline will be constructed from the site to the nearest connection into the WWTP system at Brighton, approximately 7.5 km to the north east of the site. This is not part of the application and will be considered at a later date.

The average leachate volumes to be removed off site are summarised below in Table 5-4. The following table also provides a summary of the truck movement determination if trucking was continued through the life of the landfill. However, as mentioned above, the intent is to change to a pipeline. Based on the below values the most likely time to change is after completion of Stage 1. Based on assumed filling rates this will be [6 years approximately during the ninth year of landfill operation once truck numbers are in the order of 5 per day.](#)

Table 5-4 Average leachate removal by tanker (Updated May 2021)

Landfill Stage		1	2	3	4	Closure
Average annual leachate generation	m ³ /yr	26,697	29,499	41,337	46,555	38,581
Life of landfill stage	yr	8.6	7.0	11.4	12.3	30
Average leachate per day	m ³	73	81	113	128	106
Trucks per day (Assuming 20 m ³ tanker)	No.	4	5	6	7	6

[Note that tanker truck numbers will increase to the point that the landfill operator will decide that installation of a gravity leachate discharge \(to the DCC sewerage system\) is financially viable. This may be at the end of Stage 1 or during the early development of Stage 2 of the landfill.](#) **Leachate On-site Management**

While the leachate system is designed to limit the leachate head on the liner system to 300 mm or less, the landfill leachate sump will be designed to accommodate storage of 10% AEP storm flows and provide for emergency storage for a 10% AEP in the landfill and waste for a period of

4 hours to not exceed a 1.0 m head on the nominal landfill base liner. This period allows issues with power supplies or pumps to be repaired before the storage is exceeded.

Storage for the 1% AEP is provided in the leachate sump at the base of the landfill and leachate storage tanks at the facilities area. This combined storage approach is used, as it is not practical to pump the whole storm flow to the leachate storage tanks. Bunds separating partial cells in the landfill will have levels designed to contain the 100-year storm event.

Leachate storage at the tanks in the facilities area will accommodate a 24-hour 10% AEP storm with additional storage for the 1% AEP in the tank farm bund. See Drawing C403.

The critical leachate flow event is related to the temporary condition in the landfill development where the liner of a cell extension is installed and before waste is placed over this liner. Therefore there is no attenuation of the flow that waste would otherwise provide. As this condition exists at all stages of the landfill development – the storage tanks farm must be constructed in its entirety at commencement of the landfill operation.

The leachate storage tanks at the facilities area will be multiple 450 m³ Timbertanks™ or similar that are around 13 m in diameter and 5 m high. The tanks will be contained in a lined depression to accommodate 150% volume of a ruptured tank and provide additional storage for a 1% AEP rainfall event. Surface water from the bund will have a valve arrangement to allow manual discharge to the surface water system following confirmation that there is no leachate in that rainwater.

Once separately consented and constructed, the piped leachate drainage from the landfill to the Green Island WWTP via the existing Brighton network, will provide a flow rate for full discharge of the leachate from the tanks over the 24-hour period.

6. Ancillary Works

6.1 Operating Hours, Deliveries and Weighbridge

The landfill will be open for waste deliveries 7 days per week and up to 9.5 hours a day.

The proposed opening hours are as follows:

- Monday to Saturday 8.00 am - 5.30 pm
- Sunday 9.00 am - 5.30 pm
- Closed on Easter Friday, Christmas Day and New Years' Day, as well as the morning of Anzac Day (until 1pm)

The landfill operator may commence operations 1 hour before and up to 1.5 hours after the opening hours to prepare for waste delivery in the morning and to close off the works at the end of the day. Staff or contractors may be on-site outside these hours for required work, monitoring or maintenance.

The site will only receive deliveries from commercial operators – general public access will be excluded to the site although the Council are considering inclusion of a visitor centre to allow public viewing of the site and education opportunities. Any such centre will be located near the site entrance and securely separated from the site operations.

Anticipated truck numbers to access the site are set out in the Traffic Assessment Report (GHD, 2021e) and include the following during operational phases:

- Worker's vehicles
- Delivery of waste
- Leachate transport (initial phase of operation only).

During the period of construction vehicle numbers will increase due to construction materials deliveries and additional site workers.

For delivery of waste, the expected waste flow is 690,000 tonnes per annum. The estimated number of truck movements has been calculated and presented in Table 6-1. This data indicates an average number of truck movement per day in the order of 10 (assuming 80% capacity). This is an average number and allowing for daily variations during the year and leachate truck removal the total truck movements could be up to approximately 25 per day. Up to approximately 25 light vehicles may also travel to the site each day.

Table 6-1 Total truck numbers per annum (Updated May 2021)

Truck	Percentage of total deliveries	Capacity of each truck (t)	Total carted for all trucks @ 100% capacity (t)	Number of trucks if 100% capacity	Number of trucks if 80% capacity
6w	10%	10	2,654	265	332
8w	20%	15	7,964	530	664
semi	30%	22	17,522	796	995
T&T	40%	30	31,860	1,062	1,327
Totals			60,000	2,653	3,318

Trucks arriving at site will access the landfill through the proposed route from Big Stone Road. (see Drawings C702) The site will be fenced and a main gate at the access point will provide

security. Trucks will pass through the gate and be weighed at a weighbridge located inside the gate (see Drawing_C608 and C609 and C702).

Provision will be made for the weighbridge to be staffed with a kiosk installed between the incoming and outgoing weighbridges although other options and configurations for waste inspection may be utilised. This provides for manual/visual inspection of loads entering the site for compliance with the waste acceptance criteria for a Class 1 landfill described in Appendix D of the *WasteMINZ (2018) Technical Guideless for Disposal to Land*. If for any reason a truck load is rejected, a turning area is provided for the vehicle to leave the site. Following weighing, the truck will progress to the active landfill operational area for discharge via the internal access roads through the facilities area and across the landfill toe embankment. Once emptied to the landfill, trucks will pass through the wheel wash facility (see Drawing C701 and C702 for optional locations) to ensure any tracked waste or sediment is removed before departing from the site via the weighbridge and main gate.

6.2 Site Roading

6.2.1 Access Road

Description

Access from SH1 is via the existing McLaren Gully Road to the junction with Big Stone Road (a distance of approximately 4.3km) Traffic then turns right onto the existing Big Stone Road for 350m to a proposed landfill access road junction (see Drawings C611 to C612). A new access will be constructed from the junction to the site facilities and landfill – a distance of approximately 200m.

Upgrades Required to Existing Roads

An evaluation of anticipated traffic has been completed (see Transport Assessment Report, GHD 2020e) and based on the study upgrades to the existing SH1/McLaren Gully Road junction are proposed. These will include:

- Upgrade of the SH1/McLaren Gully Road junction with the inclusion of a south bound left turn lane (Drawing 601).
- Inclusion of “flag lighting” for the SH1 junction.

Widening and upgrade of McLaren Gully Road and Big Stone Road will be required up to the site access location. The legal roads and access to the weighbridge will be sealed.

The upgrade will not significantly affect stormwater volumes and the sealing of the road is likely to result in a reduction in sediment discharges in runoff. Design has therefore assumed that runoff will be managed via discharge to roadside channels similar to existing and that the same discharge points to watercourses will be retained so that the current drainage regime is not altered.

[The design has also considered the occurrence of wetlands along the existing road margins. To the extent practicable wetlands have been avoided during the road upgrade design process. This has included adjustment of the road centreline and grade as well as assumption that table drains will discharge into wetlands where they occur adjacent to the road.](#)

The concept level design for the road upgrades is shown on Drawings C602 through C612 and indicates the following earthworks are required:

- [Total cut volume up to 46,700 m³](#)
- [Total fill volumes up to 18,470 m³](#)
- [Cut slopes generally up to 4 m high with limited sections with higher cut slopes:](#)

- CH2820 – CH3020 (200m) cut slopes typically 5 to 6 but ~ 7m for 30m
- CH2380 – CH2540 (160m) cut slopes typically 5 to 6 m but ~7m for 30m.
- Embankments up to 7.5 m high
 - CH1300 - CH1380 (80 m) retaining structure up to 2.5 m high at toe of embankment
- ~~Total cut volume up to 47,400,000 m³~~
- ~~Total fill volumes up to 20,500,000 m³~~
- ~~Cut slopes up to 74 m high.~~
- ~~Embankments up to 7.56 m high~~

The adjustment of the road design to avoid wetlands has resulted in an increase in the size of some of the cuttings, as outlined above, compared to the previous design. This has potential additional visual impacts but it is considered this is an appropriate level of effect as it results from minimising the impact on wetlands. Loess road cuttings are typically cut at a steep angle to minimize erosion.

Internal Site Access

The landfill main entry will have a lockable gate located at the entrances. Waste trucks will continue through the access road, loads assessed and weighed at the weighbridge and then to the landfill past the landfill facilities areas as shown on Drawings C702. The wheel wash and weigh bridge will also be located in this area. Beyond this point the road will be unsealed. The leachate tanker trucks will enter the facilities yard to allow the trucks to fill with leachate before transporting the leachate to the DCC sewerage system for treatment at the Green Island WWTP

The design objective is for landfill access grades to not exceed 10% to be suitable for hauling full waste vehicles up-hill. The internal access roads will be constructed in a mix of cut and fill with slopes to be confirmed during detailed design. Fill embankments will be provided with fixed barriers to meet the requirements of the NZTA Safe System road safety approach.

Drainage for the new access road will be to roadside channels either side of the road in the location where it is in cut or at existing ground level and via sheet flow to the adjacent slope where the road is formed on a new embankment.

Tip Area Access and Perimeter Road

An access track will be constructed around the final landfill perimeter next to the perimeter swale drain. The purpose of the track is to provide 4-wheel drive access to the perimeter of the landfill for monitoring and maintenance purposes. The track will be a gravel road.

The perimeter track will be progressively constructed along with the perimeter swale drain as the landfill stages are developed. Stormwater from the perimeter access will be directed to the swale drain.

As discussed earlier in this report, waste delivery and construction traffic will enter the landfill via the main gate

Once on the landfill toe embankment, the waste delivery trucks will access the base of the landfill for ~~a bottom up~~ waste placement. ~~The existing ridge between Stages 2 and 3 is at the same level as the landfill toe embankment and this facilitates the construction of temporary access to the base of the landfill cells.~~

All landfill access roads will be unsealed.

Temporary aggregate access roads will be constructed on the landfill to provide passage of the waste delivery trucks. These temporary access roads will be amended regularly as the waste is placed and the level of the waste increased as the cell is progressively filled.

Surface run off from the access roads south of the intersection with the facilities area will discharge to the stormwater attenuation basin which will also provide a degree of treatment improving the quality stormwater discharges from the site. This attenuation basin also provides for the ability to manage a spill (should this occur) within the site and internal access roads closest to the landfill. Monitoring of water in the attenuation basin will be undertaken.

6.3 Site Facilities

Two main platforms will be created for the location of facilities: an upper area immediately to the north east of the landfill and west of the Big Stone Road access gate; and a lower platform to the north of the landfill (see Drawing C701 and C702).

6.3.1 LFG Flare, Possible Future Energy Generation and Leachate Storage

The LFG flare and any future energy generation facility will be located on the lower platform area and workshop area where the elevation is ~RL125 (Drawing C501, and C702).

Leachate storage tanks will be located on the upper platform (~RL135) to facilitate future gravity feed to the leachate load out platform and ultimately facilitate pumping to Brighton for discharge to the sewerage system at that location.

6.3.2 Site Office

An administration building will be provided for staff responsible for the operation of the landfill. It is anticipated that this would comprise the following or similar:

- Offices for landfill manager, construction manager, and others
- Offices for admin and accounts staff
- One office for laboratory, safety and compliance personnel
- Meeting room
- Lunchroom/kitchen
- Toilet and shower facilities.

This would be located in a single storey building as shown on Drawing C702. The precise location will be determined during detailed design. Parking will be provided adjacent to this building. As noted previously, this building and leachate storage will be located within the site security fence. If developed, public access/parking and a viewing platform/information boards will be provided east of this area and outside the security fence for public visitors. Access to the public area is from Big Stone Road.

6.3.3 Workshop and Staff Amenities

The layout of the workshop and facilities area is subject to detailed design. The following are indicative details to provide scale to the proposed facilities.

A workshop will be provided for plant and general maintenance. This may be a building of up to 20 m x 25 m with high access doors on the front to permit the large landfill plant to enter for maintenance and repair. Refuelling will occur at a dedicated location in the workshop compound where spill kits will be on hand. The workshop may have an associated store of equipment spares and essential landfill materials. This store would incorporate a toilet, shower, lockers and lunchroom.

A concreted equipment wash-down area with oil/sediment traps will be located near the workshop.

Water tanks will be provided to store non-potable water (from roofs or groundwater) for wheel wash, equipment cleaning and dust suppression requirements. Potable water for drinking and showers will be tankered in. Wastewater from the toilets and showers will discharge to the leachate collection storage tanks for removal off site and disposal to the DCC sewerage system.

Additional small buildings will also be provided in this general area to house small plant, equipment, etc.

6.3.4 Wheel Wash

A wheel wash will be provided on the main access road for cleaning the wheels of all vehicles leaving the site as shown on [Drawing C702](#). Beyond these points, the access road to the public roads will be sealed. The wheel wash will comprise a pressure under body spray wash with rumble bars through which the vehicles drive. Dirty water from the wheel wash will be captured in coarse sediment traps adjacent to the wheel wash and further treated in flocculation ponds before being recycled back to the wheel wash. Discharges of excess water from the wheel wash recycle system are expected to be minimal and only occur during periods of heavy rainfall. This water will flow into the landfill stormwater system and will pass through the landfill stormwater attenuation basin.

6.4 Water Supply

6.4.1 Potable Water

Potable water for use of the landfill staff will meet the requirements of G12 of the Building Code and will be from water tankered to the site during the initial years of operation. A water supply pipeline from Brighton will be installed at the same time as the leachate pipeline after about [96](#) years of site operation.

6.4.2 Non-Potable Water

Non-Potable Water Supply and Storage

The non-potable water will be collected from the workshop roof and extracted from the ground water control system ([if available](#)) discussed in Section 3.15 above will be stored in large capacity tanks at the Facilities Area during the initial years of operation. Water storage will also be provided to meet fire water supply requirements for the buildings at the facilities area in accordance with SNA PAS 4509:2008 (New Zealand Fire Service Firefighting Water Supplies Code of Practice) and the NZ Building code.

It is expected that after meeting fire supply requirements, daily demand for non-potable water may include the following.

Table 6-2 Non-potable water use

Use	Estimated volume
Dust suppression (four applications per day)	40 m ³
Wheel wash (Daily requirement to supplement losses)	5 m ³
Machinery wash/vehicle wash (intermittent requirement)	2 m ³
TOTAL daily non potable water use	47 m³

The proposed water storage of non-potable water is four days maximum supply requirement and 200 m³.

The annual catchment of the annual rainfall to the workshop building would produce approximately 300 m³ per year. A typical single rainfall event of 15 mm precipitation would produce approximately 7.5 m³ to flow to the tank. Although collection of roof water is beneficial, the supply volume is insufficient to meet the requirements for dust suppression over the summer season.

Groundwater collected from the landfill underdrains can also contribute to the water demands for the site. The Hydrogeology Report (GHD, 2021c9) estimates groundwater flows of up to 87 m³/day may be available produced from initial dewatering, although it is noted that these seepage rates are likely to reduce with time following site development.

Therefore, rainfall and groundwater will not reliably meet the water demands for the site, which and will need to be supplemented by tanker water deliveries during the initial years of operation. However, as described above, after around 96 years of operation a water supply pipeline will be installed from Brighton to meet the site requirements.

Firefighting Water

There are no pre-existing water sources on the site for fire water supply. The geology of the environs to the Smooth Hill landfill are such that the groundwater table is at the lower gully inverts and there is no continuous standing water in the lower gully and as such there is no reliable source for onsite fire water supply in addition to the supply discussed above.

First response firefighting water will be provided from on-site storage tanks and delivered to a fire with a site dedicated 10 m³ water tanker truck filled from a dedicated fire water supply tank of not less than 100 m³. Other non-potable water tanks will be available for fire use; however, use of those tanks for other uses may make the storage in those tanks as unreliable.

Should helicopter monsoon buckets be used; water could be taken from the Taieri River approximately 3.5 km from the Site. Road based tankers can obtain emergency fire supply water from the same source being 6 km from the landfill west via McLaren Gully Road, 1.5 km south on SH1 and a short section of Henley Road to where it abuts the Taieri River.

6.5 Dust Suppression

Dust management and suppression will be an important part of mitigating and avoiding on-site and off-site effects associated with the construction and operation of the site. A range of measures are described in the Air Quality Report (GHD, 2021f9) that will be implemented during construction and operation of the landfill to control dust emissions. As discussed above, it is noted that adequate water will need to be secured for this activity (estimated at up to 40 m³ per day).

6.6 Services

Electricity, telecoms, and data services are required at various locations on site. These will be arranged with the applicable service providers. Site telecommunications will use either mobile cell phone technology or a simplex radio system and would involve small antennae and repeaters mounted on the site amenities buildings. If generated, electricity will be exported from the site at 11 kV or 33 kV by pylons and wires to be installed from SH1, along McLaren Gully Road/Big Stone Road and through the main vehicle access to the landfill.

7. Landfill Construction, Operation and Closure

7.1 Landfill Construction Activities

The landfill operation is effectively a long-term construction project dominated by earthworks and stormwater management. The bulk of these activities are completed progressively with waste being received over the projected life of the landfill. Therefore, the activities can be broadly divided into:

- Initial construction activities
- Ongoing operational and stage development activities
- Closure and aftercare activities

This construction methodology sets out the considerations and possible construction method to be used. At the time of preparation of this methodology, detailed design was not completed and the procurement model for construction not confirmed. Additionally the construction period has not been determined.

Accordingly, this should be considered a possible construction methodology and subject to confirmation following detailed design and delivery methodology for the landfill.

7.1.1 Initial construction activities

Initial construction activities occur prior to the landfill accepting its first waste. It is anticipated that these activities will take place over at least two construction seasons prior to the landfill accepting waste, with a construction season generally being defined as the period from October to April/May the following year.

Initial construction activities will include:

- SH1 and McLaren Gully Road/Big Stone Road upgrades.
- Access road from public road entrance to the site including site entrance and security fencing.
- Initial site clearance
- Construction of main offices and associated facilities.
- Construction of leachate storage tanks and load out.
- Construction of attenuation basin and toe berm.
- Construction of permanent stormwater controls around the initial stage of landfill development.
- Construction of sediment control measures.
- Formation of base grades for sub stage of Stage 1 of landfill.
- Placement of low permeability liner system and leachate collection system for sub stage of Stage 1 of landfill.
- Construction of wheel wash and weighbridge.
- Perimeter screening plantings.

- The landfill gas system will not be installed until 200,000 tonnes of waste is placed in the landfill. This is expected to be around [3 to 42](#) years after commencement of the landfilling.

7.1.2 Operational activities

Operational activities include:

- Waste filling.
- Placement of daily cover and intermediate cover as required. Materials will be stockpiled in the area indicated on Drawing C206 or within the next sub stages of the landfill to minimise haul requirements.
- Stormwater management and maintenance works.
- Management of LFG and leachate systems.
- Environmental monitoring.
- Construction of the next landfill stage and other required construction work.

7.1.3 Closure and aftercare activities

Closure activities include placing the final capping layer on completion, establishing any final landscaping and removing any facilities and infrastructure that are not required during the aftercare period, or modifying such infrastructure for the aftercare period.

Aftercare activities include maintenance of the cap and stormwater systems, management and maintenance of the leachate and LFG systems and ongoing site and environmental monitoring.

The following sections describe these activities in further detail.

7.2 Initial construction activities

7.2.1 Earthworks

The ~~five~~ stages of the landfill are shown on [Drawing C210 to C21403](#). For completion, the landfill development requires earthworks involving [0.64-9](#) M m³ of cut and [0.90-85](#) M m³ of fill. Excess cut material will be consumed through the combined requirement for landfill liner ([0.1535](#) M m³), final cover soils ([0.2967](#) M m³) and daily cover ([0.3893](#) M m³). It is envisaged that waste soils disposed to the landfill can be used as daily cover. Based on these assumptions, the required fill exceeds the cut material by approximately [0.39](#) M m³. However, as discussed in Section 3.8, this deficit is projected to occur late in the project's life and opportunities exist to develop on site borrow areas if the deficit occurs. The exact requirement for borrow volume is subject to the quantity of waste soils deposited and cannot be accurately predetermined for the life of the project at this time therefore all numbers at this time are indicative only. ~~The Stage 1 earthworks will result in excess cut materials that will be required for further stages and will be stockpiled. This is discussed below.~~

Daily cover soils will be progressively excavated from future cut areas or stockpiled soils as the landfill develops.

The overall earthworks are typically limited to 5 m cut depth, although there will be deeper cuts on some [ridges](#). [Drawing C209 shows the necessary cut and fill ridges in Stage 3 and Stage 5 of up to 17 m](#). Loess soils will be excavated from beneath the landfill as they are ~~both~~ a viable source of landfill liner/cap and intermediate fill material. Excavated weathered breccia will be used for construction fill. Accordingly, the loess and breccia will be stored in separate stockpiles.

The breccia is generally sufficiently weak to be ripped and excavated although limited areas of blasting may be required.

7.2.2 Site Clearing

The landfill site is predominantly cleared forestry with replanted pine. Some native vegetation ~~and areas of wetland exist~~ in the ~~base of gullies but these are very limited in extent, the Stage 5 area and wetland species in the bottom of the gullies.~~

Clearing will only occur in the extent of the stage and associated sub stage that is under development. ~~For the Stage 1 works, this will include the sub Stage 1A liner footprint (plus allowance for the subsequent sub stage), the landfill toe embankment, the facilities area and the access road from Big Stone Road. This extent is shown on drawing 51-12506381-01-C803 by way of example of how sub stages will be developed within any given stage.~~

Cleared vegetation suitable for the purpose will be chipped and stockpiled for later use as erosion control mulch. Stumps and poor-quality organic material will be stockpiled clear of earthworks areas and water courses and allowed to decompose.

7.2.3 Topsoil Stripping

Topsoil will be required for placing on the final cap for establishment of vegetation. It is important that the topsoil is both removed from the base of the landfill and stored separately and appropriately in the stockpile area indicated on Drawing C206. Assuming a depth of 150 mm there could be up to ~~2765~~,000 m³ of topsoil that requires removal – although this will be progressively stripped, stockpiled, and re-used over the life of the landfill.

7.2.4 Unsuitables

Small quantities of organic rich alluvial deposits may be excavated from the base of some of the gullies. This material, along with the insitu loess, requires removal from beneath the landfill as it is not suitable as a base grade for the liner system. Materials will be stockpiled separately for possible future use as a growing layer on the cap or for disposal in the landfill as a daily cover.

7.2.5 Subliner

The base liner bulk cut will be to at least 800 mm below the design level of the liner. This allows for the removal of rock (where this exists) and the placement of a soil layer that provides a suitable substrate to the placement of the high specification compacted clay liner. The subliner will generally be non-cohesive site won soils compacted to 95% standard compaction.

7.2.6 Landfill Toe Embankment

The toe embankment is key to the stability of the landfill. Due to its height, it also provides protection from leachate loss should leachate levels rise in the landfill for any reason.

The toe embankment will be installed in its entirety during the Stage 1 works ~~to facilitate the construction of the stormwater attenuation basin and will, to~~ utilise cut material from Stage 1 that would otherwise be stockpiled and to provide vehicle access to the future stages of the landfill to permit future development.

The toe embankment will be constructed from breccia material excavated as part of the Stage 1 works. This will be placed and compacted as engineered fill to meet the requirements of the detailed structural design for the embankment. The foundation soils for the embankment will be removed where they are outside the specifications due to organic content or moisture content.

The liner will be placed over the upstream face of the embankment to ensure leachate containment if leachate levels temporarily rise in the landfill.

7.2.7 Liner System Construction

Compacted Clay Liner (CCL) Formation and Soil Modification

The following section provides an approach to liner placement based on the assumption that a Type 2 liner system will be utilised – as described in Section 3.10 of this report. This is intended as an indicative description of the liner placement process. Detailed design may opt for a variant to this approach and design.

The landfill liner can be installed to the extent that waste will be placed for the following 18 months. The landfill liner could then be extended annually with provision to continue filling 6 months past a 12 month design period (should the 12-month capacity be achieved at the start of winter). Installation of the landfill liner over winter cannot achieve the required quality and will not occur.

The liner formation will be constructed to provide a minimum transverse gradient of 2% and longitudinal gradient of 4% on the landfill base. These gradients will direct leachate to the sump where inline pumps will transfer the leachate to the leachate storage tanks.

The composite liner consists of (bottom to top) structural soil foundation (subliner as described above), compacted clay liner (CCL), flexible membrane liner (FML) textured both sides and a protective non-woven geotextile underlying the leachate collection system. A geosynthetic clay liner (GCL) will be placed under the FML on the base of the landfill (not side liners). The FML will be coloured white on the upper side to reduce thermal wrinkle development.

The composite liner will be overlaid with the leachate collection system. The interface friction values of the composite liner will undergo laboratory testing when the material suppliers are identified and accurate product information is obtained. As discussed in Section 3.6, laboratory friction test results will need to be reviewed during detail design with respect to the waste placement plan and liner/waste slope stability.

Suitably modified loess soils could be used for liner and capping development and will be set aside in stockpiles as part of the bulk earthworks. Initial testing reported in this document (Section 3.4.1) indicates that lime stabilisation of the loess material addresses dispersivity characteristics of the material. This issue will require further investigation and confirmation during detailed design. At this time it is assumed that any liner will conform to the requirements for a Class 1 landfill set out in the Technical Guidelines for Disposal to Land (WasteMINZ 2018).

Synthetic Liner Installation

Filter fabric, GCL and FML will be installed to the manufacturer's specifications progressively as the composite liner is constructed. GCL shall not be applied where there is risk or rainfall before the FML can be placed over the GCL.

Joints in the synthetic liners shall have laps and application of sealants in accordance with the manufacturer's specifications. The FML will be double seam welded and pressure tested prior to acceptance. Hot bead edge welding is only permitted where destructive test samples are taken from the FML liner.

In all instances, synthetic liner will be anchored in trenches at the top of the slope or intermediate benches as appropriate.

Leachate Collection System

Following acceptance of the composite landfill liner, the leachate collection system will be installed on the base of the landfill. The protective filter fabric will be applied to the FML prior to any work commencing on the leachate collection system.

All pipework will be polyethylene and joints butt welded and de-beaded internally. Electrofusion welding will only be accepted in exceptional circumstances. Perforated sections of the leachate pipework will be slot cut radially. All other leachate pipework rising to the edge of the landfill liner will be anchored and provided with removable caps for flushing purposes.

Drainage media will be applied over the prepared base liner as a single layer using low bearing pressure delivery vehicles and spreading equipment. Trafficking over the exposed synthetic liner will not be permitted.

The leachate drainage media will be protected from contamination with an overlay of a non-woven geofabric.

Leachate pump risers, pumps, delivery pipes, storage and loading facilities will be installed prior to placement of waste in the landfill. The leachate storage system and the load-out bay have containment systems installed to capture and retain any leachate spillage. This will be operational prior to placement of waste in the landfill.

Groundwater Management System

For much of the landfill site, groundwater within the underlying breccia is many metres below the base of the landfill. Seepage is however anticipated towards the landfill toe, and at the junction of the landfill base, ~~and the~~ sidewalls ~~and toe bund~~. Accordingly, groundwater drainage will be installed prior to the construction of the CCL.

The groundwater drainage will be designed to withstand the design loads and will be polyethylene with joints butt-welded and de-beaded internally. Electrofusion welding will only be accepted in exceptional circumstances. Perforated sections of the pipework will be slot cut radially. The perforated drainage pipework will be encased in open graded aggregates and the entire drain encased in filter fabric.

The loess soils are known to be easily erodible – therefore any drainage pipework will have filters applied to prevent soil particle loss to the drainage. The drainage pipework that extends under the landfill toe embankment will not be perforated and will not have filter material encasing the pipe bedding but will have anchor blocks to prevent longitudinal flow of water through the bedding. The groundwater evaluation has also assumed that a groundwater drain will extend along the full length of the upstream toe of the bund.

While significant amounts are not anticipated, any observed seepage in the side batters to the landfill will have secondary drainage pipework extending from the main groundwater drainage to the point of seepage. The specification for this secondary drainage will be the same as for the main groundwater drainage.

The groundwater drainage will report to an access manhole. Groundwater either be allowed to discharge to the wetland complex or pumped to storage for non-potable use on-site will be pumped from the manhole immediately before discharging to the attenuation basin. ~~The manhole also allows~~ flushing of the pipework and monitoring of the discharge. ~~This monitoring manhole may also have an electrical pump to divert ground water to tanks at the landfill facilities area for non-potable use as dust suppressant, wheel wash and equipment wash down.~~

7.2.8 Likely Machinery Requirements during the Construction Phases

Construction phases will be recurring every 2 to 5 years during the life of the landfill and are likely to require the following equipment (or similar):

- Vegetation chipper x 1
- Excavators x 4 (20 to 30 tonne)

- Scrapers x 2
- Moxy x 1
- Bulldozers (D6 equiv) x 2
- Padfoot roller x 1
- Grader x 1
- Vibrating smooth drum roller x 2
- Water cart
- Delivery trucks (come and go – only 1 stationed on site)

7.2.9 Stockpiles

The proposed stockpile locations ~~are~~ shown on Drawing C206. ~~Some excavated material may also be likely to~~ be mostly stored within the landfill footprint for re-use in the next phase of development. The stockpile areas will be used for longer term storage, as required. This may include:

- Surplus excavated materials until they are needed for landfill operations or final capping
- Low permeability loess material
- Topsoil
- Unsuitables

The stockpiles will have appropriate sediment control measures which may include the use of soils stabilisers, biodegradable cover or silt fences for the smaller stockpiles or sediment retention ponds and cut off drains for the larger stockpile areas. Stockpiles will be track rolled and trimmed to regular shapes and those not expected to be reworked within 1 month will have mulch or hydroseeding applied.

The western stockpiles will be no higher than 20 m. The eastern stockpile will be used for longer term storage of valuable materials such as loess and topsoil. The eastern stockpiles will be no higher than 5 m and will be grassed to reduce long term erosion and visual impact. A preliminary evaluation of the earthworks indicates storage requirements will peak at approximately 350,000 m³. Up to 70,000 m³ can be stored in the eastern stockpile and the western stockpile can store more than the projected 280,000 m³.

7.3 Operational Activities

7.3.1 Waste Composition

DCC is working towards diverting organic waste (whether collected by DCC or other private operators) away from landfill, but cannot guarantee all putrescible waste being diverted either before or during the operating life of the landfill. For this reason, DCC is seeking consent for The Landfill will be a Class 1 Landfill suitable to accept municipal solid waste, and hazardous materials that meet the leachability (TCLP) limits from Ministry for the Environment (MfE) 2004: Module 2: Hazardous Waste Guidelines – Class A.

Generally cleanfill and bulk green waste is not expected to be disposed at the landfill as these wastes are expected to be diverted from the waste stream and managed at facilities closer to Dunedin. It is however expected that some cleanfill or greenwaste will be comingled with other waste or may from time to time be deposited in the landfill. Contaminated soils that meet the acceptance criteria will be accepted. As previously described, daily cover will generally be won from excess earthworks spoil as the landfill base is progressively developed.

The waste composition for waste disposed to Green Island Landfill for the period 1 July 2017 to 30 June 2018 has been assumed to represent the waste characterisation for the Smooth Hill Landfill.

Waste will be co-mingled in the body of the landfill but is expected to include the following as outlined in Table 7-1:

Table 7-1 Waste Types

Waste Stream	Likely % of waste tonnage
Municipal Solid Waste General Waste	92%
Special/Hazardous Waste	8%

Waste minimisation ~~(for both putrescible (organic) waste and other non-putrescible streams)~~ is expected to occur ~~both before and during the operating life of Smooth Hill Landfill. This will include Council-led initiatives such as enhanced kerbside collection services and waste segregation at transfer stations, as well as non-Council initiatives driven by a broader response to increasing waste disposal levies and emissions trading scheme costs.~~

~~Over time, these initiatives will change both the quantity and composition of waste disposed at Smooth Hill landfill, preserving void space and reducing landfill gas generation. However, in the short term, using the Green Island composition provides a realistic view of future waste characteristics until such time as these initiatives are fully implemented. Over time, the proportion of organic waste may reduce, but using the Green Island composition gives a conservative view of the percentage of organic waste that needs to be accounted for when operating the facility.~~

~~off-site, with the Council responsible for determining the likely operations model for achieving waste minimisation (i.e. kerbside collection to transfer station—waste segregation and recycling and reuse—to landfill). As discussed above, at this time it has been assumed that Council will minimise compostable material from being disposed to the landfill to preserve void space and reduce landfill gas generation.~~

Special and hazardous wastes will require specific handling and deposition into the landfill in accordance with hazardous waste guidelines and as set out in the landfill management plan. Special waste is likely to include biosolids from DCC Waste Water Treatment Plants. ~~A review of Council’s long-term biosolids strategy is being undertaken in 2020/21 with a view to reduce biosolids to landfill long term, however the timing of any landfill diversion initiatives will not be known ahead of landfill consenting. Regardless the future management option chosen, the option of landfill disposal will need to remain available alongside other biosolids management strategies to ensure the resilience of Council’s management of biosolids. informing expenditure in the 2021 Long Term Plan.~~

7.3.2 Waste Placement

Incoming waste will be inspected and weighed at the weighbridge and trucked to the landfill tip area through the main landfill access road. At commencement of the landfilling with waste, the base of Stage 1 will be some 10 m below the level of the toe embankment crest. The natural land formation ~~on the western edge of the landfill between Stages 2 and 3~~ has ~~approximately the~~ same level as the toe bund. This will be utilised to create a temporary access to the base level of Stage 1. Access roads on the landfill will be amended as the waste level rises.

Initial layers of waste applied to the prepared liner and leachate collection system will be bagged waste or selected waste that has no protrusions that could penetrate the FML. This initial waste placement will be pushed out over the leachate blanket. Landfill machinery will not

be permitted to traffic over the leachate blanket unless there is at least 1.0 m thickness of waste. Compaction will not commence until the waste is greater than 2.0 m thick.

~~At commencement of the Stage 1 landfilling, a low bund will be installed at the interface of Stages 1 and 2 to provide support for the toe slope of the waste and to direct leachate to the leachate collection sump. This bund will also direct surface water from earthworks to the sediment retention pond and avoid entry to the leachate collection system.~~

Daily cover will be applied at the end of each day's waste placement.

Daily Cover

Landfill daily cover could be 150 mm of site won or imported soils. Acceptable imported soils may include contaminated soils that are non-odorous and meet the waste TCLP acceptance criteria for landfill waste, or construction and demolition waste. Daily cover will be placed at the end of each working day such that there are no uncovered areas of waste while the site is not operating. The operating cell of the landfill will be limited to around 300 m² to provide for not less than 1.0 m compacted depth of waste to be placed to avoid excessive percentage of cover soils to waste. Artificial daily covers are also an option that is available for consideration.

Intermediate Cover

Intermediate cover will be placed where waste will not be overlaid with fresh waste for more than 3 months. [This will include most of Stage 1 upon completion.](#) The cover soils will be low permeability loess stripped from subsequent landfill stages or stockpiles placed in compacted layers not less than 300 mm thick and with hydroseed applied. The cover shall be graded to the stormwater system where possible to allow runoff of uncontaminated water and reduction in leachate generation. Intermediate cover will be stripped before placement of fresh waste.

7.3.3 Likely Machinery Requirements during Operational Phase

In addition to the waste delivery trucks, the following machinery or similar are likely to be required for the operational phase of the project:

- Excavators x 2
- Bulldozer x 1
- Reuse compactor x 1
- Water cart x 1
- 6W truck x 1

7.4 Closure and Aftercare Activities

Prior to the end of the life of the landfill a Landfill Closure Plan will be prepared to detail the activities required for closure of the landfill and the aftercare period. In general terms, the following issues will be addressed.

The final capping system will be constructed progressively after filling in any area as the final waste level is reached. Cap construction will generally comprise:

- Excavating soils from the soil stockpiles and placing in layers on the landfill cap in accordance with the design
- Placing an upper topsoil and/or growth layer from materials stockpiled on site
- Constructing surface contour drains to manage stormwater falling on the landfill cap, including connections to the perimeter drainage systems

- Establishing vegetation

Equipment used for capping works will be similar to those identified above for construction phases, as described in Section 7.2.8.

On completion the stockpile sites will be graded to conform to the adjacent topography and revegetated and any stormwater systems disestablished.

The balance of the site will have permanent stormwater features finalised. This includes:

- Contoured swales on the landfill cap
- Perimeter swale
- Attenuation basin

All facilities not required during the landfill aftercare period will be removed.

Aftercare activities comprise:

- Ongoing operation and maintenance of the LFG extraction and treatment system
- Ongoing operation and maintenance of the leachate collection, treatment and disposal system
- Maintenance of the site stormwater systems
- Maintenance of the landfill cap, including filling any areas that may have been subject to differential settlement, repair of any surface erosion and maintenance of vegetation as required
- Maintenance of any remaining site infrastructure, including fences
- Ongoing environmental monitoring as required by consents
- Any reporting required by consents
- Responding to contingent events as set out in the Landfill Closure Plan.

8. Hazards and Contingent Events

During the construction/operational phase of the landfill a range of potential extreme events may occur that are outside the design scenarios. A number of different scenarios and potential response actions have been considered in the following section of the report.

8.1 Extreme Weather

Extreme weather events include very high rainfall episodes beyond the design criteria assumed in this report; very high wind events; and high snow fall events that prevent landfill operation.

For issues relating to extreme rainfall, in most cases the proposed stormwater treatment systems, leachate management systems and attenuation basin are designed to manage a 1% AEP event and limit potential environmental effects. Responses that may be required following extreme events include:

- Take immediate steps to prevent/minimise discharge of waste or leachate to the stormwater system and downstream receptors.
- Advise relevant authorities of any breach of any consent conditions.
- Investigate whether downstream effects have occurred and plan remedial actions.
- Undertake water analysis and prepare remedial action plan for approval of the consent authority.
- Treat or remove contaminated water as required by the consents or consent authority.
- Repair on-site infrastructure.

—In the event extreme snowfall event or extensive wind-blown damage may prevent access to the weighbridge or to the active waste cell for an extended period (more than 1 day). Actions that may be required include:

- Gaining access for site staff using 4WD vehicles as soon as possible.
- Once the site is accessed, reviewing all key stormwater, leachate management and landfill gas management components to ensure ongoing operation.
- Advise relevant authorities in regard to breach of any consent conditions.
- Take immediate steps to prevent/minimise discharge of waste or leachate to the environment.
- Coordinate the accumulation of waste at waste transfer station or re-direct waste to an appropriately classed disposal facility (i.e. Kate Valley Landfill or AB Lime Landfill).
- Provide portable weigh station on the emergency access or record waste deliveries based on estimation.
- Remove excess snow and or import aggregate to re-open access to the active waste cell.

8.2 Earthquake

Section 3.4 of this report provides an overview of the seismic risk associated with this location. This has been taken into account in the design of the landfill and will continue to be addressed through detailed design. An unlikely event larger than anticipated seismic event occurs it may result in:

- Instability of the permanent landfill face

- Instability of any internal working face
- Instability of the landfill toe bund
- Lateral displacement of the waste pile
- Possible excessive strains and/or rupture of the landfill lining system
- Tearing on the landfill capping
- Landslips elsewhere around the site and landfill access road (discussed further in Section 8.4)

Following a significant earthquake, the following actions should be undertaken:

- Inspect the landfill and surrounds for any visible sign of land damage, or damage to the lining system where observable.
- If identified, inform the relevant authorities and instigate an investigation program to determine the extent of any damage and necessary remedial actions.
- The lining system is of particular significance and damage may not be observable. Shallow waste slope failure could allow the waste to be removed to inspect the condition of the liner. If this is not possible, the groundwater collection system should be monitored weekly to identify any potential leakage of leachate from the waste through the liner.
- If there is a rupture of the composite liner – there is likely to be a direct report to the groundwater collection system and a quick response observed by monitoring. In such a case, the groundwater collection system is separated into four discrete systems and flows from the affected system can be re-directed to the leachate collection system should leachate content exceed acceptable levels.
- A rupture of the FML where the CCL is intact is likely to have a more moderate impact and the effects to the ground water collection system would be monitored and action taken as above where the effects of the discharge exceed acceptable levels as agreed with the Otago Regional Council.
- Tearing of the landfill capping may require the removal of expelled waste to the active cell and repair of the capping construction.
- Leachate breakout from the capping may occur through minor capping failures. Remedy may include excavation of chimneys into the waste to direct the surface discharge to the landfill and leachate collection system and repair of the landfill cap.

8.3 Leachate Discharge to the Environment from above Ground Systems

The event considered here is a “sudden” discharge. Any failure and leakage of the liner is considered a long-term event and would be identified through monitoring of the groundwater underdrain system and /or downstream groundwater monitoring wells.

A sudden leachate discharge to the environment could occur as the result of a number of events:

- Failure of the leachate rising main between the landfill and the storage tanks
- A leachate tank and bunding failure
- Spillage from a leachate tanker during filling
- Spillage from a tanker during filling or transport through the site

- In the longer term, rupture of the proposed pipeline between the site and Green island WWTP (not considered further here as will be the subject of a future resource consent application if needed)

The leachate riser pipes will be butt-welded PE and are resilient to movement and impact. The leachate storage tank farm is provided with emergency containment to accommodate a tank failure. The leachate load out bay is provided with storage of the tanker capacity to retain spillage should that occur.

~~Other than during the development of Stage 1, the landfill and some of the facilities area~~ gravitates to the stormwater system that reports all flows to the attenuation basin. Any leachate discharge to the environment from equipment failure would ultimately enter the attenuation basin. The low flow discharge pipework from this basin has stop valves to retain spillage (particularly in events not associated with a significant rainfall event). This arrangement allows stormwater to be monitored and either released to the environment if acceptable or held and re-directed to the leachate management system if not.

If a spillage occurred outside the catchment that drains to the attenuation basin (i.e. the landfill access road and public roads) it would involve a leachate tanker accident where typical environmental spill response mitigation associated with the spillage of any trucked hazardous substance would be need to be implemented.

8.4 Landslip

As discussed in Section 3 the site area is currently susceptible to shallow failures associated with the loess deposits that occur across the site. A number of existing landslips have been identified on site and will need to be investigated and addressed during the detailed design process. Reactivation of existing features or development of new landslips may occur on site – most likely in response to extreme weather events or a seismic event. In general, such events may not impact operations unless they damage site infrastructure or block access routes. Actions to be taken involve general and well understood civil engineering practices.

8.5 Attenuation basin dam failure

The attenuation basin is normally “dry” unless flows exceed the nominal base groundwater flow. ~~Water depth in the basin during operation is limited to 1.0 m depth of retained water up to a 10% AEP event.~~ The structure is designed to attenuate up to a 1% AEP through the piped system and excess to that flow will have safe passage over the stabilised overflow.

During a 1% AEP event, the attenuation basin will retain ~~5,000-3,300~~ m³ of water. The maximum height of the retaining structure ~~will be confirmed during detail design along with is 4.8 m (from crest to lowest downstream natural surface level).~~ ~~Consequences of failure and appropriate emergency measures, will need to be addressed during detail design.~~

8.6 Landfill Fire

Landfill fires potentially fall into three different categories:

- Surface waste fires
- Underground waste fires
- Fires in surrounding scrub/ trees

Underground landfill waste fires are typically very slow burning and by their underground nature are not a significant threat to the surrounding environs. However, they difficult to extinguish and emphasis must be placed on prevention. In regard to surface fires and fires in the surrounding scrub/tress the emphasis is on first response fire attendance and prohibition of ignition sources

and spark arrest to machinery will be set out on the landfill management plan. Provision of fire water supply is discussed in Section 6.4 above.

General procedures

- When discovered, personnel must advise site management or nominated chief warden immediately, no action is to be taken without notifying another person, unless in immediate danger.
- Information to be provided to the fire warden includes location of fire, type of fire, whether any person is trapped, injured or involved, any action taken so far.
- If possible – remove any machinery or equipment or shut down. Shut down any obvious fire hazards e.g. gas lines. Remove personnel from the area. Operators not to alight from plant or equipment unless safe to do so.
- Communications officer or chief warden representative will contact the emergency services if necessary, other personnel are not to unless instructed to prevent duplication and confusion of information.
- Control of the landfill is delegated to the most senior warden present who will direct evacuation if needed and liaise with emergency services.

Landfill fire management may include:

- Excavate out any waste on fire and smothering with inert soil material or similar. Use on site water cart and fire truck.
- Switch off power supply and LFG gas lines if there is subsequent risk.
- Site manager to direct plant operators for best approach to each individual incident.
- Plant and equipment should be moved to a safe distance away from the area.
- All fire water will be treated as leachate and managed accordingly.
- Personnel must not enter landfill area during a fire event unless instructed or accompanied by emergency services or onsite personnel with the relevant PPE (breathing apparatuses).

The on-site water tanker truck will be fitted with pressure pump and hoses to apply water until the Fire Service arrives to the site. It is important to not assume that the fire is extinguished.

Underground fires can occur deep within the waste through a combination of hot-spot development and pockets of LFG. While extinguishing these fires utilises a similar approach to that described above, access can be problematic and may require re-excavation of waste to achieve.

Fires in the surrounding brush/trees may ultimately result in a surface waste fire and damage to other infrastructure. A firebreak will be maintained around the site to limit the risk of a nearby brush fire spreading to the site.

9. Alternatives Considered

9.1 Landfill Designation Location

The Council commenced a search for a new landfill site to succeed the existing Green Island landfill in the late 1980s. The process and recommendations are documented in the Council report “A Future Landfill for Dunedin” (DCC April 1993). Thirty-two potential landfill sites were initially considered with respect to ecological, physical, social and economic factors. The initial selection process reduced the number of sites from 32 to 11. The 11 sites were then assessed against a range of criteria documented in the Beca Stevens 1992 report “Dunedin City Council Refuse Landfill Study – Site Selection Report” (Beca 1992A). Following this study and considerable consultation with a range of stakeholders including Tangata Whenua, consensus was reached by the Council that:

- In the immediate future the extension of Green island would be evaluated in detail; and
- Smooth Hill was the preferred future landfill site and would be investigated further to confirm the viability of that site.

Beca then completed an environmental impact assessment of the proposed Smooth Hill site in October 1992 (Beca, 1992B). The Beca report concluded that the site is technically suitable for a landfill with a capacity of approximately 55 years at filling rates estimated at that time. On the strength of the Beca (1992B) report; Council resolved to proceed with negotiations to purchase the Smooth Hill property and appropriate designation of the Smooth Hill site as a landfill site. These processes were completed over the following year, and the designation remains in effect.

Since that time, Green Island has continued to be Dunedin’s primary municipal solid waste landfill operation. However, current resource consents for the operation expire in 2023 and while the potential exists to extend the consents for a limited period, the Council decided to resume investigation and enabling of the Smooth Hill landfill option as part of the wider Waste Futures 2023 Project (that develops a comprehensive waste management and diverted material system for Dunedin).

In 2018 and 2019 the Council facilitated initial review of the Smooth Hill site followed by a feasibility assessment including: landfill filling plans; financial models; and landfill feasibility in terms of engineering, economics, environment, social and cultural aspects. The findings are summarised in the Stantec Report “DCC Waste Futures 2023 – Landfill Feasibility Workstream” (Stantec Feb 2019).

The Stantec feasibility report concluded that Smooth Hill has the capacity to accommodate current waste quantities to 2063 and beyond and further investigation did not identify any barriers to development – effectively confirming the 1992 study findings.

Based on these confirmatory findings Council approved proceeding to apply for resource consents for Smooth Hill and completing associated studies, including this design report.

Therefore, the Council have been through an extensive process of site selection in the early 1990s with wide ranging consultation with respect to the selection of the Smooth Hill site – concluding in the site being designated as a future landfill location. The recent 2019 work has confirmed that the Smooth Hill site remains a viable and the preferred location for a Class 1 landfill to replace the Green Island landfill.

9.2 Landfill Size and Footprint

The designation area is significantly larger than required for the landfill (i.e. 87 ha compared to a landfill footprint of approximately [18.644-5](#) ha) and allows some flexibility in landfill location as

well as co-siting of appurtenant facilities and structures. As discussed in Section 2 of this report, the topography of the site is a natural amphitheatre and the landfill has been sited to take advantage of the natural landform to the extent possible.

During the design process [and the subsequent design iterations described in Section 1 of this report](#), technical input from a range of experts has been used to help guide the design process and minimize environmental and social effects to the extent possible. Adjustments made to the landfill footprint and final form based on this input include:

- Avoidance of the “Western Gully” by the landfill footprint and appurtenant facilities. Initial ecologically studies identified this area as having higher ecological values (Drawing C102 for location of gully).
- Restricting the final landfill cap elevation to no more than 5 m above the adjacent landform to allow screening by tree planting.
- [Adjustment of the landfill footprint adjacent to Big Stone Road to allow for appropriate landscape plantings to screen the landfill from road users and adjacent properties.](#)
- [Further revision and adjustment of the landfill footprint in 2021 to avoid wetlands located in the gullies to the north and west of the current landfill footprint.](#)

The 2019 Stantec report targeted a landfill waste volume of 6,000,000 m³ for the landfill. A similar landfill waste volume [was initially targeted for this design. However, as described in Section 1, subsequent revisions to the design have resulted in a smaller landfill capacity.](#) Current Dunedin annual waste disposal rates are [anticipated to be 690,000 tonnes per year](#). If these rates are maintained the landfill has a life of approximately [4055](#) years. However, uncertainty exists over future rates of disposal. Issues include:

- The Council is looking to divert waste to recycling where possible, as well as promote waste minimisation. This is likely to result in a long-term reduction in landfill waste per head of population.
- This may be offset to some extent by population growth in the Dunedin area. Furthermore, the landfill may accept waste from other districts, increasing the annual rate of waste disposal.
- Significant region wide unexpected events can result in spikes in waste disposal rates.

Given the uncertainty regarding future requirements, the landfill has been developed to allow future adaption. As discussed in Section 1.3 of this report, a key adaptive approach is that the landfill [development can slowed down or sped up depending on demand, be developed in two distinct phases. If waste volumes reduce significantly, Stage 1 and 2 of the landfill may be sufficient for many decades and development of Stages 3 through 5 can be delayed long into the future.](#)

10. Limitations

This report: has been prepared by GHD for Dunedin City Council and may only be used and relied on by Dunedin City Council for the purpose agreed between GHD and the Dunedin City Council as set out in Section 1 of this report.

GHD otherwise disclaims responsibility to any person other than the Dunedin City Council and Council officers, consultants, the hearings panel and submitters associated with the resource consent and notice of requirement process for the Smooth Hill Landfill Project arising in connection with this report. GHD also excludes implied warranties and conditions, to the extent legally permissible.

The services undertaken by GHD in connection with preparing this report were limited to those specifically detailed in the report and are subject to the scope limitations set out in the report.

The opinions, conclusions and any recommendations in this report are based on conditions encountered and information reviewed at the date of preparation of the report. GHD has no responsibility or obligation to update this report to account for events or changes occurring subsequent to the date that the report was prepared.

The opinions, conclusions and any recommendations in this report are based on assumptions made by GHD described in this report. GHD disclaims liability arising from any of the assumptions being incorrect.

GHD has prepared this report on the basis of information provided by Dunedin City Council and others who provided information to GHD (including Government authorities)], which GHD has not independently verified or checked beyond the agreed scope of work. GHD does not accept liability in connection with such unverified information, including errors and omissions in the report which were caused by errors or omissions in that information.

The opinions, conclusions and any recommendations in this report are based on information obtained from, and testing undertaken at or in connection with, specific sample points. Site conditions at other parts of the site may be different from the site conditions found at the specific sample points.

Investigations undertaken in respect of this report are constrained by the particular site conditions, such as the location of vegetation and topography. As a result, not all relevant site features and conditions may have been identified in this report.

Site conditions (including the presence of hazardous substances and/or site contamination) may change after the date of this Report. GHD does not accept responsibility arising from, or in connection with, any change to the site conditions. GHD is also not responsible for updating this report if the site conditions change.

11. References

[\(References have been updated\)](#)

- Bischof, D.G. 1994, *Geology of the Milton Area. Scale 1:50 000, Geological Map 9*, Institute of Geological & Nuclear Sciences
- GHD, 2021a, *Smooth Hill Landfill Consenting - Geotechnical Interpretive Report (GIR)*
Project reference 12506381
- GHD, 2021b, *Smooth Hill Landfill Consenting - Geotechnical Factual Report (GFR)*
Project reference 12506381
- GHD, 2021c, *Smooth Hill Landfill Consenting – Hydrogeology Report*
Project reference 12506381
- GHD, 2021d, *Smooth Hill Landfill Consenting – Surface Water Report*
Project reference 12506381
- GHD, 2021e, *Smooth Hill Landfill Consenting – Transport Assessment Report*
Project reference 12506381
- GHD, 2021f, *Smooth Hill Landfill Consenting - Air Quality Report* Project reference 12506381
- Macara, G.R. 2015, *The climate and weather of Otago, National Institute of Water and Atmospheric Research (NIWA) Science and Technology Series 67*
- Ministry for the Environment, 2020, *National Policy Statement for Freshwater Management (Freshwater NPS)*, 3 September 2020.
- New Zealand Government, 2011 (amendment), *Resource Management (National Environmental Standards for Air Quality) Regulations 2004*
- New Zealand Transport Agency, 2013, *Bridge Manual SP/M/022 – Third edition (Amendment 3. Effective from October 2018)*
- Standards Australia/ Standards New Zealand, 2005, *AS/NZS 2381.1:2005 Electrical equipment for explosive atmospheres – Selection, installation and maintenance – general requirements*
- Standards New Zealand, 2004, *NZS 1170.5:2004 Structural Design Actions - Part 5: Earthquake design actions - New Zealand*
- Waste Management Institute New Zealand (Waste MINZ), 2018, *Technical Guidelines for Disposal to Land.*

Appendices

Appendix A – Landfill Gas Assessment and Concept Landfill Gas Management Measures

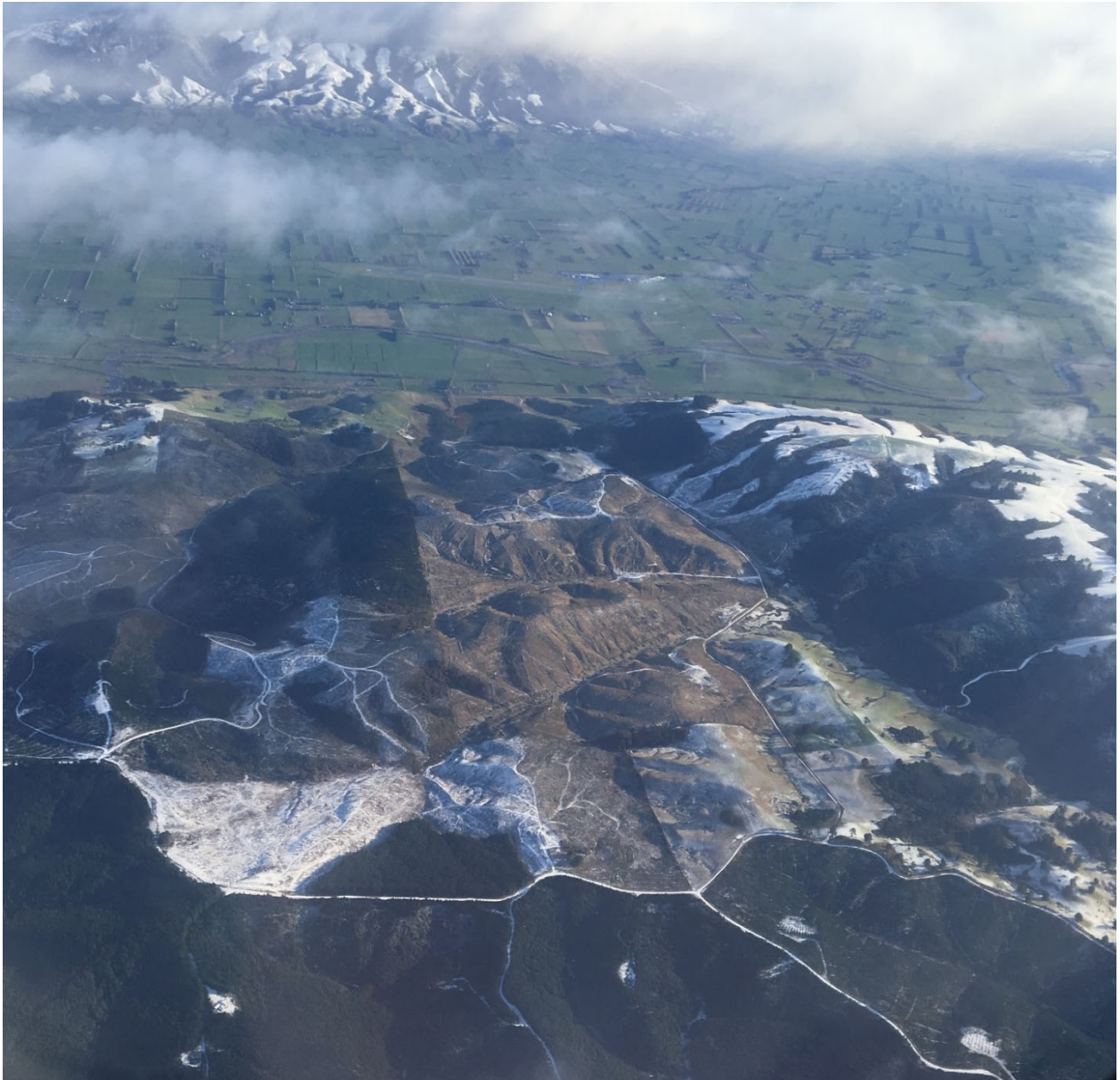

Dunedin City Council

Waste Futures - Smooth Hill Landfill

Landfill Concept Design Report

Appendix A - Landfill Gas Assessment and Concept Landfill
Gas Management Measures



[\(Updated May 2021\)](#) August 2020

Table of contents

1.	Introduction	1
1.1	Purpose of this report.....	1
1.2	Scope of works.....	1
1.3	Assumptions	1
1.4	Introduction to landfill gas	3
1.5	What is LFG?	3
1.6	LFG legislation.....	3
1.7	How is LFG typically assessed and managed?	3
2.	Proposed landfill site	5
2.1	Existing Environment	5
2.2	Landfill Overview	5
3.	Landfill gas emission model	7
3.1	Overview.....	7
3.2	Model outputs	7
4.	Preliminary landfill gas risk assessment (LFGRA).....	9
4.1	Overview	9
4.2	Source, pathways and receptors	9
4.3	Conceptual site models	11
4.4	Sensitivity of receptors	11
4.5	Potential impacts upon receptors	12
4.6	Key risks	12
4.7	Summary.....	12
5.	Regulatory documents and guidelines	14
5.1	Overview.....	14
5.2	The National Environmental Standards for Air Quality (Air Quality NES) Regulations 2004	14
5.3	WasteMINZ (2018) Technical Guidelines for Disposal to Land	16
5.4	Climate Change Response Act 2002	16
5.5	Ambient Air Quality Guidelines 2002 Update	16
5.6	International guidance.....	17
6.	Suggested LFG management measures.....	18
7.	Concept design of active LFG collection and treatment/destruction system	20
7.1	Overview.....	20

7.2	Design goals	20
7.3	Concept design	21
7.4	Key elements of system	21
7.5	Key assumptions for active LFG collection and treatment/destruction system	22
8.	Concept design of perimeter LFG monitoring bore network	23
8.1	Overview	23
8.2	Design goals	23
8.3	Concept design	24
8.4	BPEM bore network.....	25
8.5	Preliminary LFG monitoring bore network.....	25
8.6	Key assumptions for perimeter LFG monitoring bore network	26
9.	Reliance.....	27
10.	Limitations	28

Table index

Table 7-1	Design goals for proposed LFG collection and treatment/destruction system	20
Table 8-1	Design goals for proposed perimeter LFG monitoring bore network.....	24
Table 8-2	BPEM recommended LFG monitoring bore spacing for fissure or fracture flow-dominated permeable strata.....	25

Figure index

Figure 3-1	LFG emission model outputs.....	7
Figure 4-1	Relative sensitivities of identified receptors.....	12

Appendices

- Appendix A – Landfill gas model parameters, assumptions and justifications table
- Appendix B – Landfill gas model and calculations
- Appendix C – Conceptual Site Models
- Appendix D – Concept design drawings of LFG collection and treatment/destruction system

1. Introduction

1.1 Purpose of this report

The purpose of this report is to document the assessment of Landfill Gas (LFG) related impacts and appropriate LFG management measures for the proposed Smooth Hill Landfill (the Landfill). This report is an appendix to the GHD (2021~~0~~a) *Landfill Concept Design Report* (the Design Report) and should be read in conjunction with that report for information on the background to the project and the site setting amongst other relevant matters. [As noted in the Concept Design Report, an earlier version of this report was submitted as part of the application documents for resource consents with both the Otago Regional Council and the Dunedin City Council. In response to s92 questions from both authorities this report has been updated to reflect changes to the landfill design and s92 questions.](#)

1.2 Scope of works

GHD undertook the following scope of works for the Landfill as part of this report:

- Reviewed relevant background information, including relevant legislation and guidance
- Developed a parameters, assumptions and justifications table for a LFG emissions model
- Developed a LFG emissions model based on the parameters adopted
- Developed Conceptual Site Models (CSMs)
- Completed a preliminary LFG Risk Assessment (RA)
- [Identified potentially appropriate LFG management measures](#)
- [Review of s92 requests on initial LFG management system design](#)
- [Prepared-Updated](#) concept designs and supporting basis for an active LFG collection, treatment and destruction system, and perimeter monitoring bore network
- Prepared a report (this report) to document the works completed

1.3 Assumptions

During the preparation of this report, GHD has made a number of assumptions as identified through the text of this report and its appendices. These assumptions include (but are not limited to) the following:

- The assumptions adopted for the LFG emission model are adequate to produce a reasonable LFG emissions output model scenario for the purposes of this assessment.
- The assessment of LFG related risks is a subjective process and that one individual's tolerance for risk may be quite different to another individuals. The preliminary LFGRA completed as part of this report was completed by GHD personnel experienced in LFG management. Therefore, it is based on GHD's tolerance to the identified risks. This may be different to DCC (or other parties) tolerance to the same risks.
- The assessment of LFG related risks is only valid for the circumstances prevailing at the time of assessment.
- The concept designs proposed for the LFG system and the bore network as part of this assessment are to be considered as indicative only. The future contractors would provide more refined designs prior to construction or an alternative design and construction method that results in similar outcomes.

- GHD considers that the guidelines and information that have been adopted in this report in relation to assessing and managing LFG at the site were appropriate for that purpose.
- Where timeframes are discussed in this report, these timeframes are based on landfilling waste at the rate of ~~90~~ 60,000 t/annum and commencing in 202~~8~~2. The actual date waste deposition commences may be several years later. However, for the purpose of this report 202~~2~~8 has been used as a base date for modelling and reference purposes.

4.42. Introduction to landfill gas

4.52.1 What is LFG?

LFG is a complex mixture of different gases produced by the degradation of biodegradable waste materials deposited within landfill sites. The emission rate and chemical composition of LFG varies depending on many factors including waste type, time, moisture content, temperature, etc. During the anaerobic phase, when decomposition of biodegradable waste materials occurs in the absence of oxygen, methane and carbon dioxide are the major constituents of the LFG generated (although numerous other gases may also be present at low concentrations).

The timescale for the evolution of significant quantities of LFG typically varies from three to twelve months following waste deposition, and can continue for well over 30 years following the termination of waste landfilling activities.

LFG can cause health, safety, amenity and environmental impacts due to the gases it contains. Under certain conditions, LFG can:

- Be flammable and explosive
- Present an asphyxiation (suffocation) hazard
- Be toxic to humans, flora and fauna
- Be odorous
- Be corrosive
- Contribute to greenhouse gas emissions
- Contribute to photochemical smog

Due to its potentially hazardous nature, LFG must be appropriately assessed and managed at landfill sites.

4.62.2 LFG legislation

Under the National Environmental Standards for Air Quality (Air Quality NES) Regulations 2004, a Class 1 landfill, such as the Smooth Hill landfill, requires control and flaring of LFG where the landfill has a total potential capacity of not less than 1 million tonnes and contains not less than 200,000 tonnes of waste (refer to Section 6.2 for more details). The Smooth Hill landfill exceeds this criteria and the LFG system is required to be installed and operational [before when](#) 200,000 tonnes of waste is deposited in the landfill.

4.72.3 How is LFG typically assessed and managed?

The typical approach to assessing the significance of LFG related risks at a landfill site is to:

- Identify potential physical hazards that may be associated with LFG emitted from the landfill site.
- Review relevant site information in relation to LFG.
- Estimate potential future rates of LFG emissions from the landfill site.
- Develop CSMs for potential LFG emissions from the landfill site.
- Prepare an assessment of LFG related risks.

Following the completion of the tasks above, potentially appropriate LFG management measures for the site are identified.

GHD has adopted the approach above for the site. Further information on these tasks (as relevant to the site) is provided in the following sections.

In terms of potential impacts of combusted LFG on nearby receptors this issue has been addressed in the Air Quality Assessment report (GHD 2021¹⁰).

2.3. Proposed landfill site

2.43.1 Existing Environment

Section 2 of the GHD (2020a) *Landfill Concept Design Report* (the Design Report) for the landfill provides an overview of the existing site environment including the site geology. Of relevance to this report is any potential sources of ground gas within the existing environment – either natural or man-made. The site geology is summarised in the Design Report with a more detailed discussion provided in the Geotechnical Factual Report and Geotechnical Interpretive Report (GHD 2020b & GHD 2020c). The site’s geology is summarised as follows:

- The site consists of a series of relatively steep, generally dry, gullies that drain towards the north. The lower reaches of some gullies are infilled with relatively recent alluvial deposits that contain significant amounts of organic material. These deposits have the potential to generate gas. However, it should be noted that all such deposits will be removed from beneath the landfill and appurtenant structures during site development. Excavated materials are likely to be used as intermediate or daily cover during waste placement in the landfill. [Furthermore, the revised landfill design now avoids areas of wetland which are anticipated to contain much of the organic matter.](#)
- The site is underlain by the Henley Breccia formation, which comprises predominantly sandstone, siltstone, conglomerate, breccia with localised thin interbeds and laminations of organic mudstone / lignite. The latter has the potential for gas generation. However, it comprises a small percentage of the overall rock mass. Furthermore, permeability testing (GHD 2020b) indicates the Henley Breccia generally has a very low permeability and the likelihood of gas movement through this formation would be low. In addition, the Henley Breccia is overlain by several metres of low permeability loess.

2.23.2 Landfill Overview

As identified in the Design Report, the proposed landfill site will have a capacity of approximately ~~6.2.93~~ million cubic metres (equivalent of ~~2.3445~~ million tonnes) of waste and will be designed to provide for the safe disposal of municipal solid waste and an average of 15% hazardous waste for a period in excess of ~~395~~ years.

Key LFG aspects of this site will include:

- Construction of a low permeability lining system to prevent leachate seepage into the surrounding environment.
- Construction of a leachate collection system above the low permeability lining system.
- Stormwater control around the constructed landfill and ultimate treatment of stormwater before it leaves the site.
- A leachate management system, including (leachate storage, tanker loading facilities and ultimately a pipeline to convey leachate to the municipal wastewater treatment plant).
- A LFG collection system (including pipes and wells) to collect LFG from the landfilled waste within two years of commencement of landfilling.
- A perimeter environmental monitoring network including wells for landfill gas monitoring
- LFG treatment and destruction by a LFG plant.
- At some time in the future a LFG energy plant may be installed at the site. However, this is not part of the current work scope.

The Design Report provides an overview of the landfill construction methodology and operation including a summary of the anticipated waste types and tonnages in Sections 3 and 7. This includes a description of how the landfill will be constructed and how waste will be placed in the landfill during operations. In general the landfill will be a Class 1 landfill suitable for accepting Municipal Solid Waste and hazardous materials that meet the leachability (TCLP) limits from MfE 2004: Module 2: Hazardous Waste Guidelines. Class A contaminated soils that meet this limit will be accepted. It is possible that green waste will be predominantly diverted from the waste stream as part of the domestic waste collection process. However, at this time this has not been confirmed. Furthermore, some amount of green waste will remain in the waste stream even with diversion.

3.4. Landfill gas emission model

3.14.1 Overview

In order to develop an understanding of the potential magnitude of LFG emission rates at the site over time, GHD developed a LFG emission model for a landfilling period of 3955 years, which is consistent with the total design capacity of the site (see Section 2 of the Design report).

The model used for this exercise was the USEPA's (2005) Landfill Gas Emissions Model (LandGEM) Version 3.02. This model was adopted as it is the most commonly used LFG emission model in New Zealand, according to the Ministry for the Environment (2001) A Guide for the Management of Closing and Closed Landfills in New Zealand.

A modelling parameters, assumptions and justifications table (refer to Appendix A) was developed to document the relevant parameters, assumptions and justifications that were adopted for the model. The modelling output is provided in Appendix B and summarised in the following sub-sections.

3.24.2 Model outputs

The estimated LFG emission rates for the model are shown on Figure 4-1 below. Noting that the LandGem model presents the LFG emission rate outputs as m³/LFG/year, GHD converted these rates into m³/LFG/h in this report for consistency with typical industry practice (refer to Appendix B).

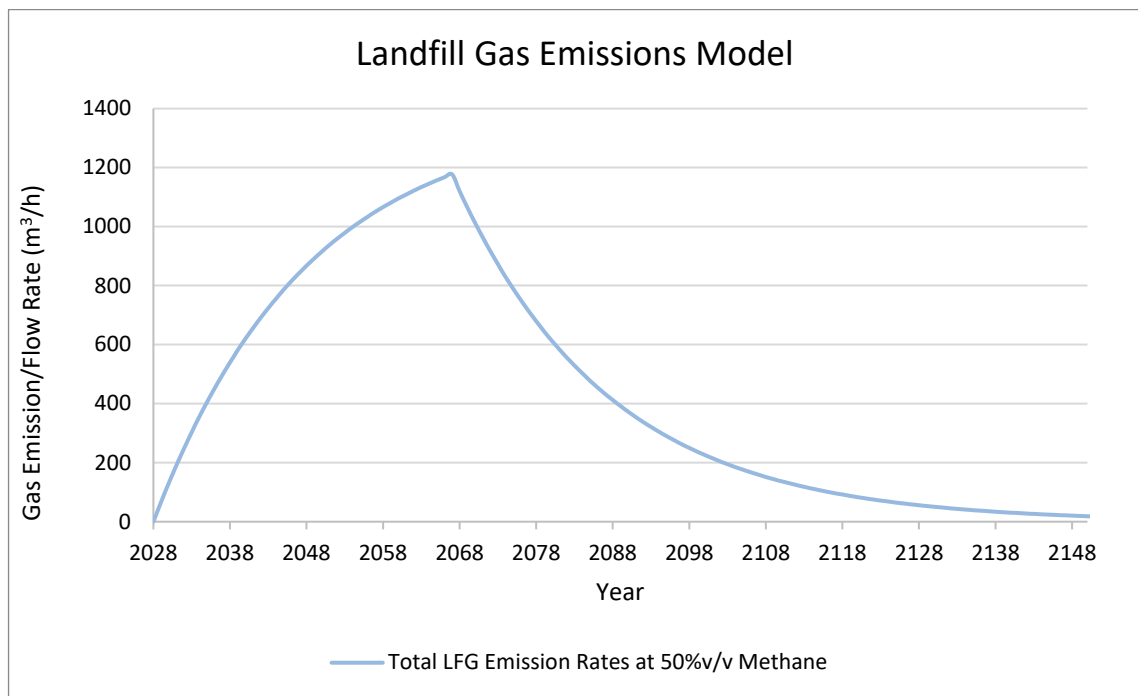

Figure 4-1 LFG emission model outputs (Updated May 2021)

Figure 4-1 shows the following:

- The proposed landfill is expected to start generating LFG in 2028 and will continue to do so for many years after landfilling of waste has ceased in 2066.
- The LFG emission rate at the proposed site will peak in 2067 at 1,177 m³/LFG/h and will steadily decrease every year post 2067.

- The LFG emission rate will be greater than 250 m³/LFG/h (i.e. moderate to large generation rates¹) between 203326 and 20972118 (6593 years).
- The LFG generation rates will be greater than 100 m³/LFG/h at 50% v/v methane (i.e. theoretically sufficient to operate a flare according to the EPA VIC (2015)) from 203024 to 21372116 (87114 years).

Based on the magnitude and longevity of the estimated emission rates, it is considered that active² LFG management using flares and/or engines will likely be required at the site for many decades to appropriately manage the LFG emitted.

¹ According to EPA Victoria (Australia) (2015) *BPEM, Siting, design, operation and rehabilitation of landfills*, Section 6.7.1 on page 35

² i.e. under vacuum

4.5. Preliminary landfill gas risk assessment (LFGRA)

4.15.1 Overview

GHD undertook a preliminary evaluation of the risks associated with LFG at the site using a source, pathway, receptor approach. The purpose of this task was to assist with understanding potential LFG related risks at the site and what LFG management measures may be appropriate.

It is noted the outcome of the LFGRA is based on the assumption that the site's surrounding environment would remain unchanged from the present day to the time for which the LFGRA has been completed (i.e. 2066/747 as identified in Section 6—~~it is recognised that the landfill will have a longer operational life than this~~). ~~This year was selected as it will be the year with the maximum estimated LFG emissions rates (as per the model in Section 4) and where final capping and LFG collection measures would have been installed at the site.~~

~~Whilst it is also likely that the installed engineering measures would adequately manage LFG, this point in time is also poses a risk in relation to possibly increasing subsurface gas migration (i.e. due to placement of final cap and final tune of LFG system). Therefore, we have selected this year as the final year of the LFGRA. However, from a risk assessment basis, this year is considered a reasonable point in time to assess landfill gas risks as a number of LFG related risks are typically present during the operational period of a landfill. Furthermore, this year approximately reflects the likely term of any resource consent).~~

Due to the site not yet being operational, and no monitoring data being available, GHD has completed a preliminary LFGRA at this time. This is documented in the following sections. The LFGRA should be updated once ~~the~~ LFG monitoring data ~~from Stage 2~~ is available for the site during its project life.

4.25.2 Source, pathways and receptors

4.2.15.2.1 Source

The primary source of the LFG at the site is the waste materials that will be landfilled at the site, specifically the organic and biodegradable components, which are likely to generate LFG under appropriate anaerobic conditions.

The key factors that need to be considered include the type of LFG emissions (i.e. methane and carbon dioxide), the total quantities of LFG emitted and the period over which the LFG emissions would occur. Other aspects to consider include:

- The lower reaches of some gullies at the landfill are infilled with relatively recent alluvial deposits containing significant amounts of organic materials that have the potential to generate gas. However, it is noted these deposits will be removed from beneath the landfill footprint (where they occur) and appurtenant structures during site development for reuse as landfill cover when the site is operational.
- The site's geology consists of localised thin interbeds and lamination of organic mudstone/lignite that has the potential to generate gas. However, it is noted that this is a small percentage of the overall rock mass and the Henley Breccia generally has a very low permeability and the likelihood of gas movement through the rock mass would be low.

- Groundwater elevation is generally deep within the breccia unit (~ 20 metres below ground level).
- Constructed landfill cells at the site would have been lined with a Flexible Membrane Liner (FML) and Compacted Clay Liner (CCL) or similar – see Section 3 of the Design Report.
- The site will have a leachate management system installed and will be operational upon commencement of landfill operations.
- The LFG emission model (refer to Section 4.60) suggests that the LFG emission rate will be approximately 1,176,743.9 m³/h during 2067,647.
- It is anticipated that the site will have an active LFG collection and treatment system installed and operational within ~~two~~ approximately three years of landfilling operations commencing (i.e. by 2031,025). This system would be progressively expanded across the waste mass with time.
- The carbonaceous shale deposit located at the site may be another alternative source of ground gas at the site (Victoria University of Wellington 2016), albeit that they comprise a relatively small amount of the rock mass and the rock mass has a very low permeability according to GHD (2020c) *Waste Futures – Smooth Hill Landfill Geotechnical Interpretive Report*.
- It is anticipated that ~~the all~~ landfill stages that have been filled by 2067,647 (Stages 1 ~~and to 42~~) will be covered by final cap at that time.

4.2.25.2.2 Pathways

There are a number of potential emission pathways that LFG could be emitted from the landfilled waste including the following:

- Through the landfill's surface and associated penetrations
- Through the subsurface geology (unsaturated zone)
- Through the subsurface geology (saturated zone – leachate and groundwater)
- Through subsurface services
- Through the proposed LFG collection and treatment/destruction system

It is noted that:

- There are currently no subsurface services along Big Stone Road on the southern boundary of the landfill. It has been assumed that this will continue to be the case in 2067,647.
- The surface water management infrastructure (e.g. stormwater drains and groundwater drainage) may act as release points or barriers to subsurface LFG movement in these locations. The landfill management plan will address worker safety and confined space entry procedures where LFG may be present.
- Noting extensive LFG engineering is proposed to be installed, functional and maintained for the site over its life (such as flare, LFG collection, lining system and landfill capping), the real risk of LFG emissions migrating via the identified pathways are considered to be low at point of closure.

4.2.35.2.3 Receptors

There are a number of potential receptors that have been identified for LFG emitted from the site including the following:

- On-site and off-site workers
- On-site visitors
- On-site subsurface services
- On-site buildings and structures
- Off-site residents
- Off-site buildings and structures
- Off-site visitors
- On-site and off-site flora
- On-site and off-site fauna
- On-site and off-site air
- Global climate
- Groundwater

GHD has identified all residential, industrial and commercial properties within 3.5 km of the site in existence at the time this report was prepared. There are currently a number of rural residential properties northwest of the site between 1.5 and 2.5 km from the landfill footprint. Three rural residences are also located southeast of the site, within 1 km of the landfill footprint. The nearest sensitive receptor (a residential property) is 731 Big Stone Road, approximately 380 metres from the landfill footprint. In this report it has been assumed from a LFG risk perspective that this property will continue to remain the nearest sensitive receptor in 206747. It is recognised that the [Dunedin City Council \(2019\) 2nd Generation District Plan \(2GP\) District Plan](#) allows for dwellings to be potentially erected on surrounding properties that are closer to the landfill footprint than 731 Big Stone Road. The closest properties to the landfill footprint where dwellings could be constructed are to the south and south east of the landfill. These properties are currently operated as forestry blocks and it is considered unlikely that dwellings would be erected upon them, or if they were, that any such dwellings would be closer than 380 metres to the ~~operational~~ landfill site, between now and 2067647.

4.35.3 Conceptual site models

Based on the identification of source-pathway-receptor linkages between LFG emitted from the site and the adjacent environment, as described above, GHD have developed a visual ~~representation of the~~ preliminary conceptual site models (CSMs). The CSMs represent a period in the site's future life (assuming it was approved) when filling in ~~Stages 1 and 2~~ Stage 4 has been completed (refer drawing C203) and the final LFG collection system has been installed. This is estimated to be approximately 3924 years³ after landfilling operations have commenced at the site i.e. 2067647. The CSMs are provided in Appendix C.

4.45.4 Sensitivity of receptors

Following consideration of the source, pathways and receptors, GHD considers that the relative sensitivities of the identified receptors are as illustrated in Figure 5-1 below.

³ Based on 6000,000 tonnes per annum of waste placement [? where's this footnote link to?](#)

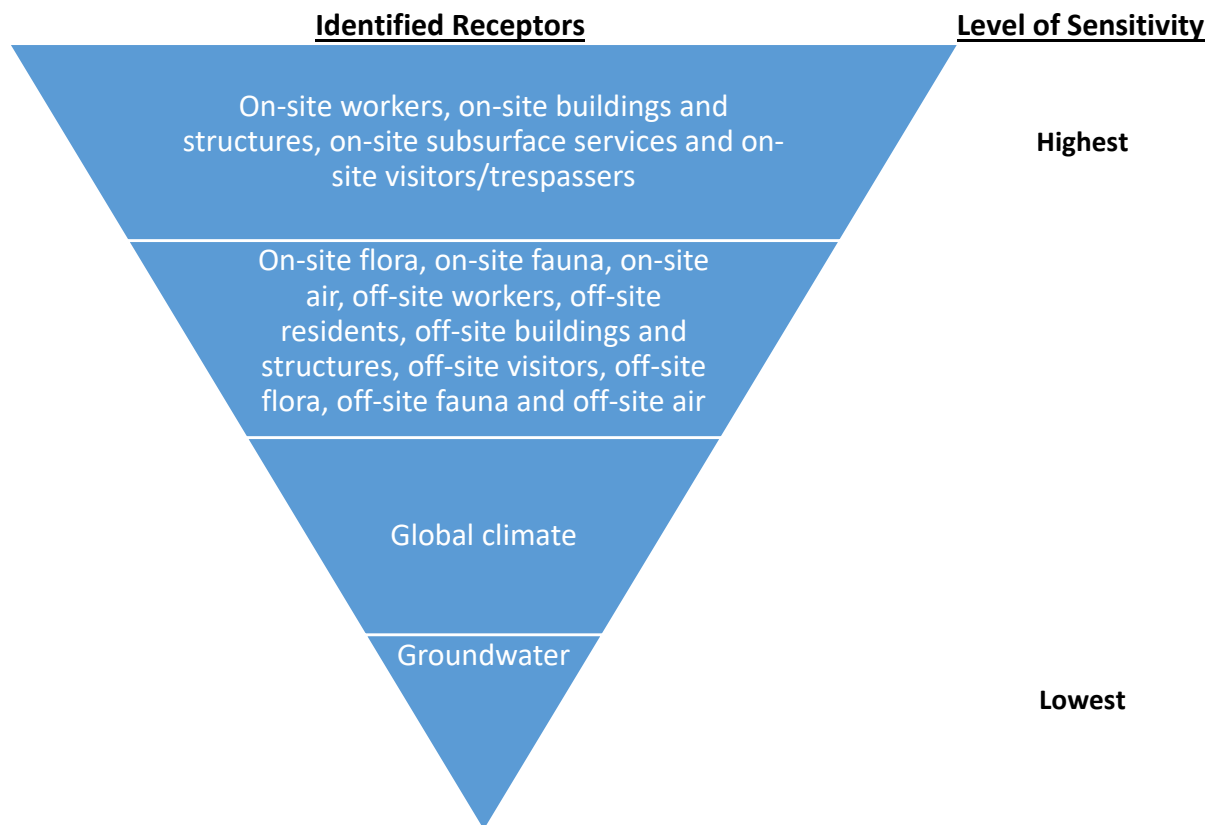

Figure 5-1 Relative sensitivities of identified receptors

4.55.5 Potential impacts upon receptors

As highlighted in Section 2.1, LFG can cause health, safety, amenity and/or environmental impacts upon receptors due to the gases it contains. The available information (including the site CSMs) suggests that there are a number of potentially complete source-pathway-receptor linkages between the LFG emitted by the site and the receptors identified in Section 5.2.3. Should these linkages be complete, they have the potential to result in a range of LFG related impacts upon these receptors.

GHD undertook a preliminary assessment of the potentially complete source-pathway-receptor linkages and potential impacts to receptors with consideration of the LFG emission model. This process identified key risks, which are summarised in the following section.

4.65.6 Key risks

The key risks associated with LFG at the site during 2067-647 are considered to be as follows

- Impact upon on-site workers and visitors.
- Impact upon on-site buildings and -structures
- Impact upon future on-site subsurface services

Risks presented to other potential receptors are currently considered to be of a lower significance.

4.75.7 Summary

Given the key risks identified above and the magnitude and longevity of the estimated emission rates identified in Section 4.2, a range of LFG management measures will likely be required at the site for many decades to appropriately manage the LFG emitted. These LFG

management measures include active LFG management (i.e. collection and combustion), regular monitoring and appropriate waste covering and containment systems.

To assist with the development of these management measures, GHD has reviewed the relevant regulatory documents / guidelines for LFG management at landfills in New Zealand. The key points of note in relation to these documents are provided in the following section.

5.6. Regulatory documents and guidelines

5.16.1 Overview

There are two key documents in relation to LFG management in New Zealand. These are:

- The National Environmental Standards for Air Quality (Air Quality NES) Regulations 2004
- Waste Management Institute New Zealand (WasteMINZ) (2018) Technical Guidelines for Disposal to Land

Furthermore (although considered of lesser direct relevance) the following two documents exist:

- Climate Change Response Act 2002
- Ambient Air Quality Guidelines 2002 update

To assist with the development of potentially appropriate LFG management measures for the site, GHD has reviewed these four documents and identified the key points of note within them in relation to LFG management at the site. These points of note are presented in the following sections

5.26.2 ~~The National Environmental Standards for Air Quality (Air Quality NES) Regulations 2004~~

~~The~~ Air Quality NES Regulations 2004 are regulations made under the Resource Management Act 1991, which aims to set a guaranteed minimum level of health protection for all New Zealanders. This includes controlling greenhouse gas emissions at landfills. The following clauses of the Air Quality NES apply to the site with regards to LFG management.

Clause 25: Application of regulations 26 and 27

(1) *Regulations 26 and 27 apply to a landfill if—*

(a) the landfill—

(i) has a total capacity of not less than 1 million tonnes; and

(ii) contains not less than 200 000 tonnes of waste; and

(iii) is or is likely to be accepting waste; and

(b) the waste in or to be included in the landfill is likely to consist of 5% or more (by weight) of matter that is putrescible or biodegradable.

(2) *However, regulations 26 and 27 do not apply to a landfill until 8 October 2007 if the landfill—*

(a) has a total capacity of not less than 1 million tonnes of waste; and

(b) on 8 October 2004—

(i) contains not less than 200 000 tonnes of waste; and

(ii) is accepting waste; and

(c) does not operate a gas collection system.

(3) *Regulations 26 and 27 do not apply to a cleanfill.*

Clause 26: Control of gas

(1) No person may allow the discharge of gas to air from a landfill.

(2) Subclause (1) does not apply if the landfill has a system for the collection of gas from the landfill—

(a) That is designed and operated to ensure that any discharge of gas from the surface of the landfill does not exceed 5 000 parts of methane per million parts of air; and

(b) In which the gas is—

(i) flared in accordance with regulation 27; or

(ii) used as a fuel or for generating electricity.

Clause 27: Flaring of gas

(1) If gas collected at a landfill is destroyed by flaring,—

(a) The system for the principal flare or flares must—

(i) comply with the requirements in subclause (2); or

(ii) achieve at least the same effect as the system in subclause (2); and

(b) The system for the backup flare must—

(i) comply with the requirements in subclause (3); or

(ii) achieve at least the same effect as the system in subclause (3).

(2) The system for a principal flare must—

(a) have a flame arrestor; and

(b) have an automatic backflow prevention device, or an equivalent device, between the principal flare and the landfill; and

(c) have an automatic isolation system that ensures that, if the flame is lost, no significant discharge of unburnt gas from the flare occurs; and

(d) have a continuous automatic ignition system; and

(e) have a design that achieves a minimum flue gas retention time of 0.5 seconds; and

(f) be designed and operated so that gas is burned at a temperature of at least 750°C; and

(g) have a permanent temperature indicator; and

(h) have adequate sampling ports to enable emission testing to be undertaken; and

(i) provide for safe access to sampling ports while any emission tests are being undertaken.

(3) The system for a backup flare must have—

(a) a flame arrestor; and

(b) an automatic backflow prevention device, or an equivalent device, between the backup flare and the landfill; and

(c) an automatic isolation system that ensures that, if the flame is lost, no significant discharge of unburnt gas from the flare occurs; and

(d) a continuous automatic ignition system.

(4) A principal flare must be operated at all times unless it has malfunctioned or is shut down for maintenance.

(5) A backup flare must be operated if, and only if, a principal flare is not operating.

5.36.3 WasteMINZ (2018) Technical Guidelines for Disposal to Land

The WasteMINZ (2018) Technical Guidelines for Disposal to Land, dated August 2018 (WasteMINZ guidelines) provides technical guidance relating to the siting, design, operation and monitoring of landfills in New Zealand, including LFG management. The key points outlined in the WasteMINZ Guidelines regarding LFG management are as follows:

- The base of an extraction well to be typically targeted at least 5 metres above the liner of the landfill
- LFG well spacing of 50 to 70 metres
- LFG well spacing of no greater than 30 metres from the edge of the waste mass
- Pipework and extraction equipment to be designed for gas flows of the maximum landfill gas emission throughout the design life of the pipework system
- Utilisation equipment to be designed for the maximum collected landfill gas throughout the design life of the landfill gas management system
- The upper 2 to 5 metres of the well riser should be non-perforated to prevent air entrainment
- Landfill gas monitoring should be undertaken at all landfill sites, primarily to determine whether gas production is giving rise to a hazard or nuisance.

5.46.4 Climate Change Response Act 2002

The Climate Change Response Act 2002 provides a legal framework, which requires New Zealand to meet its obligations relating to climate change. An amendment of the Act in 2008 put in place the Emissions Trading Scheme (ETS) to reduce domestic emissions, including emissions from landfill. The Climate Change Response Act 2002 requires landfill operators to report and surrender emissions units in proportion to calculated methane emissions from the biodegradation of organic waste from their landfills.

In 2019, an additional amendment of the Act was undertaken to include emissions reduction targets for 2050. Specifically for methane, the following targets were established in a calendar year:

- 10% less than 2017 emissions by the calendar year beginning on 1 January 2030.
- 24% to 47% less than 2017 emissions by the calendar year beginning on 1 January 2050 and for each subsequent calendar year.
- GHD considers that the installation and operation of the active LFG collection and treatment system may assist in meeting the emission reduction targets identified above by reducing the discharges associated with this facility.

5.56.5 Ambient Air Quality Guidelines 2002 Update

The New Zealand ambient air quality guidelines (2002 update) (Ambient Air Quality Guidelines) outlines the ambient air quality guideline values for New Zealand, and provides guidance on how to use these values to manage air quality under the Resource Management Act 1991. The guideline values are the minimum requirements that outdoor air quality should meet in order to protect human health and the environment. If these guideline values are exceeded

appropriate measures should be implemented to improve air quality. Air quality potential impacts and mitigation measures are discussed further in the Air Quality Report (GHD 2020).

5.66.6 International guidance

It is noted that there is a range of international guidance available in relation to LFG assessment and management in Australia, the United Kingdom, Canada, the United States of America and elsewhere. Where information or guidance has been limited in the New Zealand documents identified above, GHD has applied other relevant international guidance. The international guidance that has been considered in such cases is identified in Section 10.

6.7. Suggested LFG management measures

Based on the outputs of the works presented in the preceding sections of this report, the following management measures are considered to be appropriate for the LFG emitted by the site:

- Installation and appropriate construction quality assurance (CQA) of a low permeability basal and sidewall lining system. It is anticipated that all landfill cells will incorporate this measure and that it will consist of FML and [EGCL](#)⁴ or similar (see section 3 of the Design [Report](#)) which will reduce the likelihood of subsurface LFG emissions.
- Installation, appropriate CQA and operation of a leachate management system at the site. Leachate pumping systems to be designed and operated in accordance with relevant standards in relation to LFG as applicable (e.g. *AS/NZS 2381.1.1:2005*).
- Regular covering of waste with appropriate daily and intermediate cover materials. It is anticipated that daily cover will be applied at the end of each day's waste placement and intermediate cover will be placed on areas where further waste will not be placed for one month⁵.
- Progressive capping and rehabilitation of the site with a low permeability landfill cap over the site's lifetime. It is anticipated that a final cap that meets the WasteMINZ 2018 Technical Guidelines for Disposal to Land for a Class 1 landfill will be installed at the site⁶.
- Progressive installation, operation and monitoring of an active LFG collection, treatment and destruction system (i.e. gas wells, pipework, manifolds, flares and/or engines) that is suitable for the quantity of LFG emitted by the site as development progresses. It is anticipated that LFG management will commence after [approximately fourtwo](#) years of landfill operations. Emissions from the combustion of LFG at the flares and/or engines must meet the requirements of the Air Quality NES and the ambient air quality guidelines at agreed locations. Emission issues are discussed further in the Air Quality Report (GHD 2020).
- Appropriate design, installation and validation of buildings and structures and subsurface services (for example in accordance with *AS/NZS 2381.1.1:2005* if relevant) on-site to prevent LFG entering and/or accumulating within them.
- Design, installation and implementation of an appropriate LFG monitoring network and program. This network and program should be reviewed and potentially updated on an ongoing basis as conditions change at/adjacent to the site over time.
- Completion of a detailed LFGRA prior to waste filling occurring and on-going review and update of that document as conditions change at/adjacent to the site over time. This detailed LFGRA should further consider / investigate organic mudstone / lignite as a [potential](#) source of ground gas at the site
- Development and implementation of appropriate work, health and safety procedures for on-site workers who may be at risk of being exposed to LFG emissions.

In this report, GHD has developed concept designs for:

4GHD (202149a) Waste Futures Phase 2 – Work stream 3 Smooth Hill Landfill, Landfill Concept Design Report, Section 3.9

5 GHD (202149a) Waste Futures Phase 2 – Work stream 3 Smooth Hill Landfill, Landfill Concept Design Report, Section 7.3.2

6 GHD (202149a) Waste Futures Phase 2 – Work stream 3 Smooth Hill Landfill, Landfill Concept Design Report, Section 3.12

- An active LFG collection and treatment/destruction system
- A perimeter LFG monitoring bore network

The basis for the concept designs and the concept designs themselves are provided in the following sections.

7.8. Concept design of active LFG collection and treatment/destruction system

7.18.1 Overview

The overarching goals for LFG management at the proposed landfill are as follows:

- To optimise the overall quantity of LFG collected from the deposited waste and thereby reduce potentially adverse outcomes (such as fugitive emissions and LFG related odour).
- To comply with the LFG related requirements of the Air Quality NES.
- To comply with the LFG related recommendations of the WasteMINZ Guidelines and the Ambient Air Quality Guidelines.
- To address the prioritised risks identified from by the preliminary LFGRA.

As such, the emphasis of the concept design for the LFG collection and treatment/destruction system (the system) is on the environmental control of LFG as opposed to LFG utilisation for electricity (although it is noted that this may be possible).

7.28.2 Design goals

The design goals for the system are presented in Table 8-1. They have been considered in the development of the concept design of the system (as relevant).

Table 8-1 Design goals for proposed LFG collection and treatment/destruction system

Design criteria/requirements	Goal
Environmental	<ol style="list-style-type: none"> 1. Meet any required noise emission levels at all times. 2. Minimise potential brush/forest fire risks (on and off-site). 3. Not cause significant dust or odour emissions. 4. Enable the site to be monitored in accordance with WasteMINZ Guidelines. 5. Allow leachate monitoring and possible extraction to occur at individual vertical LFG wells. 6. Reduce fugitive emissions of LFG from the landfill
Legal/Statutory	<ol style="list-style-type: none"> 1. Comply with the relevant requirements of the Air Quality NES 2. Comply with the LFG related recommendations of the WasteMINZ Guidelines and the Ambient Air Quality Guidelines
Operational	<ol style="list-style-type: none"> 1. Be able to be readily and practically and economically operated, monitored and maintained.

Design criteria/requirements	Goal
Technical	<ol style="list-style-type: none"> 1. Be of suitable capacity to manage the anticipated rate of LFG collected allowing for any uncertainties with consideration to the peak LFG emission rate of approximately 4,9271,177 m³/h. 2. Minimise condensate collection within the pipework and ensure adequate drainage of condensate from the pipework. 3. Minimise the likelihood of damage due to settlement. 4. Minimise the likelihood of subsurface landfill fires developing due to air being drawn into the landfilled waste mass. 5. Appropriate interface with existing and potential future (where anticipated) site infrastructure. 6. Minimise the likelihood of vandalism/damage/interference. 7. Minimise the likelihood of bushfire related damage (both by and to the LFG collection and treatment/destruction system).

7.38.3 Concept design

Based on the information presented in this report, particularly Section 8.1 and Section 8.2, GHD developed a concept design and associated details of the concept system post closure of the landfill. These are shown on the drawings provided in Appendix C. The reason that the system is shown at closure is so that the complete system can be shown rather than just a portion of it. It is noted that the system would be constructed progressively and follow the filling of the site.

7.48.4 Key elements of system

The key elements of the system are as follows:

- A primary flare ([elevated-enclosed](#) type) and a backup flare (candlestick type) to combust the collected LFG.
- Ability to utilise LFG fuelled engine(s) to combust the collected LFG if there proves to be enough LFG collected to allow this in the future. A typical engine example is the GE Jenbacher JMS 320 GS-B.L provided in Attachment D.
- LFG collection pipework (extraction wells, condensate drainage points, interconnecting pipework) that will be progressively expanded across the site in line with filling activities.
- Main condensate pots to be installed in key locations (to be assessed during the detailed design). These vessels could be self-draining into the landfilled waste mass or pumped out.
- Horizontal LFG wells to be installed during filling to optimise LFG collection, with vertical wells to be installed post filling.
- Individual LFG extraction wells (whether horizontal or vertical) to be installed and connected to manifold structures where they can be individually monitored and adjusted

as required. Certain LFG extraction wells uphill of the relevant manifolds may require condensate 'J-traps' to be installed (to be assessed during detailed design).

- Approximately ~~106203~~ vertical LFG extraction wells to be installed at approximately 50 metre centres between each individual wells. ~~3252~~ of the wells along the boundary are to be installed no greater than 30 metres from the waste footprint boundary (i.e. edge of the waste mass) in accordance with the recommendations of the WasteMINZ Guidelines.
- Individual vertical LFG extraction wells to have wellheads at the ground surface at the point of penetration through the final cap. The wellheads would allow the well to be monitored and adjusted for LFG. Additionally, the wellheads would also allow leachate to be monitored and extracted by a surface operated portable pump or a submersible pump installed in the well, if required. The pipework for the proposed vertical LFG extraction wells to be 160 mm outer diameter (OD) and wells to be installed to a target depth of at least 5 metres above the base of the landfill to minimise the risk of penetrating the proposed liner system as recommended by the WasteMINZ Guidelines.
- Temporary horizontal LFG collection lines to be installed as the landfill is progressively filled.

7.58.5 Key assumptions for active LFG collection and treatment/destruction system

In addition to the assumptions detailed elsewhere in this report, GHD adopted the following key assumptions during the development of the concept design for the system:

- A specialist LFG consultant and contractor will ultimately complete detailed design of the system and install, operate, monitor and maintain it.
- A drill rig employed by the specialist LFG contractor would be capable of safely installing the vertical LFG extraction wells into the landfilled waste mass at the site to the required depths and diameters.
- The horizontal and vertical wells would be installed by a specialist LFG contractor in general accordance with the concept design drawings
- The horizontal wells would be progressively expanded across the site during landfilling operations.
- The installation of vertical wells would typically occur once intermediate cover and/or final cap is placed in areas filled to the required height. This would be assessed and confirmed at the relevant time.
- The specialist LFG contractor will carefully consider the required screening depths of the gas wells prior to their installation. The specialist LFG contractor will ensure that the wells:
 - Are not screened in the earthen cover materials.
 - Are installed so as to minimise the likelihood of causing air ingress into the waste.
 - Are installed so as to minimise the likelihood of interference with the installed horizontal wells.
- Only preliminary consideration has been given to potential environmental and safety issues associated with the construction and operation of the proposed system. These issues should be further reviewed and addressed during the detailed design stage.

8.9. Concept design of perimeter LFG monitoring bore network

8.19.1 Overview

Based on the overarching goals for LFG management at the site identified in Section 8.1 and the outputs of the works presented in the preceding sections of this report, GHD developed a concept design for a preliminary perimeter LFG monitoring bore network (bore network) for the site.

This concept design was developed with consideration of the guidance provided in EPA Victoria (2015) Best Practice Environmental Management: Siting, design, operation and rehabilitation of landfills (BPEM). The BPEM was selected as the principal point of reference for the design of the bore network as detailed guidance on this matter is not provided in the WasteMINZ Guidelines.

The BPEM outlines various points of note in relation to the design of perimeter LFG monitoring bore networks. Some points of note are provided below:

The aim of a LFG monitoring bore network is to intercept any LFG escaping laterally from a landfill site and identify its location. As such, LFG monitoring bores must be installed at appropriate locations, drilled to depths suitable to intercept all gas movement paths, constructed appropriately to intercept gas and should be determined based on the findings of a LFGRA.

The following are key design factors:

- *Bore location and spacing*
- *Bore depth*
- *Bore construction design*
- *Bore installation CQA*

Typically it is expected that a LFG monitoring bore network will:

- *Target sensitive receptors such as dwellings*
- *Encircle the entire landfilled waste mass*
- *Be installed into the local geology (not into waste or fill materials)*

EPA recommends that LFG monitoring bores are sited at least 20 metres from the boundary of the landfilled waste, to ensure validity of the LFG monitoring data subsequently obtained.

GHD subsequently considered the BPEM guidance and developed a preliminary concept for the bore network as discussed in the following sections.

8.29.2 Design goals

The design goals for the bore network are presented in Table 9-1. These were considered in the development of the concept design of the bore network (as relevant).

Table 9-1 Design goals for proposed perimeter LFG monitoring bore network

Design criteria/requirements	Goal
Environmental	<ol style="list-style-type: none"> 1. To not cause significant dust or odour emissions. 2. To enable the LFG to be monitored in accordance with the LFG related recommendations of the WasteMINZ Guidelines and BPEM
Legal/Statutory	<ol style="list-style-type: none"> 1. To comply with the LFG related recommendations of the WasteMINZ Guidelines and BPEM
Operational	<ol style="list-style-type: none"> 1. To be able to be readily and practically accessed, monitored and maintained. 2. To not obstruct other on-site operations / activities. 3. To appropriately interface with existing and potential future (where anticipated) site infrastructure.
Technical	<ol style="list-style-type: none"> 1. To be able to intercept any LFG escaping laterally from the site and identify its location. 2. To be installed at appropriate locations, drilled to depths suitable to intercept all gas movement paths, constructed appropriately to intercept gas and be determined based on the findings of a LFGRA. 3. To target sensitive receptors such as dwellings. 4. To encircle the entire landfilled waste mass. 5. To be installed into the local geology (not into waste or fill materials). 6. To be sited at least 20 metres from the boundary of the landfilled waste. 7. To minimise the likelihood of vandalism/damage/interference.

8.39.3 Concept design

Based on the information presented in this report, GHD developed two concept designs for the preliminary [monitoring](#) bore network prior to commencement of the landfilling operations at the site. The reason that the bore network is shown prior to filling is such that background monitoring data can be obtained prior to filling works commencing to assist with confirming potentially naturally present ground gas concentrations at the site. It is noted that the bore network may need to expand [or updated](#) with time at the site for example due to monitoring results obtained and/or changes to adjacent receptors [and as the site is developed](#).

These concept designs are shown on the drawings provided in Appendix C with associated explanation of their basis provided in the following sections.

8.49.4 BPEM bore network

As identified above, the BPEM document provides detailed guidance in relation to the design and spacing of perimeter LFG monitoring bores. The BPEM contains a table⁷ that outlines default bore spacings based on the type of geology in which the landfill site is located and the proximity of 'development' to the site boundary. These defaults can be amended by the findings of a LFGRA.

Therefore, GHD's first step in developing the preliminary bore network was to identify how many LFG bores may be required if no LFGRA had been completed and Table B.2 was adopted verbatim.

This step identified that the required bore spacings would be as per Table 9-2 below, assuming that the maximum bore spacing from Table B.2 was adopted and on the understanding that the bedrock at the site is breccia (i.e. fissure or fracture flow dominated strata).

Table 9-2 BPEM recommended LFG monitoring bore spacing for fissure or fracture flow-dominated permeable strata

Site description	Maximum bore spacing (m)
Fissure or fracture flow-dominated permeable strata (e.g. blocky sandstone or igneous rock); no development within 250 metres	50
Fissure or fracture flow-dominated permeable strata (e.g. blocky sandstone or igneous rock); development within 250 metres	50
Fissure or fracture flow-dominated permeable strata (e.g. blocky sandstone or igneous rock); development within 150 metres	20

The BPEM recommended LFG bore monitoring network resulted in ~~5463~~ LFG monitoring bores being required around the site. Given the site's local environs, the findings of the preliminary LFGRA and other works completed in this report, this number of wells is currently considered to be excessive by GHD. Therefore, GHD developed a refined preliminary bore network design with a reduced number of monitoring bores. The reduced LFG monitoring bore network is discussed in the following section.

8.59.5 Preliminary LFG monitoring bore network

As identified above, based on the LFGRA completed in this report, GHD reviewed the BPEM bore network and developed what is considered to be a more reasonable bore network for the site at this time. This preliminary bore network:

- Increased the bore spacing (greater than 50 m) from the BPEM bore network on the northern, western, south-western and south-eastern boundaries due to a lack of current and perceived lack of future receptors for LFG in those areas within 250 metres of the waste footprint boundary.
- Adopts a bore spacing of 50 metres along part of the southern boundary of the site due to one current off-site receptor approximately 380 metres south of the waste footprint boundary.

⁷ Table B.2: Recommended landfill gas monitoring bore spacing

- Adopts a bore spacing of 20 metres along the ~~north-eastern and eastern~~ boundary due to proposed ~~and historical~~ on-site receptors (buildings) in that area within ~~500-150~~ metres of the waste footprint boundary.
- This resulted in a bore network of ~~4632~~ LFG monitoring bores being needed around the site. GHD considers that this preliminary system is more reasonable at this time based on the available information. It is noted that additional bores may be required in the future based on monitoring results.

8.69.6 Key assumptions for perimeter LFG monitoring bore network

In addition to the assumptions detailed elsewhere in this report, GHD adopted the following key assumptions during the development of the concept design for the preliminary bore network:

- A specialist consultant will ultimately develop a detailed design for the LFG bores.
- A specialist drilling contractor will ultimately install the LFG monitoring bores.
- The suggested LFG bore locations are readily and safely accessible with a drilling rig and under DCC control.
- A drill rig employed by the specialist drilling contractor would be capable of safely installing the LFG bores at the identified locations and to the appropriate depths and diameters.
- The LFG bore network would be installed and monitored on a minimum monthly frequency for LFG at least 12 months prior to the placement of waste in order to obtain background ground gas data for the site prior to filling.
- Only preliminary consideration has been given to potential environmental and safety issues associated with the construction and operation of the proposed system. These issues should be further reviewed and addressed during the detailed design stage.

9.10. Reliance

- British Columbia: Ministry of Environment (2010) Landfill Gas Management Facilities Design Guidelines, March 2010
- Dunedin City Council (2019) 2nd Generation District Plan (2GP). Retrieved from <https://www.dunedin.govt.nz/council/district-plan/2nd-generation-district-plan>
- EPA Victoria (2015), Best practice environmental management - Siting, design, operation and rehabilitation of landfills, EPA Victoria Publication 788.3, August 2015
- GE Power & Water (2013a) Jenbacher Type 3 Technical Specifications
- GE Power & Water (2013b) JMS 320 GS-BL, Biogas 1.063kW el.
- GHD (2021a) Waste Futures Phase 2 – Work Stream 3 Smooth Hill Landfill, Landfill Concept Design Report
- GHD (2021b) Waste Futures Phase 2 – Work Stream 3, Smooth Hill Consenting – Geotechnical Factual Report
- [GHD \(2021c\) Waste Futures – Smooth Hill Landfill Geotechnical Interpretive Report](#)
- [GHD \(2021d\) DCC Smooth Hill Consenting Air Quality Assessment](#)
- Ministry for the Environment and Ministry of Health (New Zealand) (2002) Ambient Air Quality Guidelines, 2002 Update
- Ministry for the Environment (New Zealand) (2004) Module 2: Hazardous Waste Guidelines, Landfill Waste Acceptance Criteria and Landfill Classification
- Ministry for the Environment (2001) A Guide for the Management of Closing and Closed Landfills in New Zealand
- Ministry for the Environment (2019) Climate Change Response (Zero Carbon) Amendment Act
- Resource Management (National Environmental Standards for Air Quality) Regulations 2004, July 2017
- NIWA (2015) The Climate and Weather of Otago, 2nd edition
- Victoria University of Wellington (2016) Geology of Dunedin
- WasteMINZ (2018a), Technical Guidelines for Disposal to Land, August 2018
- WasteMINZ (2018b), Technical Guidelines for Disposal to Land: Appendices, August 2018
- Windsor Engineering (2019) Biogas Flare – GF1000

10.11. Limitations

This report: has been prepared by GHD for Dunedin City Council and may only be used and relied on by Dunedin City Council for the purpose agreed between GHD and the Dunedin City Council as set out in Section 1 of this report.

GHD otherwise disclaims responsibility to any person other than the Dunedin City Council and Council officers, consultants, the hearings panel and submitters associated with the resource consent and notice of requirement process for the Smooth Hill Landfill Project arising in connection with this report. GHD also excludes implied warranties and conditions, to the extent legally permissible.

The services undertaken by GHD in connection with preparing this report were limited to those specifically detailed in the report and are subject to the scope limitations set out in the report.

The opinions, conclusions and any recommendations in this report are based on conditions encountered and information reviewed at the date of preparation of the report. GHD has no responsibility or obligation to update this report to account for events or changes occurring subsequent to the date that the report was prepared.

The opinions, conclusions and any recommendations in this report are based on assumptions made by GHD described in this report. GHD disclaims liability arising from any of the assumptions being incorrect.

GHD has prepared this report on the basis of information provided by Dunedin City Council and others who provided information to GHD (including Government authorities), which GHD has not independently verified or checked beyond the agreed scope of work. GHD does not accept liability in connection with such unverified information, including errors and omissions in the report which were caused by errors or omissions in that information.

Appendices

Appendix A – Landfill gas model parameters, assumptions and justifications table



Client	Dunedin City Council		
Prepared by	Fabrice Cheong (04/03/2021)	Checked by	Matt Welsh
Subject	Proposed Smooth Hill Landfill - Parameters, Assumptions and Justification Table for Landfill Gas Model (LandGEM 3.02)	Job no.	12506381
Revision	1	Date	28 May 2021 16 March 2021

Model Parameter	Model Assumption	Justification
Methane generation rate (k values)	Methane generation rate (k value): 0.05 year ⁻¹	<p>A value of 0.05 year⁻¹ has been selected based on the typical k-values used in New Zealand landfills outlined on pages 27 to 28 of WasteMINZ (2018) <i>Technical Guidelines for Disposal to Land: Appendix B</i>.</p> <p>It is noted that a site specific k-value can be calculated and applied using the Pierce et al (2005) formula identified on page 27 of the WasteMINZ (2018) <i>Technical Guidelines for Disposal to Land: Appendix B</i>. GHD calculated this value to be 0.0164 year⁻¹ (refer to Attachment 1 for calculations).</p> <p>GHD revisited the calculations contained in Attachment 1 in March 2021 with consideration of annual average rainfall data provided in NIWA (2015) (for years 1981 to 2010) and from Smooth Hill's meteorological station (for years 2016 to 2019). It was found that the calculated k-value remained unchanged at 0.0164 year⁻¹.</p> <p>GHD subsequently reviewed the calculated k-value against the k-values presented on pages 27 to 28 of the WasteMINZ (2018) <i>Technical Guidelines for Disposal to Land: Appendix B</i> and those presented on page 16 of the US EPA (2005) <i>LandGEM version 3.02 User's Guide</i> default values. GHD concluded that the calculated k-value was likely to be too low for the site based on the guidance in these documents and the calculated k-value was therefore discarded in favour of the value of 0.05 year⁻¹ identified above.</p>



Model Parameter	Model Assumption	Justification												
Potential methane generation capacity (L _o)	Potential methane generation capacity (L _o values): 100 m ³ /Mg	<p>The adopted value is based on the lower value for a typical NZ landfill identified on page 26 of Appendix B of WasteMINZ (2018) <i>Technical Guidelines for Disposal to Land: Appendix B</i> (i.e. 100 m³/tonne) and the inventory emission (i.e. 100 m³/Mg) for a conventional landfill as outlined on page 16 of the US EPA (2005) <i>LandGEM version 3.02 User's Guide</i>, which is based on the US EPA (1998) <i>Compilation of Air Pollutant Emission Factors, AP-42, Vol. 1: Stationary Point and Area Sources</i>.</p> <p>GHD notes that 1 Mg is the same as one metric tonne.</p>												
Nonmethane organic compound concentration (NMOC) (ppmv)	NMOC: Inventory Co-disposal – 2,400 ppmv	<p>The adopted NMOC value is the inventory default where co-disposal of hazardous waste has occurred (or is proposed to be done in the case of this site) (i.e. 2,400 ppmv). The adopted value is based on page 17 of the US EPA (2005) <i>LandGEM version 3.02 User's Guide</i>.</p> <p>WasteMINZ (2018) <i>Technical Guidelines for Disposal to Land: Appendix B</i> provides no New Zealand specific value for this parameter.</p>												
Methane content (% by volume)	Methane content: CCA – 50% by volume (default)	<p>The adopted value is the model default value as identified on pages 17 to 18 of the US EPA (2005) <i>LandGEM version 3.02 User's Guide</i> default values.</p> <p>This value is commonly used in greenhouse gas estimation for landfill sites in GHD's experience.</p>												
Estimated years of landfilling (calendar year)	The landfill commenced landfilling operations in 2028 and will cease in 2066 (39 years)	Based on a total airspace design capacity of 39 years as per Section 3.2.1 of GHD (2021) <i>Waste Futures Phase 2 – Workstream 3 Smooth Hill Landfill: Landfill Concept Design Report</i> to estimate the maximum LFG emissions that may be generated at the final stage of the landfill (i.e. worst case scenario).												
Quantity of waste landfilled per calendar year (Megagrams)	<table border="1"> <tr><td>2028</td><td>60,000</td></tr> <tr><td>2029</td><td>60,000</td></tr> <tr><td>2030</td><td>60,000</td></tr> <tr><td>2031</td><td>60,000</td></tr> <tr><td>2032</td><td>60,000</td></tr> <tr><td>2033</td><td>60,000</td></tr> </table>	2028	60,000	2029	60,000	2030	60,000	2031	60,000	2032	60,000	2033	60,000	<p>Projected waste inflow estimated from weighbridge records at Green Island landfill (Council's current landfill site) and as confirmed with Council as per Council (Alice Grace) e-mail '<i>RE: Smooth Hill – incoming waste and truck numbers</i>' dated 12 June 2019 – see AEE for description of waste quantity assumptions. GHD notes that 1 Mg is the same as one metric tonne.</p>
2028	60,000													
2029	60,000													
2030	60,000													
2031	60,000													
2032	60,000													
2033	60,000													



Model Parameter	Model Assumption	Justification
	2034 60,000	
	2035 60,000	
	2036 60,000	
	2037 60,000	
	2038 60,000	
	2039 60,000	
	2040 60,000	
	2041 60,000	
	2042 60,000	
	2043 60,000	
	2044 60,000	
	2045 60,000	
	2046 60,000	
	2047 60,000	
	2048 60,000	
	2049 60,000	
	2050 60,000	
	2051 60,000	
	2052 60,000	
	2053 60,000	
	2054 60,000	
	2055 60,000	
	2056 60,000	
	2057 60,000	



Model Parameter	Model Assumption	Justification
	2058 60,000	
	2059 60,000	
	2060 60,000	
	2061 60,000	
	2062 60,000	
	2063 60,000	
	2064 60,000	
	2065 60,000	
	2066 60,000	



Attachment 1 – K-value calculation

Average annual rainfall [for years 1981 to 2010](#) (r) Dunedin (Airport) approximately 5.5 km north west of the site based on NIWA (2015) *The Climate and Weather of Otago*, Page 16, Table 6 = 652 mm = 0.652 m

[Average annual rainfall from metService for Dunedin Airport for years 2016 to 2019 = 733 mm = 0.733 m.](#)

[Average annual rainfall for years 1981 to 2010 and 2016 to 2019 = \(\(30 years/34 years\)*652 mm\)+\(\(4 years/34 years\)*733 mm\) = 662 mm = 0.662 m](#)

$$K = 0.016e^{(0.04r)}$$

$$K = 0.016e^{(0.04 \times 0.662)}$$

$$K = 0.0164 \text{ year}^{-1}$$

Appendix B – Landfill gas model and calculations

Project Smooth Hill Landfill Approval for Consent
Subject 60 Mga Scenario LFG Generation Model
Revision 0
Prepared by Fabrice Cheong
Checked by Matt Welsh
Date 16/03/2021



Year	Total LFG ¹	Total LFG Emission Rates at 50%v/v ² Methane
	m3/year	m3/h
2028	0	0
2029	586711	67
2030	1144808	131
2031	1675687	191
2032	2180674	249
2033	2661032	304
2034	3117963	356
2035	3552610	405
2036	3966058	452
2037	4359342	497
2038	4733446	540
2039	5089304	581
2040	5427807	619
2041	5749801	656
2042	6056091	691
2043	6347444	724
2044	6624586	756
2045	6888213	786
2046	7138982	814
2047	7377521	842
2048	7604426	867
2049	7820265	892
2050	8025578	916
2051	8220877	938
2052	8406651	959
2053	8583365	979
2054	8751461	998
2055	8911358	1017
2056	9063457	1034
2057	9208139	1050
2058	9345764	1066
2059	9476677	1081
2060	9601205	1095
2061	9719660	1109
2062	9832338	1122
2063	9939520	1134
2064	10041475	1146
2065	10138458	1157
2066	10230711	1167
2067	10318464	1177

Year	Total LFG ¹	Total LFG Emission Rates at 50%v/v ² Methane
	m3/year	m3/h
2068	9815227	1120
2069	9336533	1065
2070	8881185	1013
2071	8448044	964
2072	8036028	917
2073	7644106	872
2074	7271299	829
2075	6916674	789
2076	6579343	751
2077	6258465	714
2078	5953236	679
2079	5662893	646
2080	5386711	615
2081	5123998	585
2082	4874097	556
2083	4636385	529
2084	4410266	503
2085	4195175	479
2086	3990573	455
2087	3795951	433
2088	3610820	412
2089	3434718	392
2090	3267205	373
2091	3107862	355
2092	2956290	337
2093	2812110	321
2094	2674961	305
2095	2544502	290
2096	2420405	276
2097	2302361	263
2098	2190073	250
2099	2083262	238
2100	1981660	226
2101	1885013	215
2102	1793080	205
2103	1705631	195
2104	1622446	185
2105	1543318	176
2106	1468050	167
2107	1396452	159
2108	1328347	152
2109	1263562	144
2110	1201938	137
2111	1143318	130
2112	1087558	124
2113	1034517	118
2114	984063	112
2115	936070	107

Year	Total LFG ¹	Total LFG Emission Rates at 50%v/v ² Methane
	m3/year	m3/h
2116	890417	102
2117	846991	97
2118	805683	92
2119	766389	87
2120	729012	83
2121	693458	79
2122	659637	75
2123	627466	72
2124	596865	68
2125	567755	65
2126	540065	62
2127	513726	59
2128	488671	56
2129	464839	53
2130	442168	50
2131	420603	48
2132	400090	46
2133	380578	43
2134	362017	41
2135	344361	39
2136	327566	37
2137	311591	36
2138	296394	34
2139	281939	32
2140	268189	31
2141	255109	29
2142	242667	28
2143	230832	26
2144	219574	25
2145	208865	24
2146	198679	23
2147	188989	22
2148	179772	21
2149	171005	20
2150	162665	19
2151	154731	18
2152	147185	17
2153	140007	16
2154	133178	15
2155	126683	14

Notes

- 1 Total landfill gas emitted calculated using LandGEM - Landfill Gas Emissions Model, Version 3.02
- 2 Hourly LFG emission rates estimated based on 365.25 days per year and 24 hours per day



Summary Report

Landfill Name or Identifier: Smooth Hill Landfill Gas Generation - 60Mgpa

Date: Wednesday, 26 May 2021

Description/Comments:

About LandGEM:

First-Order Decomposition Rate Equation:

$$Q_{CH_4} = \sum_{i=1}^n \sum_{j=0.1}^1 kL_o \left(\frac{M_i}{10} \right) e^{-kt_{ij}}$$

Where,

Q_{CH_4} = annual methane generation in the year of the calculation ($m^3/year$)

i = 1-year time increment

n = (year of the calculation) - (initial year of waste acceptance)

j = 0.1-year time increment

k = methane generation rate ($year^{-1}$)

L_o = potential methane generation capacity (m^3/Mg)

M_i = mass of waste accepted in the i^{th} year (Mg)

t_{ij} = age of the j^{th} section of waste mass M_i accepted in the i^{th} year (*decimal years*, e.g., 3.2 years)

LandGEM is based on a first-order decomposition rate equation for quantifying emissions from the decomposition of landfilled waste in municipal solid waste (MSW) landfills. The software provides a relatively simple approach to estimating landfill gas emissions. Model defaults are based on empirical data from U.S. landfills. Field test data can also be used in place of model defaults when available. Further guidance on EPA test methods, Clean Air Act (CAA) regulations, and other guidance regarding landfill gas emissions and control technology requirements can be found at <http://www.epa.gov/ttnatw01/landfill/landflpg.html>.

LandGEM is considered a screening tool — the better the input data, the better the estimates. Often, there are limitations with the available data regarding waste quantity and composition, variation in design and operating practices over time, and changes occurring over time that impact the emissions potential. Changes to landfill operation, such as operating under wet conditions through leachate recirculation or other liquid additions, will result in generating more gas at a faster rate. Defaults for estimating emissions for this type of operation are being developed to include in LandGEM along with defaults for conventional landfills (no leachate or liquid additions) for developing emission inventories and determining CAA applicability. Refer to the Web site identified above for future updates.

Input Review

LANDFILL CHARACTERISTICS

Landfill Open Year **2028**
 Landfill Closure Year (with 80-year limit) **2066**
 Actual Closure Year (without limit) **2066**
 Have Model Calculate Closure Year? **No**
 Waste Design Capacity **megagrams**

MODEL PARAMETERS

Methane Generation Rate, k **0.050** *year⁻¹*
 Potential Methane Generation Capacity, L₀ **100** *m³/Mg*
 NMOC Concentration **2,400** *ppmv as hexane*
 Methane Content **50** *% by volume*

GASES / POLLUTANTS SELECTED

Gas / Pollutant #1: **Total landfill gas**
 Gas / Pollutant #2: **Methane**
 Gas / Pollutant #3: **Carbon dioxide**
 Gas / Pollutant #4: **NMOC**

WASTE ACCEPTANCE RATES

Year	Waste Accepted		Waste-In-Place	
	(Mg/year)	(short tons/year)	(Mg)	(short tons)
2028	60,000	66,000	0	0
2029	60,000	66,000	60,000	66,000
2030	60,000	66,000	120,000	132,000
2031	60,000	66,000	180,000	198,000
2032	60,000	66,000	240,000	264,000
2033	60,000	66,000	300,000	330,000
2034	60,000	66,000	360,000	396,000
2035	60,000	66,000	420,000	462,000
2036	60,000	66,000	480,000	528,000
2037	60,000	66,000	540,000	594,000
2038	60,000	66,000	600,000	660,000
2039	60,000	66,000	660,000	726,000
2040	60,000	66,000	720,000	792,000
2041	60,000	66,000	780,000	858,000
2042	60,000	66,000	840,000	924,000
2043	60,000	66,000	900,000	990,000
2044	60,000	66,000	960,000	1,056,000
2045	60,000	66,000	1,020,000	1,122,000
2046	60,000	66,000	1,080,000	1,188,000
2047	60,000	66,000	1,140,000	1,254,000
2048	60,000	66,000	1,200,000	1,320,000
2049	60,000	66,000	1,260,000	1,386,000
2050	60,000	66,000	1,320,000	1,452,000
2051	60,000	66,000	1,380,000	1,518,000
2052	60,000	66,000	1,440,000	1,584,000
2053	60,000	66,000	1,500,000	1,650,000
2054	60,000	66,000	1,560,000	1,716,000
2055	60,000	66,000	1,620,000	1,782,000
2056	60,000	66,000	1,680,000	1,848,000
2057	60,000	66,000	1,740,000	1,914,000
2058	60,000	66,000	1,800,000	1,980,000
2059	60,000	66,000	1,860,000	2,046,000
2060	60,000	66,000	1,920,000	2,112,000
2061	60,000	66,000	1,980,000	2,178,000
2062	60,000	66,000	2,040,000	2,244,000
2063	60,000	66,000	2,100,000	2,310,000
2064	60,000	66,000	2,160,000	2,376,000
2065	60,000	66,000	2,220,000	2,442,000
2066	60,000	66,000	2,280,000	2,508,000
2067	0	0	2,340,000	2,574,000

WASTE ACCEPTANCE RATES (Continued)

Year	Waste Accepted		Waste-In-Place	
	(Mg/year)	(short tons/year)	(Mg)	(short tons)
2068	0	0	2,340,000	2,574,000
2069	0	0	2,340,000	2,574,000
2070	0	0	2,340,000	2,574,000
2071	0	0	2,340,000	2,574,000
2072	0	0	2,340,000	2,574,000
2073	0	0	2,340,000	2,574,000
2074	0	0	2,340,000	2,574,000
2075	0	0	2,340,000	2,574,000
2076	0	0	2,340,000	2,574,000
2077	0	0	2,340,000	2,574,000
2078	0	0	2,340,000	2,574,000
2079	0	0	2,340,000	2,574,000
2080	0	0	2,340,000	2,574,000
2081	0	0	2,340,000	2,574,000
2082	0	0	2,340,000	2,574,000
2083	0	0	2,340,000	2,574,000
2084	0	0	2,340,000	2,574,000
2085	0	0	2,340,000	2,574,000
2086	0	0	2,340,000	2,574,000
2087	0	0	2,340,000	2,574,000
2088	0	0	2,340,000	2,574,000
2089	0	0	2,340,000	2,574,000
2090	0	0	2,340,000	2,574,000
2091	0	0	2,340,000	2,574,000
2092	0	0	2,340,000	2,574,000
2093	0	0	2,340,000	2,574,000
2094	0	0	2,340,000	2,574,000
2095	0	0	2,340,000	2,574,000
2096	0	0	2,340,000	2,574,000
2097	0	0	2,340,000	2,574,000
2098	0	0	2,340,000	2,574,000
2099	0	0	2,340,000	2,574,000
2100	0	0	2,340,000	2,574,000
2101	0	0	2,340,000	2,574,000
2102	0	0	2,340,000	2,574,000
2103	0	0	2,340,000	2,574,000
2104	0	0	2,340,000	2,574,000
2105	0	0	2,340,000	2,574,000
2106	0	0	2,340,000	2,574,000
2107	0	0	2,340,000	2,574,000

Pollutant Parameters

Gas / Pollutant Default Parameters:				User-specified Pollutant Parameters:	
	Compound	Concentration (ppmv)	Molecular Weight	Concentration (ppmv)	Molecular Weight
Gases	Total landfill gas		0.00		
	Methane		16.04		
	Carbon dioxide		44.01		
	NMOC	4,000	86.18		
Pollutants	1,1,1-Trichloroethane (methyl chloroform) - HAP	0.48	133.41		
	1,1,1,2,2- Tetrachloroethane - HAP/VOC	1.1	167.85		
	1,1-Dichloroethane (ethylidene dichloride) - HAP/VOC	2.4	98.97		
	1,1-Dichloroethene (vinylidene chloride) - HAP/VOC	0.20	96.94		
	1,2-Dichloroethane (ethylene dichloride) - HAP/VOC	0.41	98.96		
	1,2-Dichloropropane (propylene dichloride) - HAP/VOC	0.18	112.99		
	2-Propanol (isopropyl alcohol) - VOC	50	60.11		
	Acetone	7.0	58.08		
	Acrylonitrile - HAP/VOC	6.3	53.06		
	Benzene - No or Unknown Co-disposal - HAP/VOC	1.9	78.11		
	Benzene - Co-disposal - HAP/VOC	11	78.11		
	Bromodichloromethane - VOC	3.1	163.83		
	Butane - VOC	5.0	58.12		
	Carbon disulfide - HAP/VOC	0.58	76.13		
	Carbon monoxide	140	28.01		
	Carbon tetrachloride - HAP/VOC	4.0E-03	153.84		
	Carbonyl sulfide - HAP/VOC	0.49	60.07		
	Chlorobenzene - HAP/VOC	0.25	112.56		
	Chlorodifluoromethane	1.3	86.47		
	Chloroethane (ethyl chloride) - HAP/VOC	1.3	64.52		
	Chloroform - HAP/VOC	0.03	119.39		
	Chloromethane - VOC	1.2	50.49		
	Dichlorobenzene - (HAP for para isomer/VOC)	0.21	147		
	Dichlorodifluoromethane	16	120.91		
	Dichlorofluoromethane - VOC	2.6	102.92		
	Dichloromethane (methylene chloride) - HAP	14	84.94		
	Dimethyl sulfide (methyl sulfide) - VOC	7.8	62.13		
	Ethane	890	30.07		
	Ethanol - VOC	27	46.08		

Graphs

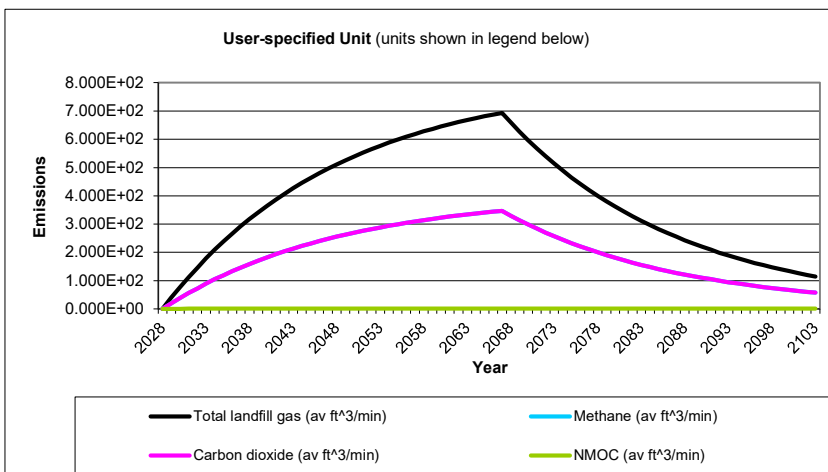
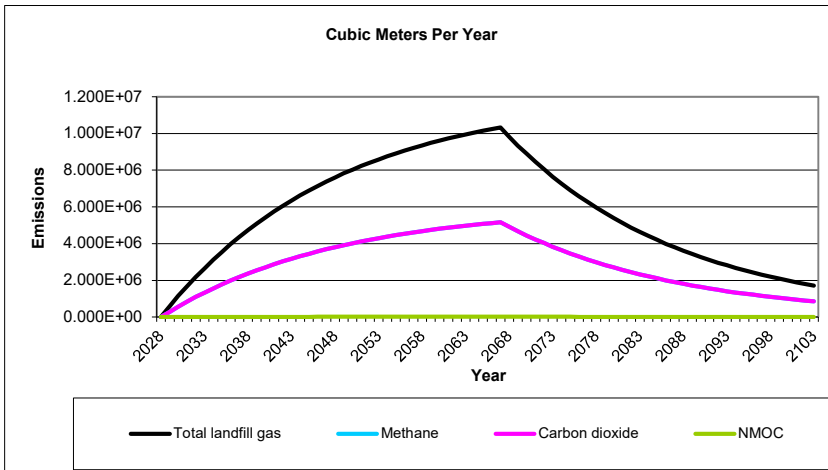
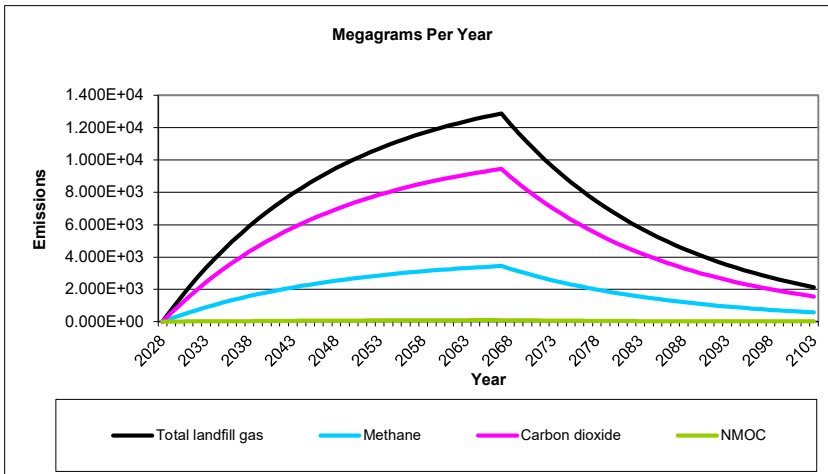

Results

Year	Total landfill gas			Methane		
	(Mg/year)	(m ³ /year)	(av ft ³ /min)	(Mg/year)	(m ³ /year)	(av ft ³ /min)
2028	0	0	0	0	0	0
2029	7.327E+02	5.867E+05	3.942E+01	1.957E+02	2.934E+05	1.971E+01
2030	1.430E+03	1.145E+06	7.692E+01	3.819E+02	5.724E+05	3.846E+01
2031	2.093E+03	1.676E+06	1.126E+02	5.590E+02	8.378E+05	5.629E+01
2032	2.723E+03	2.181E+06	1.465E+02	7.274E+02	1.090E+06	7.326E+01
2033	3.323E+03	2.661E+06	1.788E+02	8.877E+02	1.331E+06	8.940E+01
2034	3.894E+03	3.118E+06	2.095E+02	1.040E+03	1.559E+06	1.047E+02
2035	4.437E+03	3.553E+06	2.387E+02	1.185E+03	1.776E+06	1.193E+02
2036	4.953E+03	3.966E+06	2.665E+02	1.323E+03	1.983E+06	1.332E+02
2037	5.444E+03	4.359E+06	2.929E+02	1.454E+03	2.180E+06	1.465E+02
2038	5.911E+03	4.733E+06	3.180E+02	1.579E+03	2.367E+06	1.590E+02
2039	6.356E+03	5.089E+06	3.419E+02	1.698E+03	2.545E+06	1.710E+02
2040	6.778E+03	5.428E+06	3.647E+02	1.811E+03	2.714E+06	1.823E+02
2041	7.180E+03	5.750E+06	3.863E+02	1.918E+03	2.875E+06	1.932E+02
2042	7.563E+03	6.056E+06	4.069E+02	2.020E+03	3.028E+06	2.035E+02
2043	7.927E+03	6.347E+06	4.265E+02	2.117E+03	3.174E+06	2.132E+02
2044	8.273E+03	6.625E+06	4.451E+02	2.210E+03	3.312E+06	2.226E+02
2045	8.602E+03	6.888E+06	4.628E+02	2.298E+03	3.444E+06	2.314E+02
2046	8.915E+03	7.139E+06	4.797E+02	2.381E+03	3.569E+06	2.398E+02
2047	9.213E+03	7.378E+06	4.957E+02	2.461E+03	3.689E+06	2.478E+02
2048	9.497E+03	7.604E+06	5.109E+02	2.537E+03	3.802E+06	2.555E+02
2049	9.766E+03	7.820E+06	5.254E+02	2.609E+03	3.910E+06	2.627E+02
2050	1.002E+04	8.026E+06	5.392E+02	2.677E+03	4.013E+06	2.696E+02
2051	1.027E+04	8.221E+06	5.524E+02	2.742E+03	4.110E+06	2.762E+02
2052	1.050E+04	8.407E+06	5.648E+02	2.804E+03	4.203E+06	2.824E+02
2053	1.072E+04	8.583E+06	5.767E+02	2.863E+03	4.292E+06	2.884E+02
2054	1.093E+04	8.751E+06	5.880E+02	2.919E+03	4.376E+06	2.940E+02
2055	1.113E+04	8.911E+06	5.988E+02	2.973E+03	4.456E+06	2.994E+02
2056	1.132E+04	9.063E+06	6.090E+02	3.023E+03	4.532E+06	3.045E+02
2057	1.150E+04	9.208E+06	6.187E+02	3.072E+03	4.604E+06	3.093E+02
2058	1.167E+04	9.346E+06	6.279E+02	3.118E+03	4.673E+06	3.140E+02
2059	1.183E+04	9.477E+06	6.367E+02	3.161E+03	4.738E+06	3.184E+02
2060	1.199E+04	9.601E+06	6.451E+02	3.203E+03	4.801E+06	3.226E+02
2061	1.214E+04	9.720E+06	6.531E+02	3.242E+03	4.860E+06	3.265E+02
2062	1.228E+04	9.832E+06	6.606E+02	3.280E+03	4.916E+06	3.303E+02
2063	1.241E+04	9.940E+06	6.678E+02	3.316E+03	4.970E+06	3.339E+02
2064	1.254E+04	1.004E+07	6.747E+02	3.350E+03	5.021E+06	3.373E+02
2065	1.266E+04	1.014E+07	6.812E+02	3.382E+03	5.069E+06	3.406E+02
2066	1.278E+04	1.023E+07	6.874E+02	3.413E+03	5.115E+06	3.437E+02
2067	1.289E+04	1.032E+07	6.933E+02	3.442E+03	5.159E+06	3.466E+02
2068	1.226E+04	9.815E+06	6.595E+02	3.274E+03	4.908E+06	3.297E+02
2069	1.166E+04	9.337E+06	6.273E+02	3.114E+03	4.668E+06	3.137E+02
2070	1.109E+04	8.881E+06	5.967E+02	2.963E+03	4.441E+06	2.984E+02
2071	1.055E+04	8.448E+06	5.676E+02	2.818E+03	4.224E+06	2.838E+02
2072	1.004E+04	8.036E+06	5.399E+02	2.681E+03	4.018E+06	2.700E+02
2073	9.546E+03	7.644E+06	5.136E+02	2.550E+03	3.822E+06	2.568E+02
2074	9.081E+03	7.271E+06	4.886E+02	2.426E+03	3.636E+06	2.443E+02
2075	8.638E+03	6.917E+06	4.647E+02	2.307E+03	3.458E+06	2.324E+02
2076	8.216E+03	6.579E+06	4.421E+02	2.195E+03	3.290E+06	2.210E+02
2077	7.816E+03	6.258E+06	4.205E+02	2.088E+03	3.129E+06	2.103E+02

Results (Continued)

Year	Total landfill gas			Methane		
	(Mg/year)	(m ³ /year)	(av ft ³ /min)	(Mg/year)	(m ³ /year)	(av ft ³ /min)
2078	7.435E+03	5.953E+06	4.000E+02	1.986E+03	2.977E+06	2.000E+02
2079	7.072E+03	5.663E+06	3.805E+02	1.889E+03	2.831E+06	1.902E+02
2080	6.727E+03	5.387E+06	3.619E+02	1.797E+03	2.693E+06	1.810E+02
2081	6.399E+03	5.124E+06	3.443E+02	1.709E+03	2.562E+06	1.721E+02
2082	6.087E+03	4.874E+06	3.275E+02	1.626E+03	2.437E+06	1.637E+02
2083	5.790E+03	4.636E+06	3.115E+02	1.547E+03	2.318E+06	1.558E+02
2084	5.508E+03	4.410E+06	2.963E+02	1.471E+03	2.205E+06	1.482E+02
2085	5.239E+03	4.195E+06	2.819E+02	1.399E+03	2.098E+06	1.409E+02
2086	4.984E+03	3.991E+06	2.681E+02	1.331E+03	1.995E+06	1.341E+02
2087	4.740E+03	3.796E+06	2.550E+02	1.266E+03	1.898E+06	1.275E+02
2088	4.509E+03	3.611E+06	2.426E+02	1.204E+03	1.805E+06	1.213E+02
2089	4.289E+03	3.435E+06	2.308E+02	1.146E+03	1.717E+06	1.154E+02
2090	4.080E+03	3.267E+06	2.195E+02	1.090E+03	1.634E+06	1.098E+02
2091	3.881E+03	3.108E+06	2.088E+02	1.037E+03	1.554E+06	1.044E+02
2092	3.692E+03	2.956E+06	1.986E+02	9.861E+02	1.478E+06	9.932E+01
2093	3.512E+03	2.812E+06	1.889E+02	9.380E+02	1.406E+06	9.447E+01
2094	3.341E+03	2.675E+06	1.797E+02	8.923E+02	1.337E+06	8.987E+01
2095	3.178E+03	2.545E+06	1.710E+02	8.488E+02	1.272E+06	8.548E+01
2096	3.023E+03	2.420E+06	1.626E+02	8.074E+02	1.210E+06	8.131E+01
2097	2.875E+03	2.302E+06	1.547E+02	7.680E+02	1.151E+06	7.735E+01
2098	2.735E+03	2.190E+06	1.472E+02	7.306E+02	1.095E+06	7.358E+01
2099	2.602E+03	2.083E+06	1.400E+02	6.949E+02	1.042E+06	6.999E+01
2100	2.475E+03	1.982E+06	1.331E+02	6.610E+02	9.908E+05	6.657E+01
2101	2.354E+03	1.885E+06	1.267E+02	6.288E+02	9.425E+05	6.333E+01
2102	2.239E+03	1.793E+06	1.205E+02	5.981E+02	8.965E+05	6.024E+01
2103	2.130E+03	1.706E+06	1.146E+02	5.690E+02	8.528E+05	5.730E+01
2104	2.026E+03	1.622E+06	1.090E+02	5.412E+02	8.112E+05	5.451E+01
2105	1.927E+03	1.543E+06	1.037E+02	5.148E+02	7.717E+05	5.185E+01
2106	1.833E+03	1.468E+06	9.864E+01	4.897E+02	7.340E+05	4.932E+01
2107	1.744E+03	1.396E+06	9.383E+01	4.658E+02	6.982E+05	4.691E+01
2108	1.659E+03	1.328E+06	8.925E+01	4.431E+02	6.642E+05	4.463E+01
2109	1.578E+03	1.264E+06	8.490E+01	4.215E+02	6.318E+05	4.245E+01
2110	1.501E+03	1.202E+06	8.076E+01	4.009E+02	6.010E+05	4.038E+01
2111	1.428E+03	1.143E+06	7.682E+01	3.814E+02	5.717E+05	3.841E+01
2112	1.358E+03	1.088E+06	7.307E+01	3.628E+02	5.438E+05	3.654E+01
2113	1.292E+03	1.035E+06	6.951E+01	3.451E+02	5.173E+05	3.475E+01
2114	1.229E+03	9.841E+05	6.612E+01	3.283E+02	4.920E+05	3.306E+01
2115	1.169E+03	9.361E+05	6.289E+01	3.122E+02	4.680E+05	3.145E+01
2116	1.112E+03	8.904E+05	5.983E+01	2.970E+02	4.452E+05	2.991E+01
2117	1.058E+03	8.470E+05	5.691E+01	2.825E+02	4.235E+05	2.845E+01
2118	1.006E+03	8.057E+05	5.413E+01	2.688E+02	4.028E+05	2.707E+01
2119	9.571E+02	7.664E+05	5.149E+01	2.556E+02	3.832E+05	2.575E+01
2120	9.104E+02	7.290E+05	4.898E+01	2.432E+02	3.645E+05	2.449E+01
2121	8.660E+02	6.935E+05	4.659E+01	2.313E+02	3.467E+05	2.330E+01
2122	8.238E+02	6.596E+05	4.432E+01	2.200E+02	3.298E+05	2.216E+01
2123	7.836E+02	6.275E+05	4.216E+01	2.093E+02	3.137E+05	2.108E+01
2124	7.454E+02	5.969E+05	4.010E+01	1.991E+02	2.984E+05	2.005E+01
2125	7.090E+02	5.678E+05	3.815E+01	1.894E+02	2.839E+05	1.907E+01
2126	6.744E+02	5.401E+05	3.629E+01	1.802E+02	2.700E+05	1.814E+01
2127	6.416E+02	5.137E+05	3.452E+01	1.714E+02	2.569E+05	1.726E+01
2128	6.103E+02	4.887E+05	3.283E+01	1.630E+02	2.443E+05	1.642E+01

Results (Continued)

Year	Total landfill gas			Methane		
	(Mg/year)	(m ³ /year)	(av ft ³ /min)	(Mg/year)	(m ³ /year)	(av ft ³ /min)
2129	5.805E+02	4.648E+05	3.123E+01	1.551E+02	2.324E+05	1.562E+01
2130	5.522E+02	4.422E+05	2.971E+01	1.475E+02	2.211E+05	1.485E+01
2131	5.253E+02	4.206E+05	2.826E+01	1.403E+02	2.103E+05	1.413E+01
2132	4.996E+02	4.001E+05	2.688E+01	1.335E+02	2.000E+05	1.344E+01
2133	4.753E+02	3.806E+05	2.557E+01	1.270E+02	1.903E+05	1.279E+01
2134	4.521E+02	3.620E+05	2.432E+01	1.208E+02	1.810E+05	1.216E+01
2135	4.300E+02	3.444E+05	2.314E+01	1.149E+02	1.722E+05	1.157E+01
2136	4.091E+02	3.276E+05	2.201E+01	1.093E+02	1.638E+05	1.100E+01
2137	3.891E+02	3.116E+05	2.094E+01	1.039E+02	1.558E+05	1.047E+01
2138	3.701E+02	2.964E+05	1.991E+01	9.887E+01	1.482E+05	9.957E+00
2139	3.521E+02	2.819E+05	1.894E+01	9.405E+01	1.410E+05	9.472E+00
2140	3.349E+02	2.682E+05	1.802E+01	8.946E+01	1.341E+05	9.010E+00
2141	3.186E+02	2.551E+05	1.714E+01	8.510E+01	1.276E+05	8.570E+00
2142	3.030E+02	2.427E+05	1.630E+01	8.095E+01	1.213E+05	8.152E+00
2143	2.883E+02	2.308E+05	1.551E+01	7.700E+01	1.154E+05	7.755E+00
2144	2.742E+02	2.196E+05	1.475E+01	7.324E+01	1.098E+05	7.377E+00
2145	2.608E+02	2.089E+05	1.403E+01	6.967E+01	1.044E+05	7.017E+00
2146	2.481E+02	1.987E+05	1.335E+01	6.627E+01	9.934E+04	6.675E+00
2147	2.360E+02	1.890E+05	1.270E+01	6.304E+01	9.449E+04	6.349E+00
2148	2.245E+02	1.798E+05	1.208E+01	5.997E+01	8.989E+04	6.039E+00
2149	2.136E+02	1.710E+05	1.149E+01	5.704E+01	8.550E+04	5.745E+00
2150	2.031E+02	1.627E+05	1.093E+01	5.426E+01	8.133E+04	5.465E+00
2151	1.932E+02	1.547E+05	1.040E+01	5.161E+01	7.737E+04	5.198E+00
2152	1.838E+02	1.472E+05	9.889E+00	4.910E+01	7.359E+04	4.945E+00
2153	1.748E+02	1.400E+05	9.407E+00	4.670E+01	7.000E+04	4.704E+00
2154	1.663E+02	1.332E+05	8.948E+00	4.442E+01	6.659E+04	4.474E+00
2155	1.582E+02	1.267E+05	8.512E+00	4.226E+01	6.334E+04	4.256E+00
2156	1.505E+02	1.205E+05	8.097E+00	4.020E+01	6.025E+04	4.048E+00
2157	1.431E+02	1.146E+05	7.702E+00	3.824E+01	5.731E+04	3.851E+00
2158	1.362E+02	1.090E+05	7.326E+00	3.637E+01	5.452E+04	3.663E+00
2159	1.295E+02	1.037E+05	6.969E+00	3.460E+01	5.186E+04	3.484E+00
2160	1.232E+02	9.866E+04	6.629E+00	3.291E+01	4.933E+04	3.315E+00
2161	1.172E+02	9.385E+04	6.306E+00	3.131E+01	4.692E+04	3.153E+00
2162	1.115E+02	8.927E+04	5.998E+00	2.978E+01	4.464E+04	2.999E+00
2163	1.060E+02	8.492E+04	5.706E+00	2.833E+01	4.246E+04	2.853E+00
2164	1.009E+02	8.078E+04	5.427E+00	2.695E+01	4.039E+04	2.714E+00
2165	9.596E+01	7.684E+04	5.163E+00	2.563E+01	3.842E+04	2.581E+00
2166	9.128E+01	7.309E+04	4.911E+00	2.438E+01	3.654E+04	2.455E+00
2167	8.682E+01	6.953E+04	4.671E+00	2.319E+01	3.476E+04	2.336E+00
2168	8.259E+01	6.613E+04	4.444E+00	2.206E+01	3.307E+04	2.222E+00

Results (Continued)

Year	Carbon dioxide			NMOC		
	(Mg/year)	(m ³ /year)	(av ft ³ /min)	(Mg/year)	(m ³ /year)	(av ft ³ /min)
2028	0	0	0	0	0	0
2029	5.370E+02	2.934E+05	1.971E+01	5.047E+00	1.408E+03	9.461E-02
2030	1.048E+03	5.724E+05	3.846E+01	9.848E+00	2.748E+03	1.846E-01
2031	1.534E+03	8.378E+05	5.629E+01	1.442E+01	4.022E+03	2.702E-01
2032	1.996E+03	1.090E+06	7.326E+01	1.876E+01	5.234E+03	3.516E-01
2033	2.436E+03	1.331E+06	8.940E+01	2.289E+01	6.386E+03	4.291E-01
2034	2.854E+03	1.559E+06	1.047E+02	2.682E+01	7.483E+03	5.028E-01
2035	3.252E+03	1.776E+06	1.193E+02	3.056E+01	8.526E+03	5.729E-01
2036	3.630E+03	1.983E+06	1.332E+02	3.412E+01	9.519E+03	6.395E-01
2037	3.990E+03	2.180E+06	1.465E+02	3.750E+01	1.046E+04	7.030E-01
2038	4.332E+03	2.367E+06	1.590E+02	4.072E+01	1.136E+04	7.633E-01
2039	4.658E+03	2.545E+06	1.710E+02	4.378E+01	1.221E+04	8.207E-01
2040	4.968E+03	2.714E+06	1.823E+02	4.669E+01	1.303E+04	8.753E-01
2041	5.263E+03	2.875E+06	1.932E+02	4.946E+01	1.380E+04	9.272E-01
2042	5.543E+03	3.028E+06	2.035E+02	5.210E+01	1.453E+04	9.766E-01
2043	5.809E+03	3.174E+06	2.132E+02	5.461E+01	1.523E+04	1.024E+00
2044	6.063E+03	3.312E+06	2.226E+02	5.699E+01	1.590E+04	1.068E+00
2045	6.304E+03	3.444E+06	2.314E+02	5.926E+01	1.653E+04	1.111E+00
2046	6.534E+03	3.569E+06	2.398E+02	6.141E+01	1.713E+04	1.151E+00
2047	6.752E+03	3.689E+06	2.478E+02	6.347E+01	1.771E+04	1.190E+00
2048	6.960E+03	3.802E+06	2.555E+02	6.542E+01	1.825E+04	1.226E+00
2049	7.157E+03	3.910E+06	2.627E+02	6.728E+01	1.877E+04	1.261E+00
2050	7.345E+03	4.013E+06	2.696E+02	6.904E+01	1.926E+04	1.294E+00
2051	7.524E+03	4.110E+06	2.762E+02	7.072E+01	1.973E+04	1.326E+00
2052	7.694E+03	4.203E+06	2.824E+02	7.232E+01	2.018E+04	1.356E+00
2053	7.856E+03	4.292E+06	2.884E+02	7.384E+01	2.060E+04	1.384E+00
2054	8.010E+03	4.376E+06	2.940E+02	7.529E+01	2.100E+04	1.411E+00
2055	8.156E+03	4.456E+06	2.994E+02	7.666E+01	2.139E+04	1.437E+00
2056	8.295E+03	4.532E+06	3.045E+02	7.797E+01	2.175E+04	1.462E+00
2057	8.428E+03	4.604E+06	3.093E+02	7.922E+01	2.210E+04	1.485E+00
2058	8.554E+03	4.673E+06	3.140E+02	8.040E+01	2.243E+04	1.507E+00
2059	8.674E+03	4.738E+06	3.184E+02	8.153E+01	2.274E+04	1.528E+00
2060	8.787E+03	4.801E+06	3.226E+02	8.260E+01	2.304E+04	1.548E+00
2061	8.896E+03	4.860E+06	3.265E+02	8.362E+01	2.333E+04	1.567E+00
2062	8.999E+03	4.916E+06	3.303E+02	8.458E+01	2.360E+04	1.586E+00
2063	9.097E+03	4.970E+06	3.339E+02	8.551E+01	2.385E+04	1.603E+00
2064	9.190E+03	5.021E+06	3.373E+02	8.638E+01	2.410E+04	1.619E+00
2065	9.279E+03	5.069E+06	3.406E+02	8.722E+01	2.433E+04	1.635E+00
2066	9.364E+03	5.115E+06	3.437E+02	8.801E+01	2.455E+04	1.650E+00
2067	9.444E+03	5.159E+06	3.466E+02	8.877E+01	2.476E+04	1.664E+00
2068	8.983E+03	4.908E+06	3.297E+02	8.444E+01	2.356E+04	1.583E+00
2069	8.545E+03	4.668E+06	3.137E+02	8.032E+01	2.241E+04	1.506E+00
2070	8.128E+03	4.441E+06	2.984E+02	7.640E+01	2.131E+04	1.432E+00
2071	7.732E+03	4.224E+06	2.838E+02	7.268E+01	2.028E+04	1.362E+00
2072	7.355E+03	4.018E+06	2.700E+02	6.913E+01	1.929E+04	1.296E+00
2073	6.996E+03	3.822E+06	2.568E+02	6.576E+01	1.835E+04	1.233E+00
2074	6.655E+03	3.636E+06	2.443E+02	6.255E+01	1.745E+04	1.173E+00
2075	6.330E+03	3.458E+06	2.324E+02	5.950E+01	1.660E+04	1.115E+00
2076	6.022E+03	3.290E+06	2.210E+02	5.660E+01	1.579E+04	1.061E+00
2077	5.728E+03	3.129E+06	2.103E+02	5.384E+01	1.502E+04	1.009E+00

Results (Continued)

Year	Carbon dioxide			NMOC		
	(Mg/year)	(m ³ /year)	(av ft ³ /min)	(Mg/year)	(m ³ /year)	(av ft ³ /min)
2078	5.449E+03	2.977E+06	2.000E+02	5.121E+01	1.429E+04	9.600E-01
2079	5.183E+03	2.831E+06	1.902E+02	4.872E+01	1.359E+04	9.132E-01
2080	4.930E+03	2.693E+06	1.810E+02	4.634E+01	1.293E+04	8.686E-01
2081	4.690E+03	2.562E+06	1.721E+02	4.408E+01	1.230E+04	8.263E-01
2082	4.461E+03	2.437E+06	1.637E+02	4.193E+01	1.170E+04	7.860E-01
2083	4.243E+03	2.318E+06	1.558E+02	3.989E+01	1.113E+04	7.476E-01
2084	4.036E+03	2.205E+06	1.482E+02	3.794E+01	1.058E+04	7.112E-01
2085	3.840E+03	2.098E+06	1.409E+02	3.609E+01	1.007E+04	6.765E-01
2086	3.652E+03	1.995E+06	1.341E+02	3.433E+01	9.577E+03	6.435E-01
2087	3.474E+03	1.898E+06	1.275E+02	3.266E+01	9.110E+03	6.121E-01
2088	3.305E+03	1.805E+06	1.213E+02	3.106E+01	8.666E+03	5.823E-01
2089	3.144E+03	1.717E+06	1.154E+02	2.955E+01	8.243E+03	5.539E-01
2090	2.990E+03	1.634E+06	1.098E+02	2.811E+01	7.841E+03	5.269E-01
2091	2.844E+03	1.554E+06	1.044E+02	2.674E+01	7.459E+03	5.012E-01
2092	2.706E+03	1.478E+06	9.932E+01	2.543E+01	7.095E+03	4.767E-01
2093	2.574E+03	1.406E+06	9.447E+01	2.419E+01	6.749E+03	4.535E-01
2094	2.448E+03	1.337E+06	8.987E+01	2.301E+01	6.420E+03	4.314E-01
2095	2.329E+03	1.272E+06	8.548E+01	2.189E+01	6.107E+03	4.103E-01
2096	2.215E+03	1.210E+06	8.131E+01	2.082E+01	5.809E+03	3.903E-01
2097	2.107E+03	1.151E+06	7.735E+01	1.981E+01	5.526E+03	3.713E-01
2098	2.004E+03	1.095E+06	7.358E+01	1.884E+01	5.256E+03	3.532E-01
2099	1.907E+03	1.042E+06	6.999E+01	1.792E+01	5.000E+03	3.359E-01
2100	1.814E+03	9.908E+05	6.657E+01	1.705E+01	4.756E+03	3.196E-01
2101	1.725E+03	9.425E+05	6.333E+01	1.622E+01	4.524E+03	3.040E-01
2102	1.641E+03	8.965E+05	6.024E+01	1.543E+01	4.303E+03	2.891E-01
2103	1.561E+03	8.528E+05	5.730E+01	1.467E+01	4.094E+03	2.750E-01
2104	1.485E+03	8.112E+05	5.451E+01	1.396E+01	3.894E+03	2.616E-01
2105	1.413E+03	7.717E+05	5.185E+01	1.328E+01	3.704E+03	2.489E-01
2106	1.344E+03	7.340E+05	4.932E+01	1.263E+01	3.523E+03	2.367E-01
2107	1.278E+03	6.982E+05	4.691E+01	1.201E+01	3.351E+03	2.252E-01
2108	1.216E+03	6.642E+05	4.463E+01	1.143E+01	3.188E+03	2.142E-01
2109	1.156E+03	6.318E+05	4.245E+01	1.087E+01	3.033E+03	2.038E-01
2110	1.100E+03	6.010E+05	4.038E+01	1.034E+01	2.885E+03	1.938E-01
2111	1.046E+03	5.717E+05	3.841E+01	9.836E+00	2.744E+03	1.844E-01
2112	9.954E+02	5.438E+05	3.654E+01	9.356E+00	2.610E+03	1.754E-01
2113	9.468E+02	5.173E+05	3.475E+01	8.900E+00	2.483E+03	1.668E-01
2114	9.007E+02	4.920E+05	3.306E+01	8.466E+00	2.362E+03	1.587E-01
2115	8.567E+02	4.680E+05	3.145E+01	8.053E+00	2.247E+03	1.509E-01
2116	8.150E+02	4.452E+05	2.991E+01	7.660E+00	2.137E+03	1.436E-01
2117	7.752E+02	4.235E+05	2.845E+01	7.286E+00	2.033E+03	1.366E-01
2118	7.374E+02	4.028E+05	2.707E+01	6.931E+00	1.934E+03	1.299E-01
2119	7.014E+02	3.832E+05	2.575E+01	6.593E+00	1.839E+03	1.236E-01
2120	6.672E+02	3.645E+05	2.449E+01	6.271E+00	1.750E+03	1.176E-01
2121	6.347E+02	3.467E+05	2.330E+01	5.966E+00	1.664E+03	1.118E-01
2122	6.037E+02	3.298E+05	2.216E+01	5.675E+00	1.583E+03	1.064E-01
2123	5.743E+02	3.137E+05	2.108E+01	5.398E+00	1.506E+03	1.012E-01
2124	5.463E+02	2.984E+05	2.005E+01	5.135E+00	1.432E+03	9.625E-02
2125	5.196E+02	2.839E+05	1.907E+01	4.884E+00	1.363E+03	9.155E-02
2126	4.943E+02	2.700E+05	1.814E+01	4.646E+00	1.296E+03	8.709E-02
2127	4.702E+02	2.569E+05	1.726E+01	4.419E+00	1.233E+03	8.284E-02
2128	4.473E+02	2.443E+05	1.642E+01	4.204E+00	1.173E+03	7.880E-02

Results (Continued)

Year	Carbon dioxide			NMOC		
	(Mg/year)	(m ³ /year)	(av ft ³ /min)	(Mg/year)	(m ³ /year)	(av ft ³ /min)
2129	4.254E+02	2.324E+05	1.562E+01	3.999E+00	1.116E+03	7.496E-02
2130	4.047E+02	2.211E+05	1.485E+01	3.804E+00	1.061E+03	7.130E-02
2131	3.850E+02	2.103E+05	1.413E+01	3.618E+00	1.009E+03	6.782E-02
2132	3.662E+02	2.000E+05	1.344E+01	3.442E+00	9.602E+02	6.452E-02
2133	3.483E+02	1.903E+05	1.279E+01	3.274E+00	9.134E+02	6.137E-02
2134	3.313E+02	1.810E+05	1.216E+01	3.114E+00	8.688E+02	5.838E-02
2135	3.152E+02	1.722E+05	1.157E+01	2.962E+00	8.265E+02	5.553E-02
2136	2.998E+02	1.638E+05	1.100E+01	2.818E+00	7.862E+02	5.282E-02
2137	2.852E+02	1.558E+05	1.047E+01	2.681E+00	7.478E+02	5.025E-02
2138	2.713E+02	1.482E+05	9.957E+00	2.550E+00	7.113E+02	4.780E-02
2139	2.580E+02	1.410E+05	9.472E+00	2.425E+00	6.767E+02	4.546E-02
2140	2.455E+02	1.341E+05	9.010E+00	2.307E+00	6.437E+02	4.325E-02
2141	2.335E+02	1.276E+05	8.570E+00	2.195E+00	6.123E+02	4.114E-02
2142	2.221E+02	1.213E+05	8.152E+00	2.088E+00	5.824E+02	3.913E-02
2143	2.113E+02	1.154E+05	7.755E+00	1.986E+00	5.540E+02	3.722E-02
2144	2.010E+02	1.098E+05	7.377E+00	1.889E+00	5.270E+02	3.541E-02
2145	1.912E+02	1.044E+05	7.017E+00	1.797E+00	5.013E+02	3.368E-02
2146	1.818E+02	9.934E+04	6.675E+00	1.709E+00	4.768E+02	3.204E-02
2147	1.730E+02	9.449E+04	6.349E+00	1.626E+00	4.536E+02	3.048E-02
2148	1.645E+02	8.989E+04	6.039E+00	1.547E+00	4.315E+02	2.899E-02
2149	1.565E+02	8.550E+04	5.745E+00	1.471E+00	4.104E+02	2.758E-02
2150	1.489E+02	8.133E+04	5.465E+00	1.399E+00	3.904E+02	2.623E-02
2151	1.416E+02	7.737E+04	5.198E+00	1.331E+00	3.714E+02	2.495E-02
2152	1.347E+02	7.359E+04	4.945E+00	1.266E+00	3.532E+02	2.373E-02
2153	1.281E+02	7.000E+04	4.704E+00	1.204E+00	3.360E+02	2.258E-02
2154	1.219E+02	6.659E+04	4.474E+00	1.146E+00	3.196E+02	2.148E-02
2155	1.159E+02	6.334E+04	4.256E+00	1.090E+00	3.040E+02	2.043E-02
2156	1.103E+02	6.025E+04	4.048E+00	1.037E+00	2.892E+02	1.943E-02
2157	1.049E+02	5.731E+04	3.851E+00	9.861E-01	2.751E+02	1.848E-02
2158	9.980E+01	5.452E+04	3.663E+00	9.380E-01	2.617E+02	1.758E-02
2159	9.493E+01	5.186E+04	3.484E+00	8.923E-01	2.489E+02	1.673E-02
2160	9.030E+01	4.933E+04	3.315E+00	8.488E-01	2.368E+02	1.591E-02
2161	8.590E+01	4.692E+04	3.153E+00	8.074E-01	2.252E+02	1.513E-02
2162	8.171E+01	4.464E+04	2.999E+00	7.680E-01	2.143E+02	1.440E-02
2163	7.772E+01	4.246E+04	2.853E+00	7.305E-01	2.038E+02	1.369E-02
2164	7.393E+01	4.039E+04	2.714E+00	6.949E-01	1.939E+02	1.303E-02
2165	7.033E+01	3.842E+04	2.581E+00	6.610E-01	1.844E+02	1.239E-02
2166	6.690E+01	3.654E+04	2.455E+00	6.288E-01	1.754E+02	1.179E-02
2167	6.363E+01	3.476E+04	2.336E+00	5.981E-01	1.669E+02	1.121E-02
2168	6.053E+01	3.307E+04	2.222E+00	5.689E-01	1.587E+02	1.066E-02

Appendix C – Conceptual Site Models

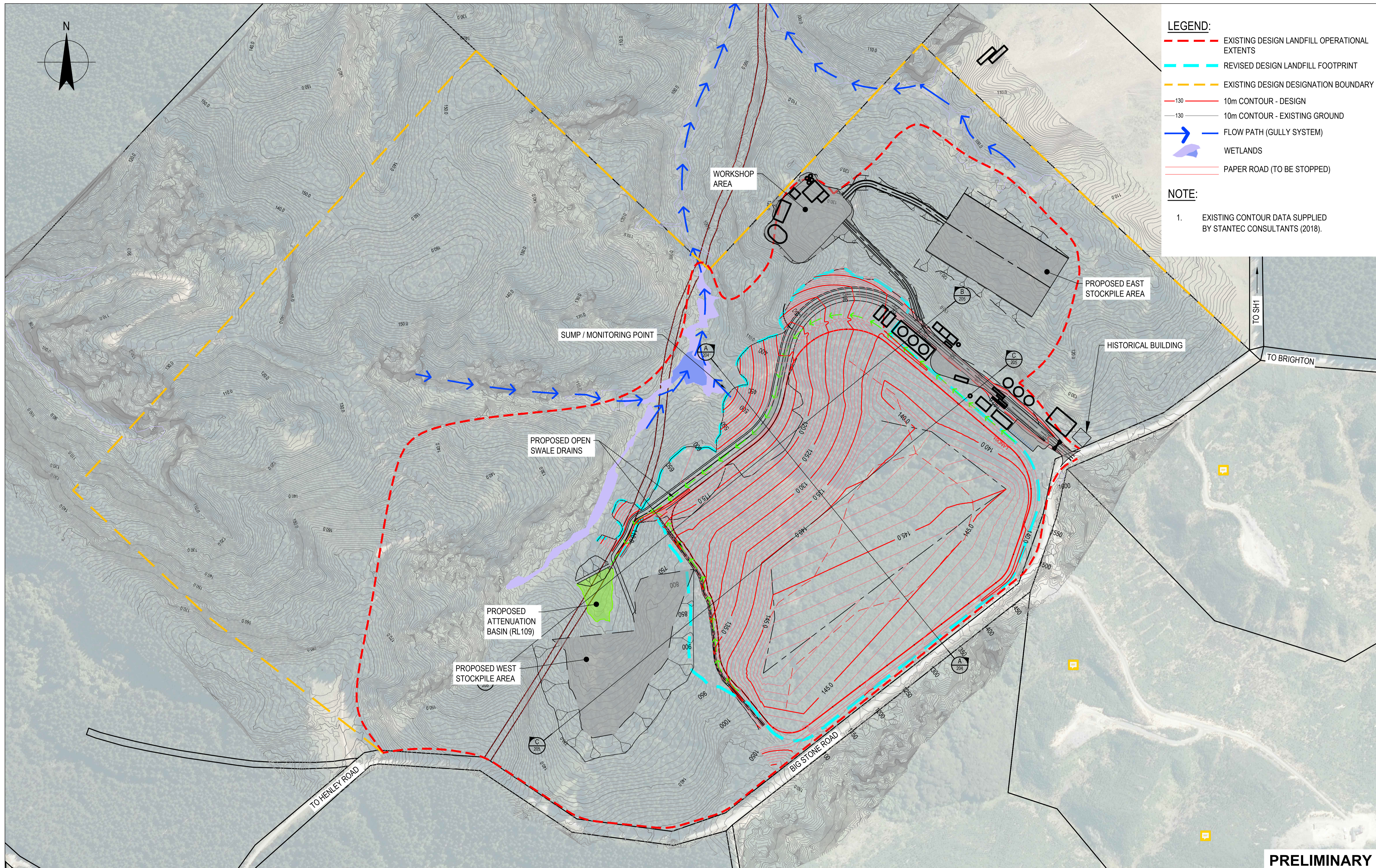

- LEGEND:**
- - - EXISTING DESIGN LANDFILL OPERATIONAL EXTENTS
 - - - REVISED DESIGN LANDFILL FOOTPRINT
 - - - EXISTING DESIGN DESIGNATION BOUNDARY
 - 130 10m CONTOUR - DESIGN
 - 130 10m CONTOUR - EXISTING GROUND
 - FLOW PATH (GULLY SYSTEM)
 - WETLANDS
 - PAPER ROAD (TO BE STOPPED)

NOTE:

1. EXISTING CONTOUR DATA SUPPLIED BY STANTEC CONSULTANTS (2018).

PRELIMINARY

No	Revision	Note: * indicates signatures on original issue of drawing or last revision of drawing	Drawn	Job Manager	Project Director	Date
A	PRELIMINARY		PK			

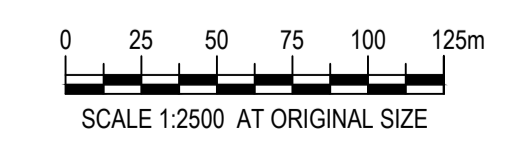

GHD

DRAFT
08/03/2021

Level 2, 67-69 Albert Square, Palmerston North, New Zealand
 P O Box 67, Palmerston North, Auckland 1011 New Zealand
 T 64 6 383 8800 F 64 6 383 8801
 E plm@ghd.com www.ghd.com

DO NOT SCALE

Drawn	Designer
Drafting Check	Design Check
Approved (Project Director)	Date
Scale AS SHOWN	This Drawing must not be used for Construction unless signed as Approved

Client	DUNEDIN CITY COUNCIL
Project	SMOOTH HILL LANDFILL
Title	DESIGN CAP AND EXISTING CONTOURS
	REVISION 2 DESIGN
Original Size	A1
Drawing No:	51-12506381-01-SK600
Rev:	A

Appendix D – Concept design drawings of LFG collection and treatment/destruction system

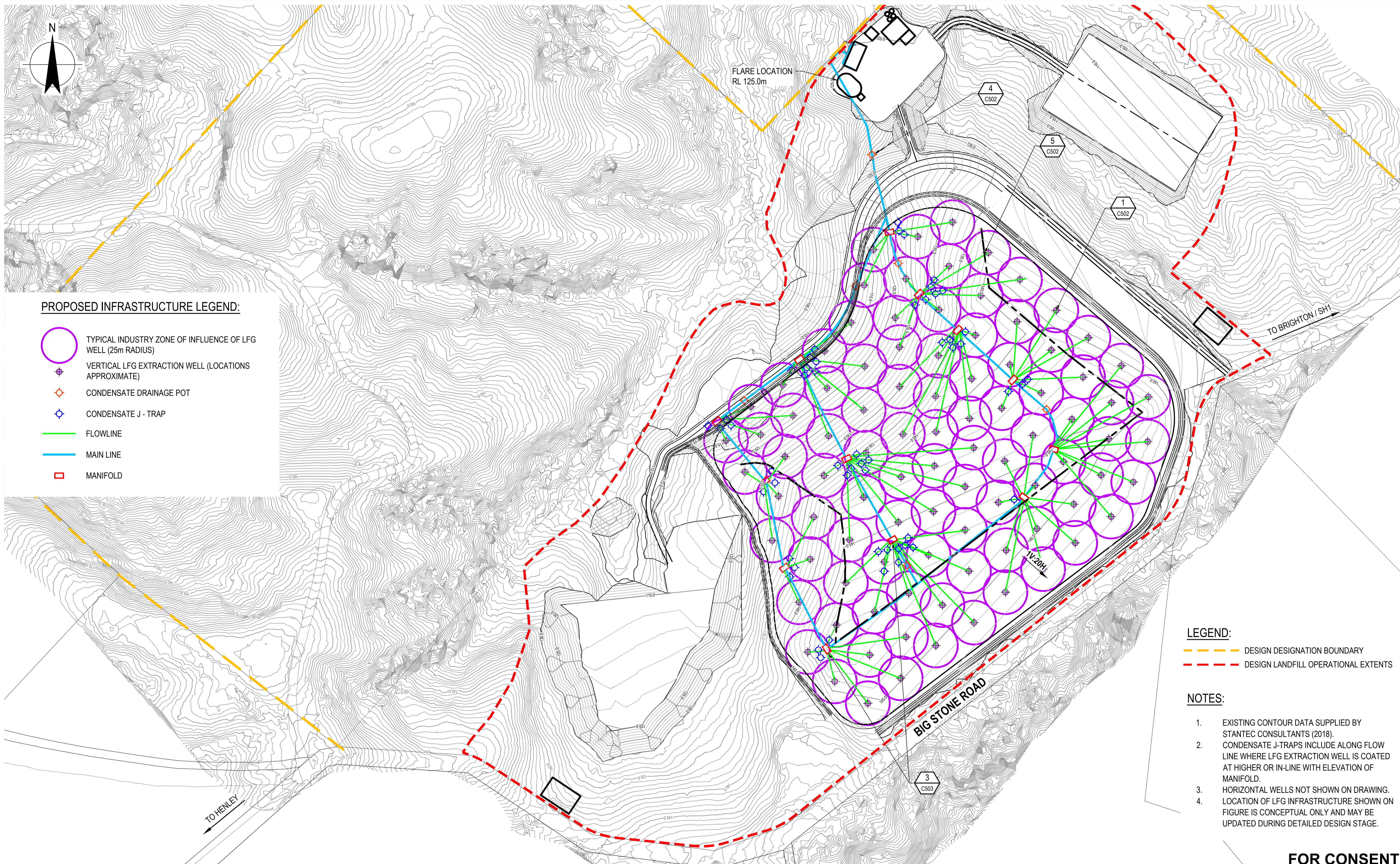

PROPOSED INFRASTRUCTURE LEGEND:

- TYPICAL INDUSTRY ZONE OF INFLUENCE OF LFG WELL (25m RADIUS)
- ⊕ VERTICAL LFG EXTRACTION WELL (LOCATIONS APPROXIMATE)
- ◇ CONDENSATE DRAINAGE POT
- ◇ CONDENSATE J - TRAP
- FLOWLINE
- MAIN LINE
- MANIFOLD

LEGEND:

- - - DESIGN DESIGNATION BOUNDARY
- - - DESIGN LANDFILL OPERATIONAL EXTENTS

NOTES:

1. EXISTING CONTOUR DATA SUPPLIED BY STANTEC CONSULTANTS (2018).
2. CONDENSATE J-TRAPS INCLUDE ALONG FLOW LINE WHERE LFG EXTRACTION WELL IS COATED AT HIGHER OR IN-LINE WITH ELEVATION OF MANIFOLD.
3. HORIZONTAL WELLS NOT SHOWN ON DRAWING.
4. LOCATION OF LFG INFRASTRUCTURE SHOWN ON FIGURE IS CONCEPTUAL ONLY AND MAY BE UPDATED DURING DETAILED DESIGN STAGE.

**FOR CONSENT
NOT FOR CONSTRUCTION**

No	Revision	Note	Drawn	Job Manager	Project Director	Date
2	RE-ISSUE FOR CONSENT		RG	NE*	SD*	21.05.21
1	FOR CONSENT		SLP	NE*	SD*	14.08.20



DO NOT SCALE
GHD Pty Ltd
Conditions of Use.
This document may only be used by GHD's client (and any other person who GHD has agreed can use this document) for the purpose for which it was prepared and must not be used by any other person or for any other purpose.

Drawn	R. GERONIMO	Designer	M. WELSH
Drafting Check	G. DOUGHERTY*	Design Check	N. ELDRED*
Approved (Project Director)	S. DOUGLASS*		
Date	14.08.20		
Scale	1 : 2000		

Client	DUNEDIN CITY COUNCIL		
Project	SMOOTH HILL LANDFILL		
Title	LANDFILL GAS MANAGEMENT CONCEPTUAL SYSTEM LAYOUT		
Original Size	A1	Drawing No:	12506381-01-C501
		Rev:	2

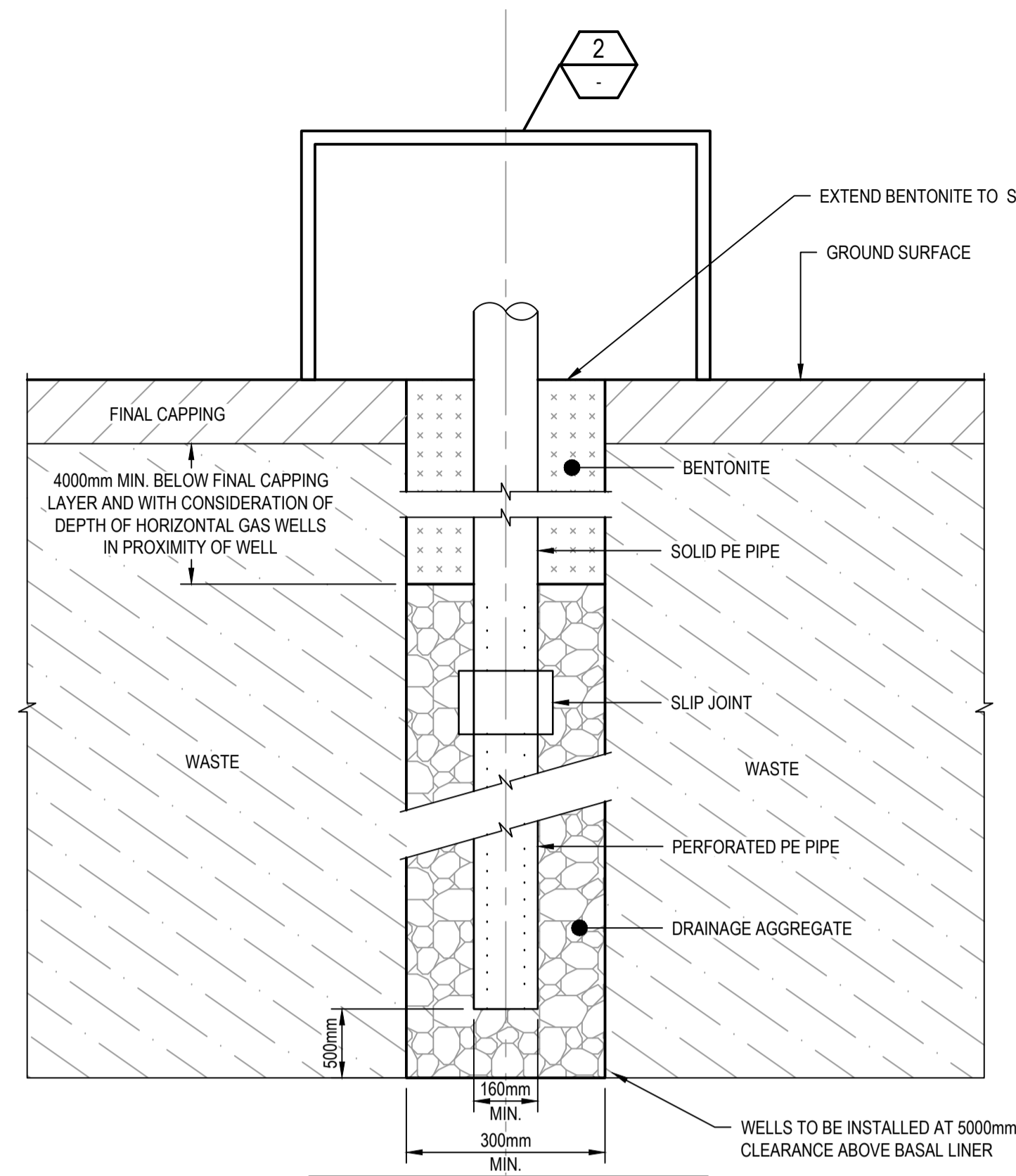

1 DETAIL
C501 N.T.S.

LANDFILL GAS COLLECTION WELL (VERTICAL) (TYP.)

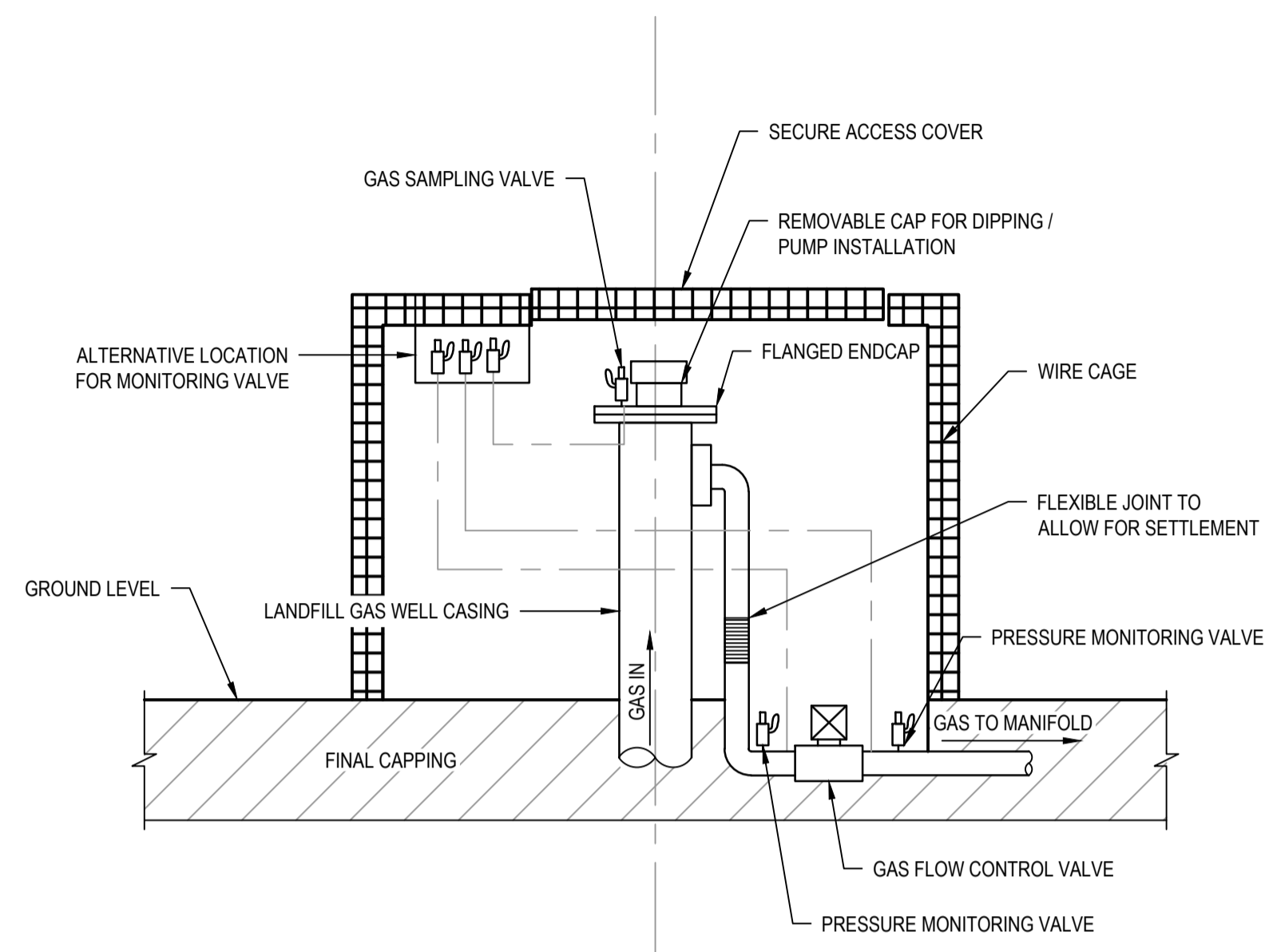

2 DETAIL
N.T.S.

LANDFILL GAS COLLECTION WELL HEAD (TYP.)

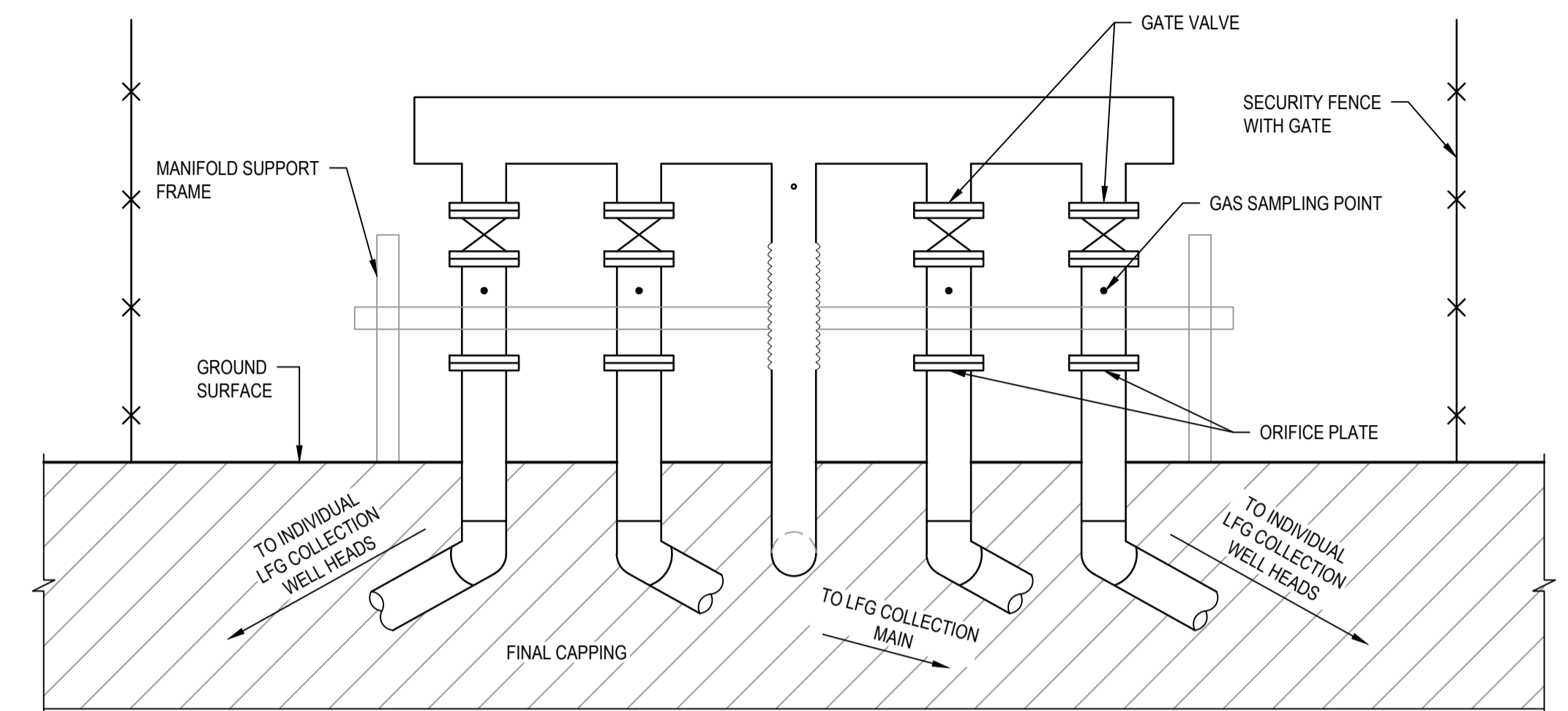

3 DETAIL
C501 N.T.S.

LANDFILL GAS MANIFOLD (TYP.)

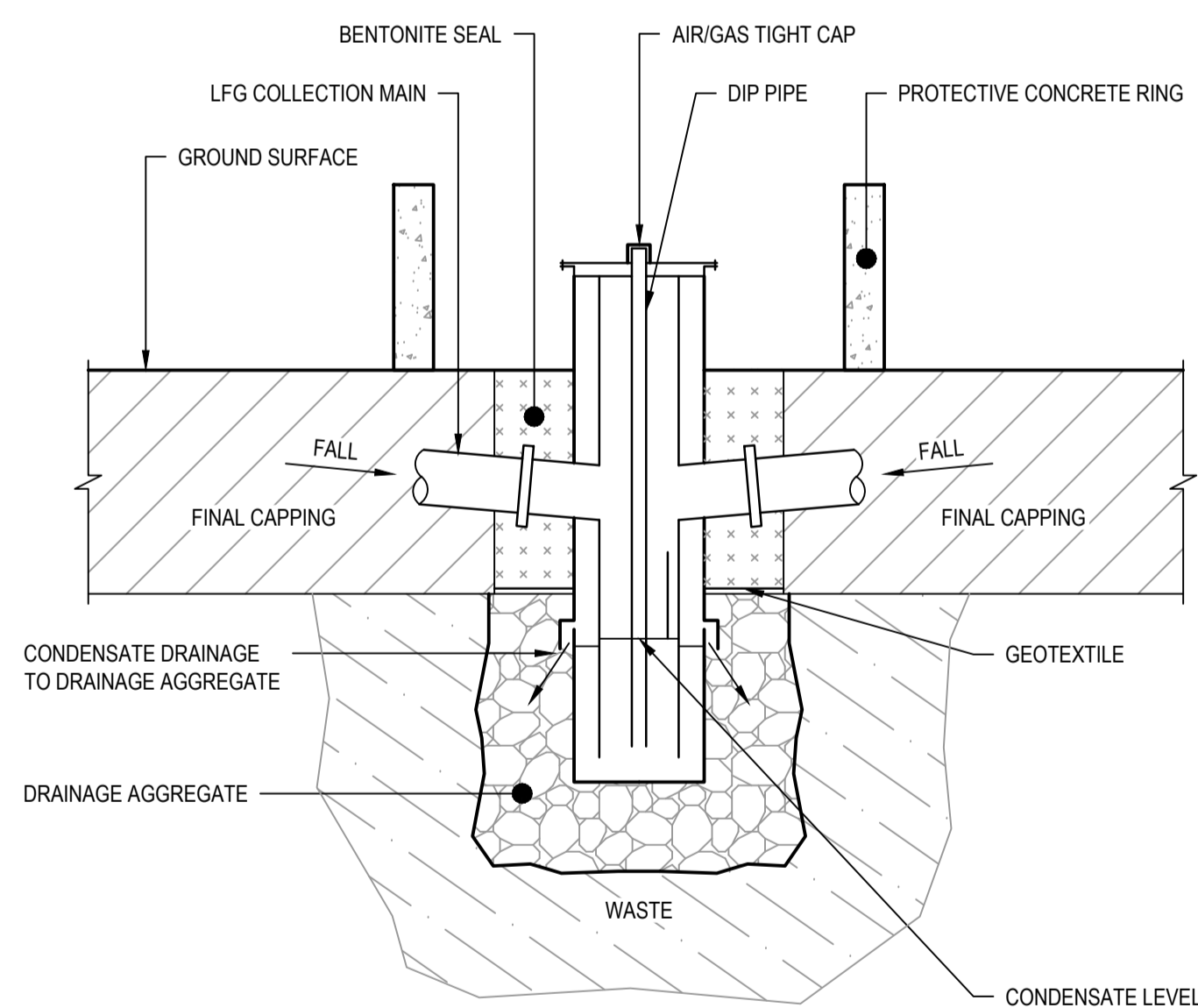

4 DETAIL
C501 N.T.S.

CONDENSATE DRAINAGE POT (TYP.)

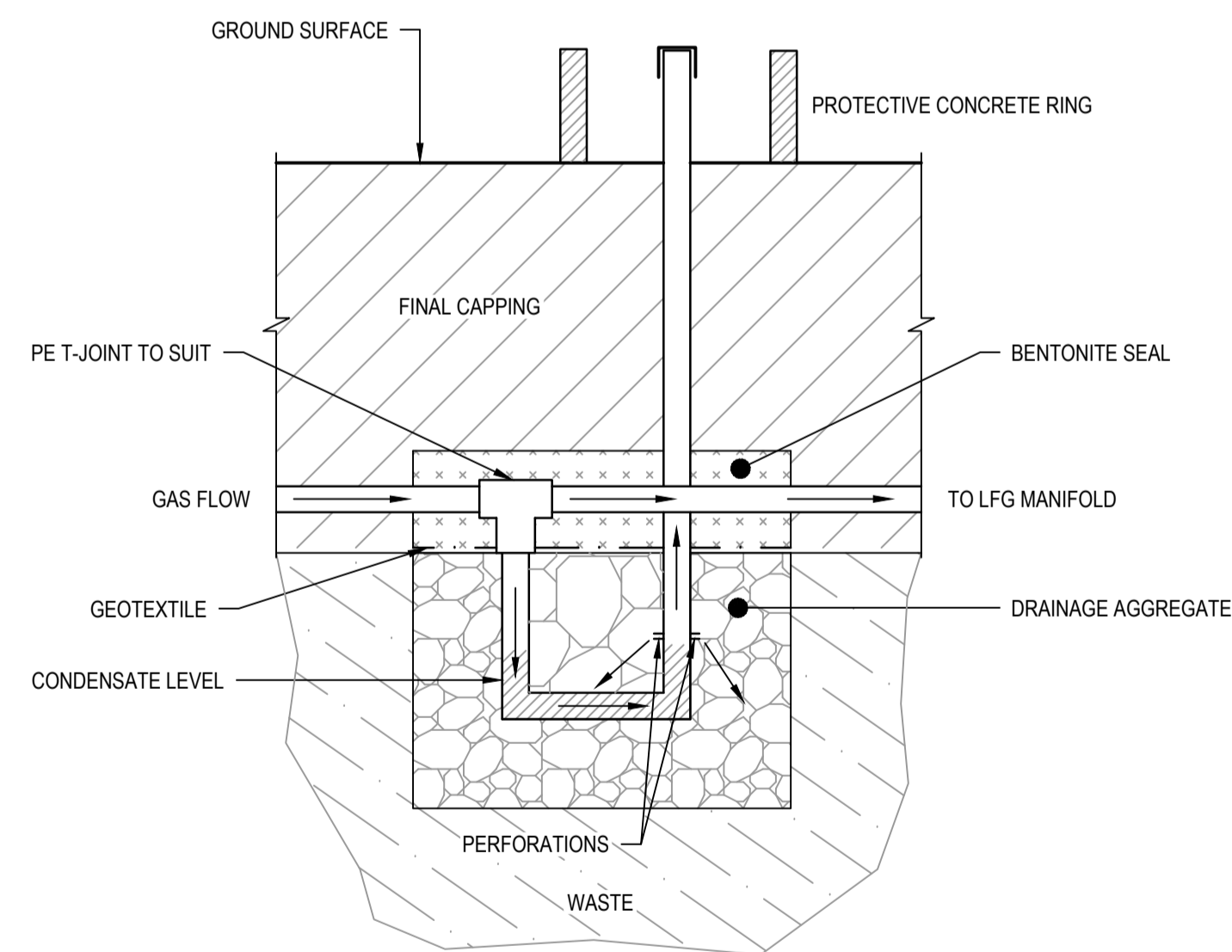

5 DETAIL
C501 N.T.S.

J-TRAP (TYP.)

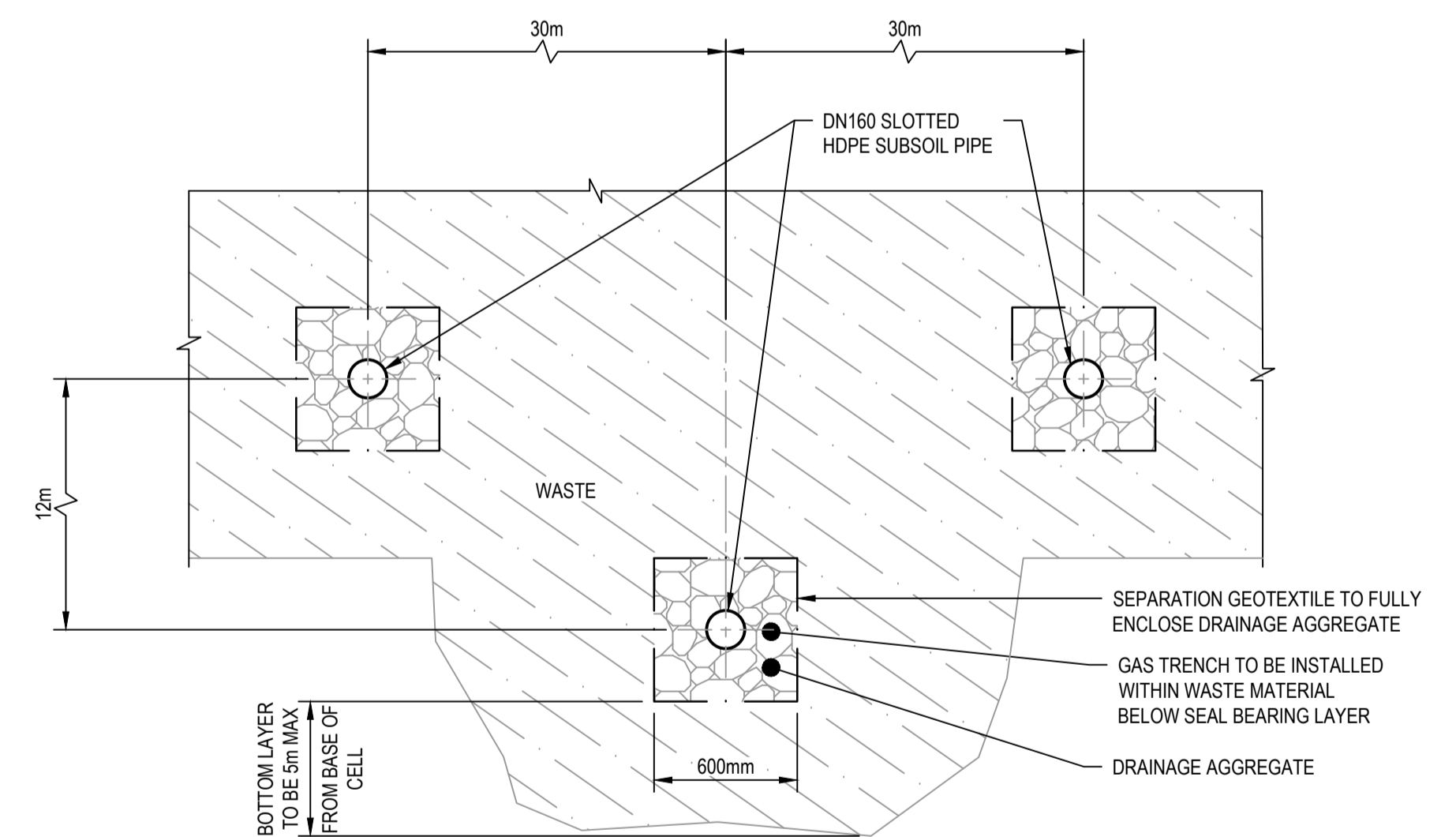

6 DETAIL
N.T.S.

HORIZONTAL LFG WELL
(SEE NOTE 1)

NOTES:

- LAYOUT OF HORIZONTAL LFG WELLS NOT SHOWN ON PLAN C501 DUE TO 3D NATURE.
- NOT FOR CONSTRUCTION.

**FOR CONSENT
NOT FOR CONSTRUCTION**

No	Revision	Note: * indicates signatures on original issue of drawing or last revision of drawing	Drawn	Job Manager	Project Director	Date
2	RE-ISSUE FOR CONSENT		RG	NE*	SD*	21.05.21
1	FOR CONSENT		SLP	NE*	SD*	14.08.20



DO NOT SCALE

GHD Pty Ltd
Conditions of Use.
This document may only be used by GHD's client (and any other person who GHD has agreed can use this document) for the purpose for which it was prepared and must not be used by any other person or for any other purpose.

Drawn	R. GERONIMO	Designer	M. WELSH
Drafting Check	G. DOUGHERTY*	Design Check	N. ELDRED*
Approved (Project Director)	S. DOUGLASS*		
Date	14.08.20		

Scale NOT TO SCALE

This Drawing must not be used for Construction unless signed as Approved

Client **DUNEDIN CITY COUNCIL**
Project **SMOOTH HILL LANDFILL**
Title **LANDFILL GAS MANAGEMENT DETAILS SHEET**

Original Size **A1** Drawing No: **12506381-01-C502**

Rev: 2

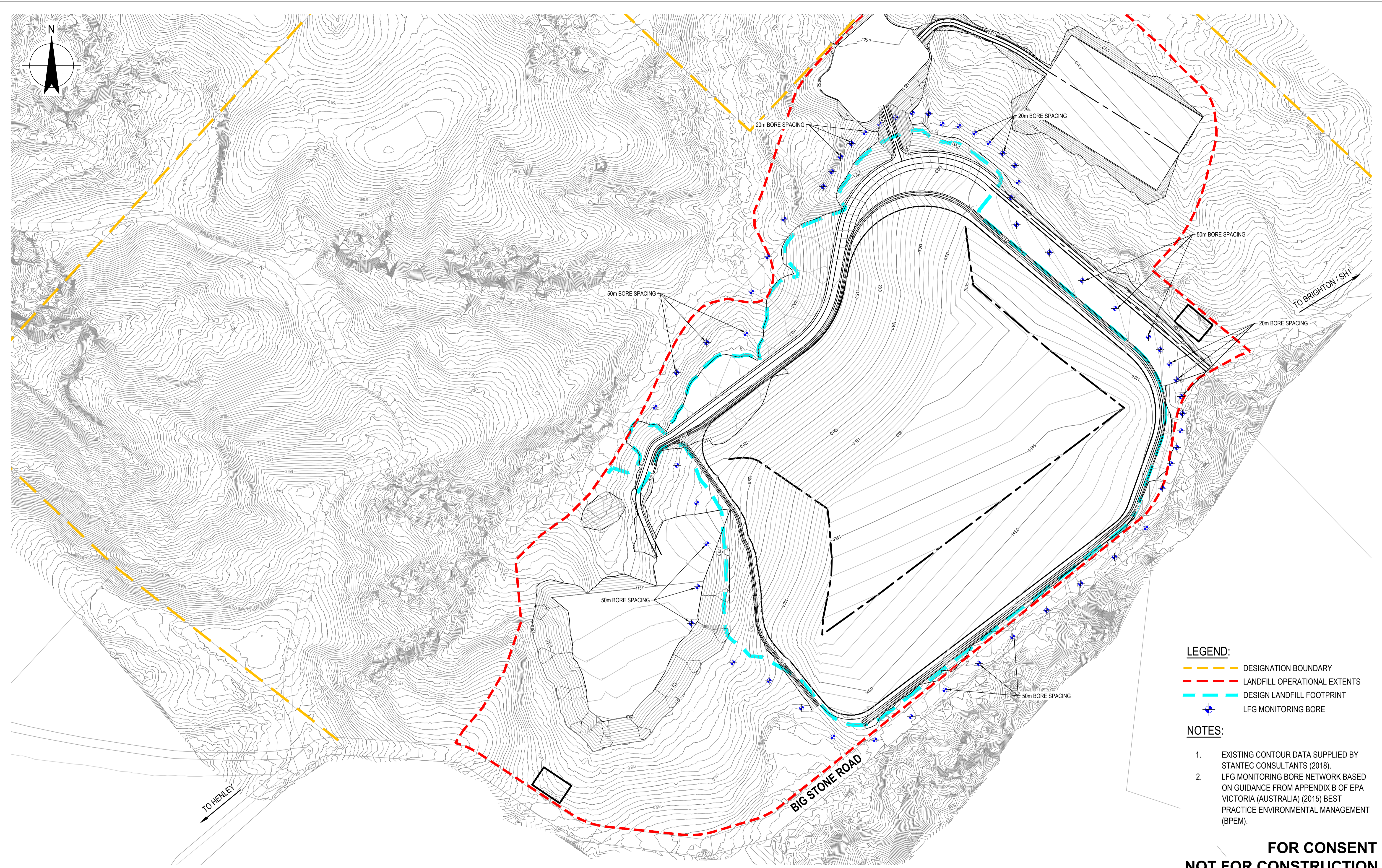

- LEGEND:**
- DESIGNATION BOUNDARY
 - LANDFILL OPERATIONAL EXTENTS
 - DESIGN LANDFILL FOOTPRINT
 - ★ LFG MONITORING BORE

- NOTES:**
1. EXISTING CONTOUR DATA SUPPLIED BY STANTEC CONSULTANTS (2018).
 2. LFG MONITORING BORE NETWORK BASED ON GUIDANCE FROM APPENDIX B OF EPA VICTORIA (AUSTRALIA) (2015) BEST PRACTICE ENVIRONMENTAL MANAGEMENT (BPEM).

**FOR CONSENT
NOT FOR CONSTRUCTION**

No	Revision	Note: * indicates signatures on original issue of drawing or last revision of drawing	Drawn	Job Manager	Project Director	Date
2	RE-ISSUE FOR CONSENT		RG	NE*	SD*	21.05.20
1	FOR CONSENT		SLP	NE*	SD*	14.08.20



DO NOT SCALE

GHD Pty Ltd
Conditions of Use.
This document may only be used by GHD's client (and any other person who GHD has agreed can use this document) for the purpose for which it was prepared and must not be used by any other person or for any other purpose.

Drawn	R. GERONIMO	Designer	M. WELSH
Drafting Check	G. DOUGHERTY*	Design Check	N. ELDRED*
Approved (Project Director)	S. DOUGLASS*		
Date	14.08.20		
Scale	1 : 2000		

Client	DUNEDIN CITY COUNCIL		
Project	SMOOTH HILL LANDFILL		
Title	LANDFILL GAS MANAGEMENT LFG BORE MONITORING NETWORK (EXTREME)		
Original Size	A1	Drawing No:	12506381-01-C503
		Rev:	2

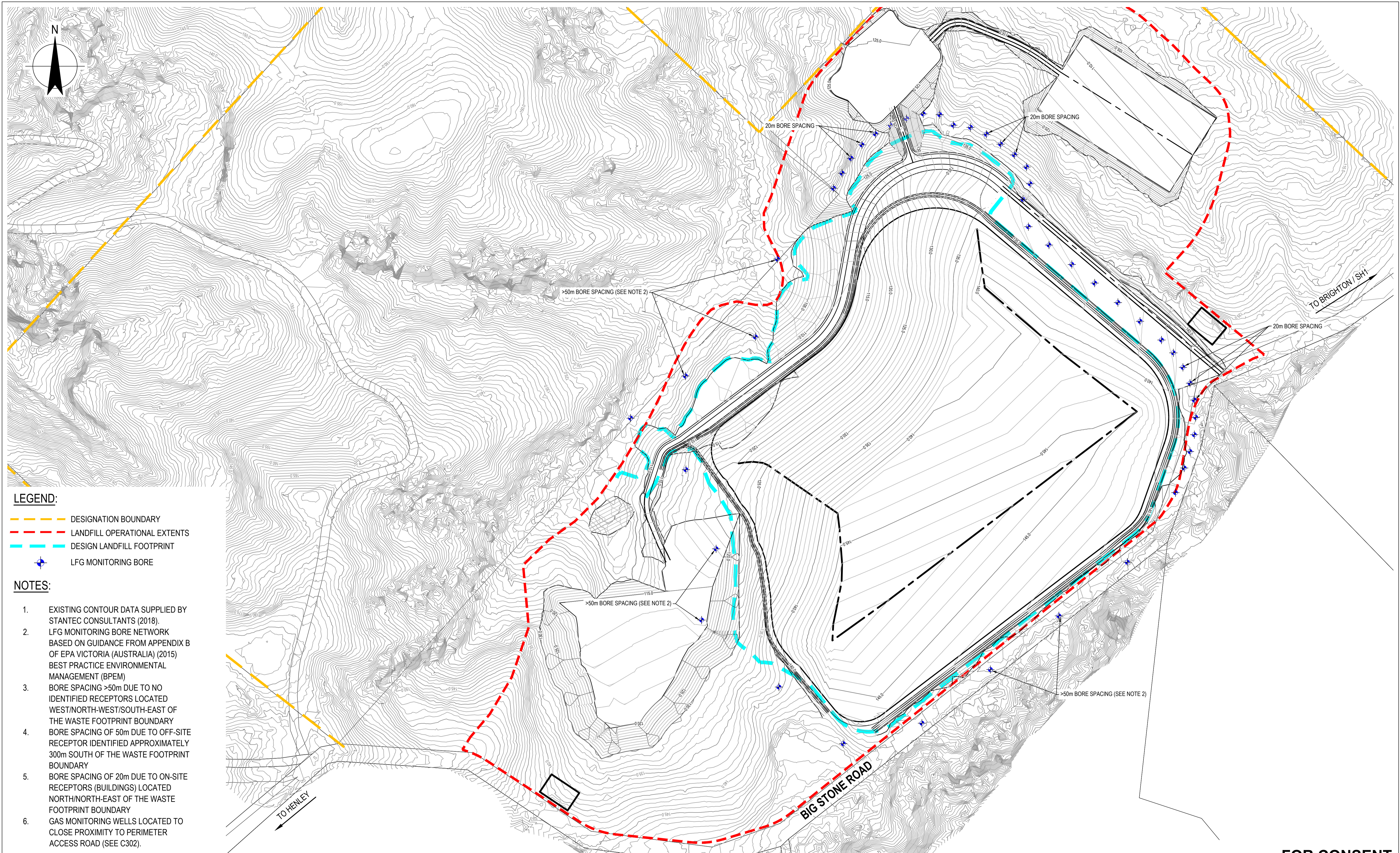

LEGEND:

- DESIGNATION BOUNDARY
- LANDFILL OPERATIONAL EXTENTS
- DESIGN LANDFILL FOOTPRINT
- + LFG MONITORING BORE

NOTES:

1. EXISTING CONTOUR DATA SUPPLIED BY STANTEC CONSULTANTS (2018).
2. LFG MONITORING BORE NETWORK BASED ON GUIDANCE FROM APPENDIX B OF EPA VICTORIA (AUSTRALIA) (2015) BEST PRACTICE ENVIRONMENTAL MANAGEMENT (BPEM)
3. BORE SPACING >50m DUE TO NO IDENTIFIED RECEPTORS LOCATED WEST/NORTH-WEST/SOUTH-EAST OF THE WASTE FOOTPRINT BOUNDARY
4. BORE SPACING OF 50m DUE TO OFF-SITE RECEPTOR IDENTIFIED APPROXIMATELY 300m SOUTH OF THE WASTE FOOTPRINT BOUNDARY
5. BORE SPACING OF 20m DUE TO ON-SITE RECEPTORS (BUILDINGS) LOCATED NORTH/NORTH-EAST OF THE WASTE FOOTPRINT BOUNDARY
6. GAS MONITORING WELLS LOCATED TO CLOSE PROXIMITY TO PERIMETER ACCESS ROAD (SEE C302).

**FOR CONSENT
NOT FOR CONSTRUCTION**

No	Revision	Note	Drawn	Job Manager	Project Director	Date
2	RE-ISSUE FOR CONSENT		RG	NE*	SD*	21.05.21
1	FOR CONSENT		SLP	NE*	SD*	14.08.20

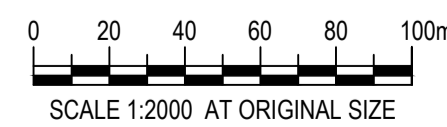

DO NOT SCALE

GHD Pty Ltd
Conditions of Use.
This document may only be used by GHD's client (and any other person who GHD has agreed can use this document) for the purpose for which it was prepared and must not be used by any other person or for any other purpose.

Drawn	R. GERONIMO	Designer	M. WELSH
Drafting Check	G. DOUGHERTY*	Design Check	N. ELDRED*
Approved (Project Director)	S. DOUGLASS*		
Date	14.08.20		
Scale	1 : 2000		

Client	DUNEDIN CITY COUNCIL		
Project	SMOOTH HILL LANDFILL		
Title	LANDFILL GAS MANAGEMENT		
	LFG BORE MONITORING NETWORK (RECOMMENDED)		
Original Size	A1	Drawing No:	12506381-01-C504
		Rev:	2

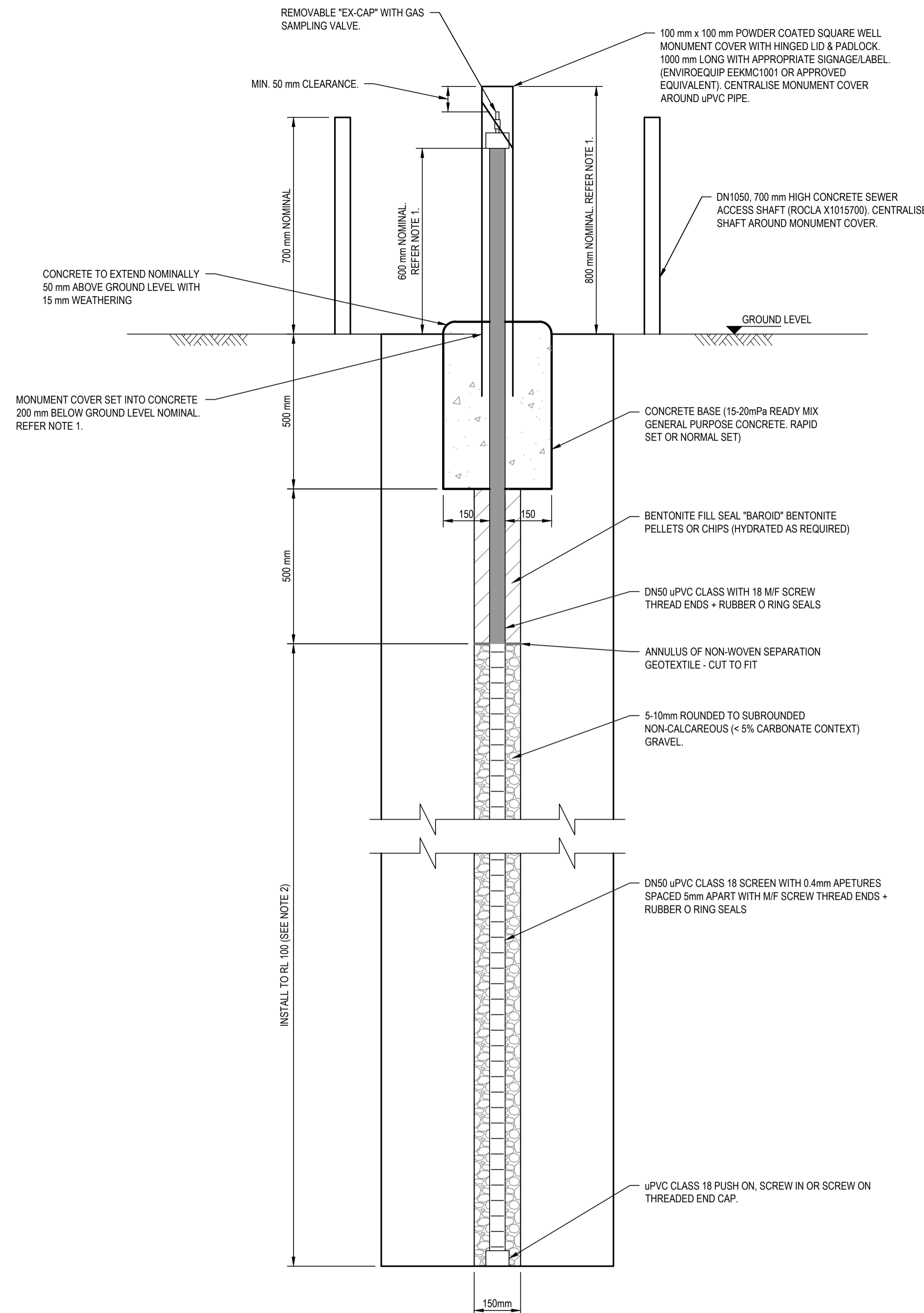

NOTES:

1. ADJUST MONUMENT COVER AS REQUIRED TO ALLOW READY REMOVAL OF "EX-CAP" DURING FUTURE MONITORING EVENTS AND TO ALLOW MONUMENT COVER TO FULLY CLOSE.
2. RL 100 IS THE LOWEST DESIGN LINER SURFACE LEVEL.

6 DETAIL
C501 SCALE 1:10

LANDFILL GAS MONITORING BORE (TYP.)

**FOR CONSENT
NOT FOR CONSTRUCTION**

No	Revision	Note: * indicates signatures on original issue of drawing or last revision of drawing	Drawn	Job Manager	Project Director	Date
2	RE-ISSUE FOR CONSENT		RG	N3*	SD*	21.05.21
1	FOR CONSENT		SLP	NE*	SD*	14.08.20



DO NOT SCALE		Drawn	R. GERONIMO	Designer	M. WELSH	Client	DUNEDIN CITY COUNCIL
GHD Pty Ltd Conditions of Use. This document may only be used by GHD's client (and any other person who GHD has agreed can use this document) for the purpose for which it was prepared and must not be used by any other person or for any other purpose.	Drafting Check	G. DOUGHERTY*	Design Check	N. ELDRED*	Project	SMOOTH HILL LANDFILL	
	Approved (Project Director)	S. DOUGLASS*		Date	14.08.20	Title	LANDFILL GAS MANAGEMENT TYPICAL DETAIL
	Scale	1:10		This Drawing must not be used for Construction unless signed as Approved		Original Size	A1 Drawing No: 12506381-01-C505
							Rev: 2

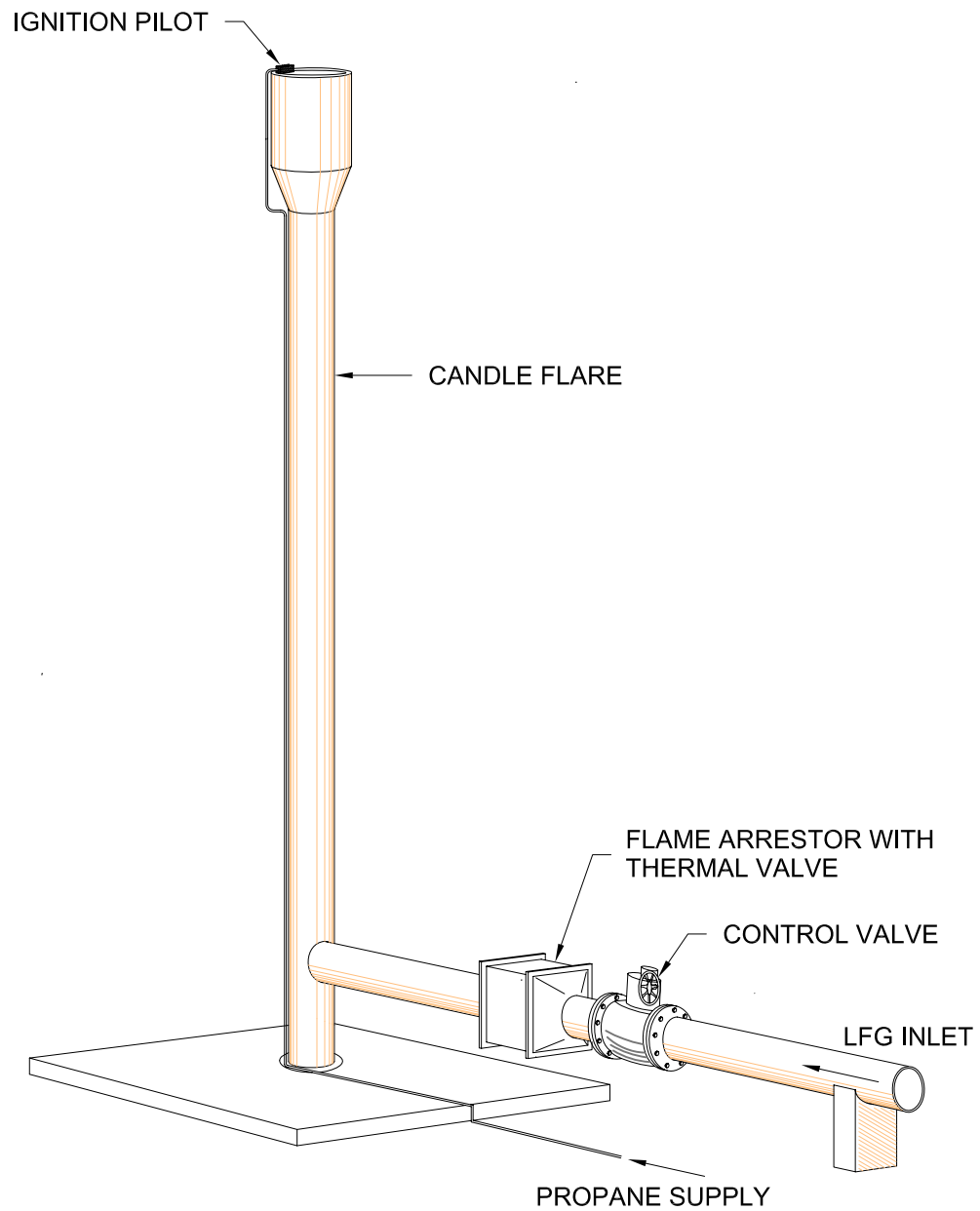

NOT TO SCALE

figure 5.14
LANDFILL GAS CANDLESTICK FLARE



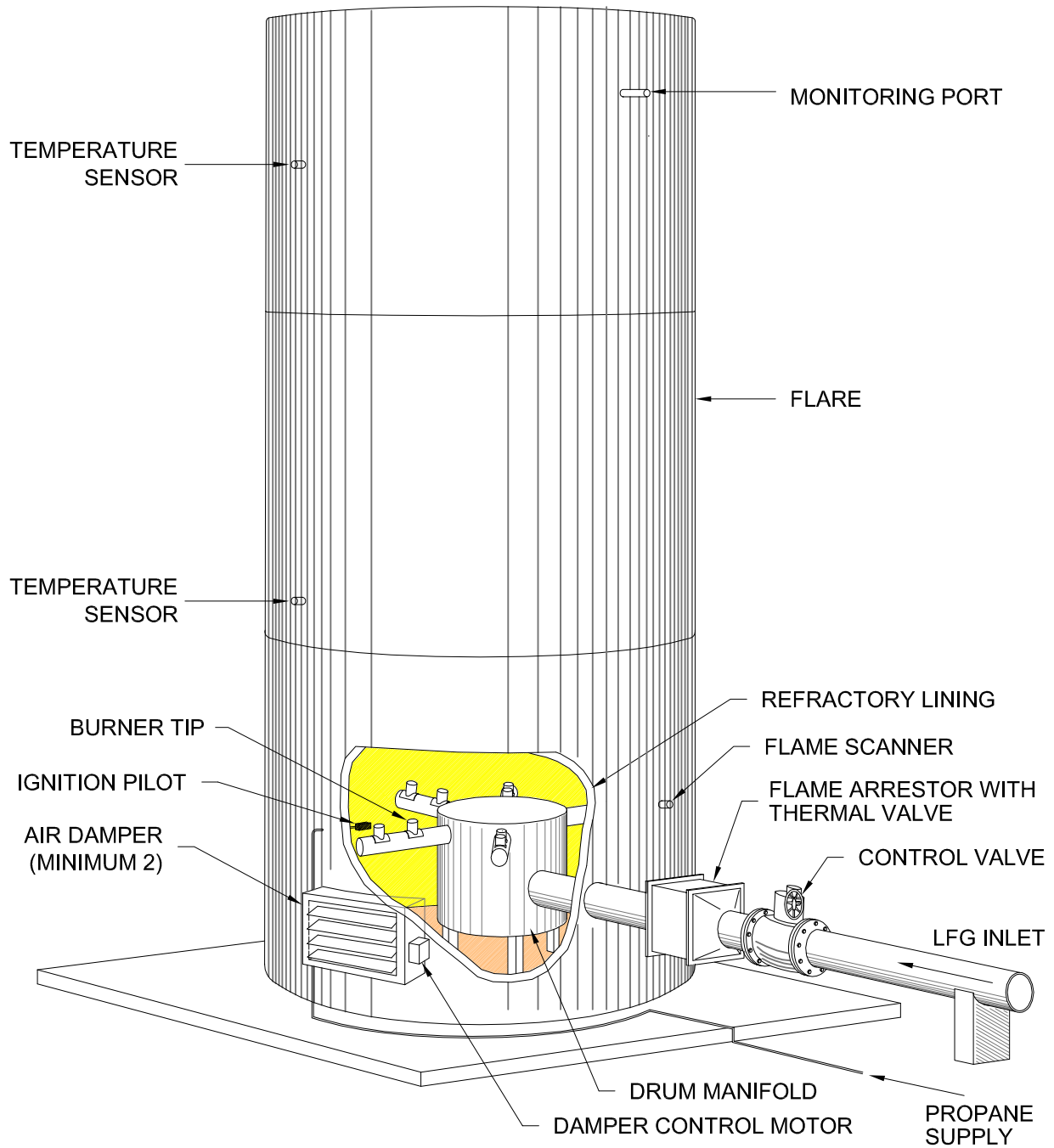

NOT TO SCALE

figure 5.15
ENCLOSED LANDFILL GAS FLARE



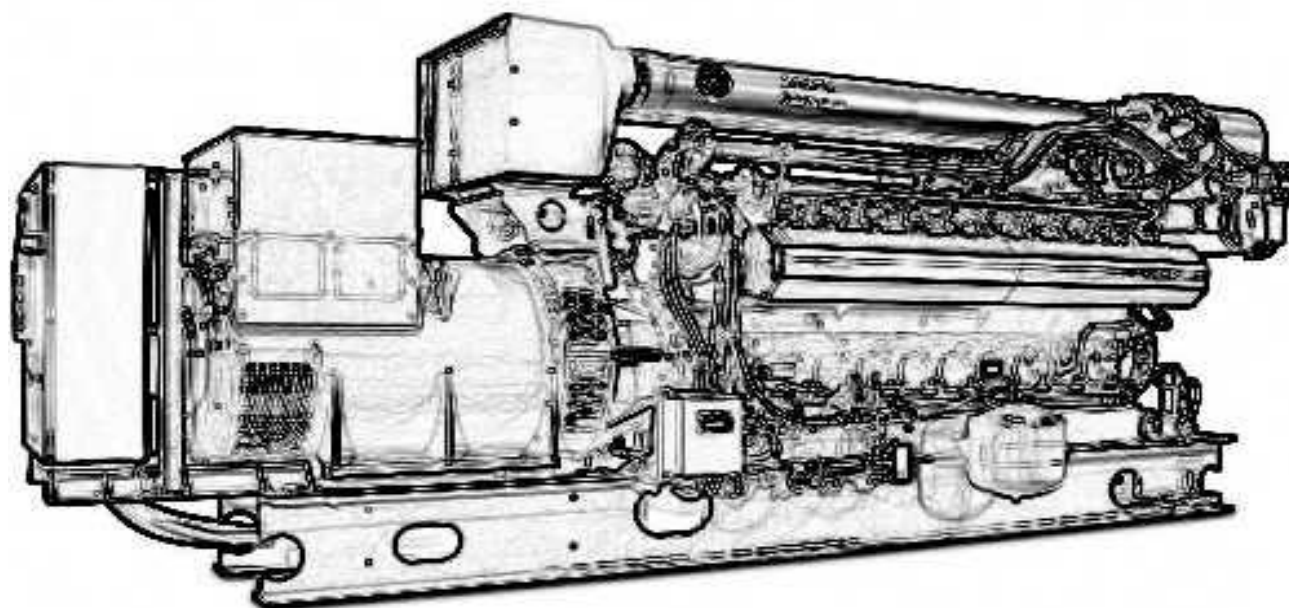

JMS 320 GS-B.L

Biogas 1.063kW el.



JMS 320 GS-B.L Biogas 1.063kW el.

CO-GEN Module data:

Electrical output	kW el.	1.063
Recoverable thermal output (180 °C)	kW	1.103
Energy input	kW	2.606
Fuel Consumption based on a LHV of 4,5 kWh/Nm ³	Nm ³ /h	579
Electrical efficiency	%	40,8%
Thermal efficiency	%	42,3%
Total efficiency	%	83,1%
Heat to be dissipated (LT-Circuit)	kW	67

Emission values:

NOx < 500 mg/Nm³ (5% O₂)

Engine data:

Engine type		J 320 GS-C25
Configuration		V 70°
No. of cylinders		20
Bore	mm	135
Stroke	mm	170
Piston displacement	lit	48,67
Nominal speed	rpm	1.500
Mean piston speed	m/s	8,5
Mean effe. press. at stand. power and nom. speed	bar	18,00
Compression ratio	Epsilon	12,5
ISO standard fuel stop power ICFN	kW	1095
Spec. fuel consumption of engine	kWh/kWh	2,38
Specific lube oil consumption	g/kWh	0,30
Weight dry	kg	5.200
Filling capacity lube oil	lit	370
Based on methane number Min. methane number	MZ(*)	135 100

(*)based on methane number calculation software AVL 3.1

Technical parameters:

Applicable standards:

Based on DIN-ISO 3046

Based on VDE 0530 REM with specified tolerance

reference value --> 65%CH₄ / 35%CO₂

Standard conditions:

Air pressure: 1000 mbar or 100 m above sea level

Air temperature: 25°C or 298 K

Relative Humidity: 30%

Engine output derating:

for plants installed at > 500m above sea level and/or intake temperature > 30°C, the reduction of engine power is determined for each project.

Gas quality:

according to TA 1000-0300

Gas flow pressure: 80 - 200 mbar
(Lower gas pressures upon inquiry)

Max. variation in gas pressure: ±10%

Additional information:

Sound pressure level (engine, average value 1m)	dB(A)	96
Sound pressure level exhaust gas (1m, 30° off engine)	dB(A)	122
Exhaust gas mass flow rate, wet	kg/h	5.642
Exhaust gas volume, wet	Nm ³ /h	4.387
Max.admissible exhaust back pressure after engine	mbar	60
Exhaust gas temperature at full load	°C [8]	450
Combustion air mass flow rate	kg/h	5.176
Combustion air volume	Nm ³ /h	4.004
Max. inlet cooling water temp. (intercooler)	°C	50
Max. pressure drop in front of intake-air filter	mbar	10
Return temperature	°C	70
Forward temperature	°C	90
Hot water flow rate	m ³ /h	47,4

Alternator:

Manufacturer	Leroy-Somer e)	
Type	LSAC 50.2 VL10 e)	
Type rating	kVA	1.475
Efficiency at p.f. = 1,0	%	97,1%
Efficiency at p.f. = 0,8	%	96,1%
Ratings at p.f. = 1,0	kW	1.063
Ratings at p.f. = 0,8	kW	1.052
Frequency	Hz	50
Voltage	V	400
Protection Class		IP 23
Insulation class		H
Speed	rpm	1.500
Mass	kg	3.300

All data are based on engine full load at specified media temperatures and are subject to change.

The technical Instruction TA 1100-0110 "PARAMETER FOR GE Jenbacher GAS ENGINES" must be strictly observed.



>>> Scope of supply genset - JGS 320 GS-B.L

Basic engine equipment:

- *Exhaust gas turbocharger, Intercooler
- *Motorized carburator for LEANOX control
- *Electronic contactless high performance ignition system
- *Lubricating oil pump (gear driven)
- *Lubricating oil filters in main circuit
- *Lubricating oil sump; Lubricating oil heat exchanger
- *Jacket water pump
- *Fuel-, lubricating oil and jacket water pipe work on engine
- *Flywheel for alternator operation; Exhaust gas manifold
- *Viscous damper
- *Knock sensors

Engine accessories:

- *Electric starter motor
- *Electronic speed governor
- *Electronic speed monitoring device including starting and overspeed control
- *Transducers and switches for oil pressure, jacket water temp., jacket water pressure, charge pressure and mixture temperature
- *One thermocouple per cylinder

Supplied loose:

Gas train according to DIN-DVGW consisting of:

- *Manual stop valve, fuel gas filter, two solenoid valves, Leakage control device, gas pressure regulator

Documentation:

- *Operating and maintenance manual
- *Spare parts manual
- *Drawings

Assembly, painting, testing in Jenbach/Austria

>>> Scope of supply module - JMS 320 GS-B.L

Identical to Genset except that heat recovery is included.

- *jacket water heat exchanger mounted on module frame
- *exhaust gas heat exchanger delivered loose
- *all heat exchangers with complete pipework
- *Heat exchangers and all inherent auxiliaries

>>> Scope of supply container - JG(M)C 320 GS-B.L

- *Identical to module/genset but installed in 40' ISO container (65 dB(A) @ 10m); complete with all pipework and fittings
- *Twin circuit radiation cooler for dissipation of intercooler jacket water and lube oil thermal output; ventilation equipment
- *Gas & smoke detectors; exhaust silencer; lube oil equipment; starting system; flexible connections
- *Separate control room complete with generator switchgear and all internal power and monitoring cables

Module equipment:

- *Base frame for gas engine, alternator and heat exchangers
- *Internal pole alternator with excitation alternator and with automatic voltage regulator; p.f. 0,8 lagging to 1,0
- *Flexible coupling, bell housing
- *Anti-vibration mounts
- *Air filter
- *Automatic lube oil replenishing with level control
- *Wiring of components to module interface panel
- *Crankcase breather
- *Jacket water electric preheating

Module control panel:

- *Totally enclosed, single door cubicle, wired to terminals and ready to operate, protection IP 40 outside, IP 10 inside, according to VDE-standards

Control equipment:

- *Engine-Management-System dia.ne (Dialog Network)
- **Visualisation (industry PC-10,4" color graphics display): Operation data, controller display, Exh. gas temp., Generator electr. connection, etc.
- **Central engine- and module control: Speed-, Power output-, LEANOX-Control and knock control, etc.
- *Multi-transducer
- *Lockable operation mode selector switch
Positions: "OFF", "MANUAL", "AUTOMATIC"
- *Demand switch



Genset

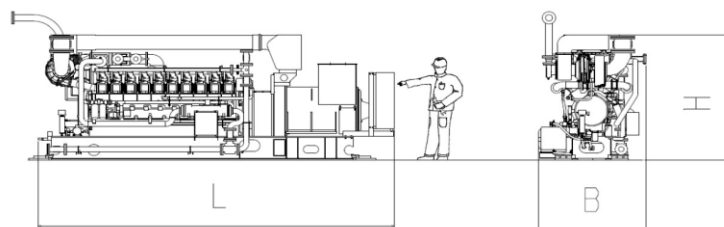

Main dimensions and weights (approximate value)		
Length L	mm	5.700
Width B	mm	1.700
Height H	mm	2.300
Weight empty	kg	13.600
Weight filled	kg	14.100

Connections (at genset)		
Jacket water inlet and outlet	DN/PN	80/10
Exhaust gas outlet	DN/PN	250/10
Fuel gas (at gas train)	DN/PN	100/16
Intercooler water connection:		
Low Temperature Circuit	DN/PN	65/10

Module

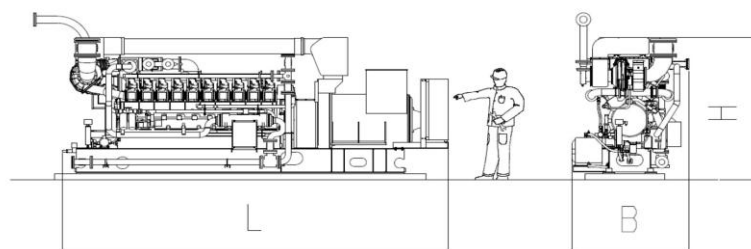

Main dimensions and weights (approximate value)		
Length L	mm	5.700
Width B	mm	1.900
Height H	mm	2.300
Weight empty	kg	14.100
Weight filled	kg	14.600

Connections (at module)		
Hot water inlet and outlet	DN/PN	80/10
Exhaust gas outlet	DN/PN	250/10
Fuel gas (at gas train)	DN/PN	100/16
Intercooler water connection:		
Intercooler water-Inlet/Outlet 2nd stage	DN/PN	65/10

Container

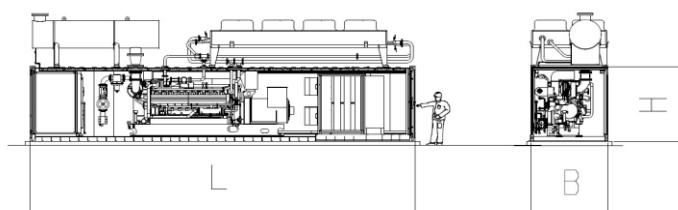

Main dimensions and weights (approximate value)		
Length L	mm	12.200
Width B	mm	2.500
Height H	mm	2.600
Container weight (dry)	kg	29.600
Container weight (filled)	kg	31.100

Connections (container)		
Jacket water inlet and outlet	DN/PN	80/10
Exhaust gas outlet	DN/PN	250/10
Fuel gas connection (container)	mm	150/16
Fresh oil connection	G	28x2"

This report was technically directed and reviewed by Matt Welsh, a Senior Environmental Scientist at GHD. Matt has over 20 years experience in the area of landfill gas assessment and management. He has the following qualifications and institutional memberships: BSc. (Hons) 1st Class Environmental Science – University of Sussex, 1998, member of Australian Contaminated Land Consultants Association (ACLCA). The lead author for this report was Fabrice Cheong, a mid-level Civil and Environmental at GHD. Fabrice has 7 years' experience in waste management, including landfill gas assessment and management. He has a B.Eng Civil Engineering and M.Eng Environmental Engineering. He is a member of Waste Management & Resource Recovery Association Australia.





GHD

Level 3, GHD Centre
 27 Napier Street
 T: 64 9 370 8000 F: 64 9 370 8001 E: akmail@ghd.com

© GHD 2019

This document is and shall remain the property of GHD. The document may only be used for the purpose for which it was commissioned and in accordance with the Terms of Engagement for the commission. Unauthorised use of this document in any form whatsoever is prohibited.

Document Status

Revision	Author	Reviewer		Approved for Issue		
		Name	Signature	Name	Signature	Date
Rev01	F. Cheong	M. Welsh / R Coombe		Stephen Douglass		17-08-20
Rev02	F. Cheong	M. Welsh		Stephen Douglass		22-05-21

www.ghd.com



This report has been prepared in part by [Paul Abbot, a civil engineer at GHD with over 15 years experience](#) years' experience under the direction of Richard Coombe, an associate and civil engineer at GHD Ltd. Richard has over 20 years experience as a landfill engineer and has the following qualifications and institutional memberships: NZCE (Civil), NZCLS, CPEng and a member of Engineering New Zealand and member of Australasian Land and Groundwater Association and member of the Society of Construction Law. The author would also like to acknowledge the assistance of Nick Eldred (Authoring Sections 1, 2 and 9) and Matt Welsh (Authoring Section 4) in the preparation of this report.





GHD

Level 4 Security Building
115 Stuart Street
T: 64 3 378 0991

© GHD 2021

This document is and shall remain the property of GHD. The document may only be used for the purpose for which it was commissioned and in accordance with the Terms of Engagement for the commission. Unauthorised use of this document in any form whatsoever is prohibited.

Document Status

Revision	Author	Reviewer		Approved for Issue		
		Name	Signature	Name	Signature	Date
Rev01	Richard Coombe	Nick Eldred		Stephen Dougalss		13-08-20
Rev02	Paul Abbot	Nick Eldred		Stephen Douglass		22-05-21

www.ghd.com



