

**Ambient air quality in Otago
Particulates 2005-2008**

Otago Regional Council
Private Bag 1954, 70 Stafford St, Dunedin 9054
Phone 03 474 0827 Fax 03 479 0015
Freephone 0800 474 082
www.orc.govt.nz

© Copyright for this publication is held by the Otago Regional Council. This publication may be reproduced in whole or in part provided the source is fully and clearly acknowledged.

ISBN 1-877265-88-8

Published November 2009

Chairman's foreword

Awareness of air quality issues has grown significantly since the Otago Regional Council (ORC) started monitoring over a decade ago. The Otago region experiences very good air quality most of the year; however, there are times, especially during the winter, when residents can suffer from high levels of air pollution from smoke as we still rely on the use of solid fuel such as coal and wood to heat our houses.

There have been some rigorous debates recently about the advantages and disadvantages of modern methods of home heating and research has shown high air pollution levels and cold homes are associated with exacerbating health problems, including respiratory and heart-related diseases. These effects are particularly noticeable in the elderly, the very young, and those people who are already experiencing respiratory problems.

National Environmental Standards (NES) for ambient air quality in New Zealand were introduced by the Ministry for the Environment (MfE) in September 2005. Otago's main pollutant is the small suspended particles (PM₁₀) found in smoke. The allowable limit for PM₁₀ is 50 micrograms per cubic metre of air as an average over a day.

ORC now has an established network of 11 air quality monitors operating around the region. Results show a wide range of air quality, with several of the larger Central Otago towns and Milton having very poor air quality during winter.

ORC is committed to improving air quality and creating a healthier environment. Our Regional Policy Statement provides for the sustainable management of the air resource and the Regional Air Plan sets out the policies, rules, and objectives for enhancing the quality of air.

We have partnered with the Energy Efficiency and Conservation Agency and other Otago community organisations to operate the Otago Clean Heat Clean Air warm home assistance programme. This programme provides assistance for residents to upgrade their heating appliances thereby reducing emissions to air. To date, the programme has helped several hundred householders improve the heating and insulation in their home.

This report summarises the ORC air quality monitoring programme, which has been in operation since 1997. The monitoring programme identifies those areas where air pollution is a problem and helps Council and our Otago communities not only understand the extent and nature of the problem, but also measures the improvements made so far.

Stephen Cairns
Chairman

Executive summary

Air is one of Otago's valuable resources. Good air quality serves as a valuable amenity to the community, generally enhancing the quality of life and promoting good health. Otago residents enjoy good air quality in most places during much of the year. However, there are times of the year when air quality suffers as a result of increased particulates in the air. The most common source of these pollutants is solid fuel burners used for domestic heating.

During the past decade, awareness of air quality issues has grown significantly. There is a much greater understanding of the links between increased particulates and adverse health risks. International, national, and local research has shown that long-term exposure to elevated PM₁₀ is associated with increased respiratory distress, cardiopulmonary disease and, in extreme cases, premature death.

In 2004, the Ministry for the Environment (MfE) established Air Quality National Environmental Standards (AQNES) to be met by the year 2013. The Otago Regional Plan: Air for Otago (Air Plan) was revised (effective 1 January 2009) and provides the framework for achieving this goal. To define and measure our progress, the Otago Regional Council (ORC) adopted a pro-active air quality monitoring programme over the past five years. Continuous, daily monitoring has taken place in 11 towns throughout the region in an effort to characterise the extent of air quality issues affecting residents.

This State of the Environment (SOE) report is a summary and discussion of PM₁₀ monitoring results from 2005 to 2008. A previous report, *Ambient Air Quality in Otago, Particulates* (ORC, 2005a), detailed the results from earlier monitoring from 1997 to 2004.

The main points from the four years of SOE analysis are:

- Good quality air is generally found at all monitored sites outside of the winter months.
- A significant number of AQNES exceedances occur every winter in Central Otago towns and in Milton. A moderate number occur in Mosgiel, Central and South Dunedin. Oamaru and North Dunedin have experienced just a few exceedances.
- Alexandra has the highest annual average ($26\mu\text{g}/\text{m}^3$), the highest May-August average ($49\mu\text{g}/\text{m}^3$), and the greatest number of days a year over $50\mu\text{g}/\text{m}^3$ (average of 48 days a year).
- Arrowtown has had the highest one-day PM₁₀ value ($168\mu\text{g}/\text{m}^3$).
- Milton has the greatest percentage of days over the Otago goal level of $35\mu\text{g}/\text{m}^3$ at 35% and the second highest average number of days over the AQNES (46 days).
- PM₁₀ levels in Clyde and Cromwell can exceed $100\mu\text{g}/\text{m}^3$ during the winter.
- Central Dunedin experiences higher values of PM₁₀ in spring, summer and autumn, than other towns in Otago.
- Except for North Dunedin, which has shown a marked decrease in PM₁₀ levels over several years, it is not yet possible to identify significant trends in air quality at any other site.

ORC is committed to achieving the standards set by MfE and the goals established in the Air Plan. Each year we check our progress by comparing results against previously-established targets known as curved-line or straight-line paths. Monitoring will continue where problems have been identified. Mitigation measures are underway in several areas, and studies are planned to gain even more understanding about the nature of the problems.

Table of contents

Chairman’s foreword.....	ii
Executive summary	iii
1. Introduction.....	1
1.1 Air quality indicators	2
1.2 Summary results and key findings.....	3
1.3 Monitoring background	4
1.4 PM ₁₀ and health	5
2. Monitoring programme	8
2.1 Establishment of the AQNES monitoring network	8
2.2 Sampling methods	8
3. Summary of results – Otagowide.....	15
3.1 Annual and summary statistics	15
3.2 Seasonal differences	17
3.3 Category frequencies	18
3.4 Regional differences	19
4. PM ₁₀ results: individual sites	22
4.1 Alexandra.....	22
4.2 Arrowtown.....	28
4.3 Clyde.....	30
4.4 Cromwell	32
4.5 Central Dunedin.....	34
4.6 North Dunedin	36
4.7 South Dunedin.....	39
4.8 Lawrence	41
4.9 Milton	42
4.10 Mosgiel	44
4.11 Naseby	49
4.12 Oamaru	52
4.13 Ranfurly	53
4.14 Roxburgh	55
5. Otago’s path to the National Environmental Standard	58
5.1 Alexandra and Arrowtown	58
5.2 Clyde.....	58
5.3 Cromwell	59
5.4 Central Dunedin.....	59
5.5 Milton	60
5.6 Oamaru	61
5.7 Mosgiel	61
6. Mitigation.....	63
7. References.....	65

List of figures

Figure 1.1	Air quality indicators	2
Figure 2.1	Ideal exposure of 120° from PM ₁₀ sampling point	8
Figure 2.2	Four filters from an intermittent high-volume monitor with daily samples taken in Lawrence during September 2008. Values (in µg/m ³) are shown for each	9
Figure 2.3	Examples of exposed filters from a BAM monitor. Each circle represents one hour of sampled PM ₁₀	10
Figure 2.4	Otago map showing the locations of all monitoring sites from 2005 to 2008	12
Figure 2.5	Timeline showing when PM ₁₀ monitors were active at each site. Sites where the bar extends through to December 2008 are currently active.....	13
Figure 2.6	A typical continuous beta monitoring site	14
Figure 3.1	Annual average PM ₁₀ values. (To compute an annual average, 274 out of 365 days must be sampled, or 75% of the year. Some of the 14 sites were only monitored during the colder months of the year and others have been out of service for lengthy periods; those sites have not met the 75% criteria)	15
Figure 3.2	An inter-seasonal comparison of average daily PM ₁₀ values across Otago. The green bars represent the average day's value from May to August. The striped bars indicate the average day's value over all other months of the year.....	17
	* Naseby, Ranfurly, and Roxburgh were only monitored from May to August.....	17
Figure 3.3	Proportions of days that were high, medium and low pollution days in the 14 centres monitored from 2005 to 2008. Note some monitors (Roxburgh, Naseby, Ranfurly) were only run over the winter months when PM ₁₀ levels are higher so they will show higher proportions of medium pollution days than others	18
Figure 3.4	Three-season box plots of Central Dunedin and Alexandra. The scale on the left is PM ₁₀ in µg/m ³	20
Figure 4.1	Daily PM ₁₀ values for Alexandra from 2005 to 2008.....	22
Figure 4.2	Box plots of monthly summary values for Alexandra (June 2005 – December 2008).....	23
Figure 4.3	Average hourly concentrations of PM ₁₀ in Alexandra depicted for: All the data, Winter months (May-August), and Summer months (December-March)	24
Figure 4.4	Trends in PM ₁₀ air quality at Alexandra from 1997 to 2008	24
Figure 4.5	Average hourly temperature at Ventry Street and on the Hilltop measured on 8-9 July 2008	25
Figure 4.6	Scatter plot of daily average PM ₁₀ and the intensity of the inversion layer during winter 2008. The intensity of the inversion layer here is taken to be the average temperature difference between the top temperature logger on the hill and at the ORC monitoring station in Ventry Street. The higher the number, the stronger the inversion.....	26
Figure 4.7	The effect of cold air drainage on synoptic airflow over complex terrain. Source: Sturman and Tapper, 2006, p 317	27

Figure 4.8	Daily PM ₁₀ values for Arrowtown from July 2006 to December 2008.....	28
Figure 4.9	Box plots of monthly summary values for Arrowtown (July 2006-Dec 2008)	29
Figure 4.10	Diurnal trends in PM ₁₀ at Arrowtown.....	29
Figure 4.11	Daily PM ₁₀ values for Clyde in 2008.....	30
Figure 4.12	Box plots of monthly summary values for Clyde (Apr 2008 - December 2008).....	31
Figure 4.13	Diurnal trends in PM ₁₀ at Clyde.....	31
Figure 4.14	Daily PM ₁₀ values for Cromwell from January 2008 to December 2008	32
Figure 4.15	Box plots of monthly summary values for Cromwell (January 2008 – December 2008).....	33
Figure 4.16	Diurnal trends in PM ₁₀ at Cromwell	33
Figure 4.17	Daily PM ₁₀ values for Central Dunedin from 2006 to 2008.....	34
Figure 4.18	Box plots of monthly summary values for Central Dunedin (2006 -2008).....	34
Figure 4.19	Average hourly concentrations of PM ₁₀ in Central Dunedin depicted for: All data, Winter months (May-August), and Summer months (December – March).....	35
Figure 4.20	Trends in PM ₁₀ air quality at Central Dunedin from 1997 to 2008.....	36
Figure 4.21	Recorded daily average PM ₁₀ levels in North Dunedin from 2005 to 2007	36
Figure 4.22	Box plots of monthly summary values for North Dunedin.....	37
Figure 4.23	Trend in PM ₁₀ levels in North Dunedin from 1997 to 2007.....	38
Figure 4.24	Trends in the use of fuel type from 1996 to 2006 (Census of Population and Dwellings, Statistics NZ).....	38
Figure 4.25	Recorded daily average PM ₁₀ levels in South Dunedin from 2007 to 2008	39
Figure 4.26	Box plots of monthly summary values for South Dunedin (2007 - 2008).....	40
Figure 4.27	The diurnal pattern of PM ₁₀ measured in South Dunedin by the Geography Department of The University of Otago	41
Figure 4.28	Daily recorded PM ₁₀ levels in Lawrence during 2008.....	41
Figure 4.29	Daily PM ₁₀ values for Milton during 2008.....	42
Figure 4.30	Contribution to PM ₁₀ emissions from domestic heating appliances in Milton.....	43
Figure 4.31	Diurnal trends in PM ₁₀ at Milton	43
Figure 4.32	Box plots of monthly summary values for Milton in 2008.....	44
Figure 4.33	Daily PM ₁₀ values in Mosgiel from May 2005 to December 2009.....	44
Figure 4.34	Box plots of monthly summary values for Mosgiel (June 2005 – Dec 2008).....	45
Figure 4.35	Trends in PM ₁₀ air quality at Mosgiel from 2001 to 2008.....	46
Figure 4.36	Average hourly concentrations of PM ₁₀ in Mosgiel depicted for: All data, Winter months (May-August), and Summer months (December - March).....	47

Figure 4.37	Average PM ₁₀ (ug/m ³) recorded across Mosgiel during the study period. The blue dots indicate sampling sites used and the pink dot indicates the location of the ORC BAM monitor	48
Figure 4.38	Daily PM ₁₀ values for Naseby during 2007	49
Figure 4.39	Box plots of monthly values for Naseby during 2007	50
Figure 4.40	Diurnal trends in PM ₁₀ at Naseby	51
Figure 4.41	Daily PM ₁₀ values for Oamaru from June 2008 – December 2008.....	52
Figure 4.42	Diurnal trends in PM ₁₀ at Oamaru	53
Figure 4.43	Box plots of monthly summary values for Oamaru during 2008	53
Figure 4.44	Daily PM ₁₀ values for Ranfurly during the winters of 2007 and 2008.....	54
Figure 4.45	Box plots of monthly summary values for Ranfurly during 2007 – 2008.....	55
Figure 4.46	Diurnal trends in PM ₁₀ at Ranfurly	55
Figure 4.47	Daily PM ₁₀ values for Roxburgh during 2007.....	56
Figure 4.48	Box plots of monthly summary values for Roxburgh from May 2008 to September 2008	57
Figure 4.49	Diurnal trends in PM ₁₀ at Roxburgh	57
Figure 5.1	Alexandra and Arrowtown’s curved-line path is shown in blue and each town’s second-highest daily PM ₁₀ value is plotted against it.....	58
Figure 5.2	Clyde’s CLP plotted with the second highest value in 2008	59
Figure 5.3	Cromwell’s CLP plotted with the second highest value for 2008	59
Figure 5.4	Central Dunedin’s SLP plotted with each year’s second highest value.....	60
Figure 5.5	Milton’s SLP with 2008’s second highest value plotted	60
Figure 5.6	Oamaru’s SLP with 2008’s second highest value plotted	61
Figure 5.7	Mosgiel’s CLP plotted with each year’s second highest value.....	61

List of tables

Table 1.1	Air Zone designations for Otago.....	5
Table 2.1	PM ₁₀ monitoring sites with their characteristics and sampling frequencies.....	11
Table 3.1	Summary statistics for PM ₁₀ monitoring sites in Otago 2005-2008.	16
Table 4.1	Summary statistics for Alexandra (PM ₁₀ in µg/m ³).	23
Table 4.2	Summary statistics for Arrowtown (PM ₁₀ in µg/m ³).	28
Table 4.3	Summary statistics for Clyde (PM ₁₀ in µg/m ³).	30
Table 4.4	Summary statistics for Cromwell (PM ₁₀ in µg/m ³).	32
Table 4.5	Summary statistics for Central Dunedin (PM ₁₀ in µg/m ³).	35
Table 4.6	Summary statistics for North Dunedin (2005-2007).	37
Table 4.7	Summary statistics for South Dunedin.....	40
Table 4.8	Summary statistics for Milton (PM ₁₀ in µg/m ³).	42
Table 4.9	Summary statistics for Mosgiel from 2005 to 2008.	46
Table 4.10	Summary statistics for Naseby (PM ₁₀ in µg/m ³).	49
Table 4.11	Summary statistics for Oamaru (PM ₁₀ in µg/m ³).	52
Table 4.12	Summary statistics for Ranfurly (PM ₁₀ in µg/m ³).	54
Table 4.13	Summary statistics for Roxburgh (PM ₁₀ in µg/m ³).	56

1. Introduction

Air is one of the important resources in Otago. Good air quality serves as a valuable amenity to the region, generally enhancing the quality of life and promoting good health. On the other hand, poor air quality decreases the quality of life and is associated with many adverse health risks. Poor air quality can also cause “restricted-activity days” when normal outdoor activities may be uncomfortable, affecting tourism and recreation.

Otago residents do enjoy very good air quality in most places during much of the year. However, during colder months increased levels of PM₁₀ (very small particles in the air) are an issue in many towns throughout the region. This is due to higher emissions from solid fuel burners being trapped near the surface when cold, clear weather conditions prevail. Typically, these higher levels of PM₁₀ occur from May to August in most towns. These particles are of concern because they are easily inhaled deep into the lungs. The health effects associated with elevated levels of PM₁₀ range from minor nose and throat irritations, to more serious effects such as aggravation of existing respiratory and cardiovascular disease and, in extreme cases, premature death. Those most at risk include the elderly, the very young, and those with related pre-existing conditions.

In 2004, the Government, concerned with the health effects of air pollution, introduced Air Quality National Environmental Standards (AQNES). They include five standards for ambient (outdoor) air, including sulphur dioxide (SO₂), nitrogen dioxide (NO₂), ozone (O₃), carbon monoxide (CO), and particulates (PM₁₀). Councils are required to monitor for those pollutants which are likely to exceed the standards in their region. Of these five pollutants, only PM₁₀ has been found to be an issue in Otago.

Otago Regional Council (ORC) is responsible for promoting the sustainable management of air quality and maintains a monitoring programme to fulfil its responsibilities under both the Ministry for the Environment’s (MfE) National Environmental Standard and the Otago Regional Plan: Air for Otago (the Air Plan). Prompted by the new standard, ORC upgraded its existing monitoring network and began collecting continuous, daily air quality data in numerous centres around the region.

This State of the Environment Report is a summary and explanation of PM₁₀ monitoring results from 2005 to 2008. Results of earlier monitoring by ORC can be found in the publications, *Ambient Air Quality in Otago, Particulates* (ORC, 2005a) and *Ambient Air Quality in Otago, Nitrogen dioxide, Sulphur dioxide and Carbon monoxide* (ORC, 2005b). Taken together, these reports provide a clear status on air quality in Otago and show where poor air quality has to be improved.

Section 1 provides the background and context for the monitoring and reporting. Section 2 describes the air quality monitoring network and programme in Otago. An Otagowide summary of results is given in Section 3, and Section 4 contains more detailed results on a site-by-site basis. Section 5 examines the trends in air quality at several sites with long-term records. Measures designed to improve air quality to meet the AQNES by the year 2013 are discussed in Section 6.

1.1 Air quality indicators

Air quality can be described in several ways. However, in all cases amounts of PM₁₀ are reported as mass concentrations in units of micrograms per cubic metre of air ($\mu\text{g}/\text{m}^3$).

Three common measures are based on average daily values (24 hours from midnight to midnight). These indicators include:

- The Air Quality National Environmental Standard (AQNES) for PM₁₀ is a nationwide regulation designed to protect human health. The standard sets a 24-hour average of $50\mu\text{g}/\text{m}^3$, with one allowable exceedance during a calendar year. This is to be achieved by 1 September 2013 with steady improvement to that date.
- ORC's Air Plan sets a goal level for particulates of $35\mu\text{g}/\text{m}^3$. The aim is to ensure as much of Otago as possible has ambient particulate concentrations below this level every day.
- High, medium, and low pollution days are often used to categorise each day. A day is considered to be a high pollution day when PM₁₀ levels exceed $50\mu\text{g}/\text{m}^3$; medium when levels are between 35 and $50\mu\text{g}/\text{m}^3$; and low when levels are less than $35\mu\text{g}/\text{m}^3$.

Another useful indicator of overall air quality is the annual guideline set for PM₁₀ by the Ministry for the Environment.

- The annual average of PM₁₀ at each site should be less than $20\mu\text{g}/\text{m}^3$. Like the Otago goal level, this is not a regulation but a target to meet.

These four indicators will be used throughout this report as each offers a different perspective on air quality in Otago. They are shown graphically in Figure 1.1. The various goals and standards are shown with arrows with their corresponding PM₁₀ values on the left (in $\mu\text{g}/\text{m}^3$). High, medium, and low pollution values are shown in colour.

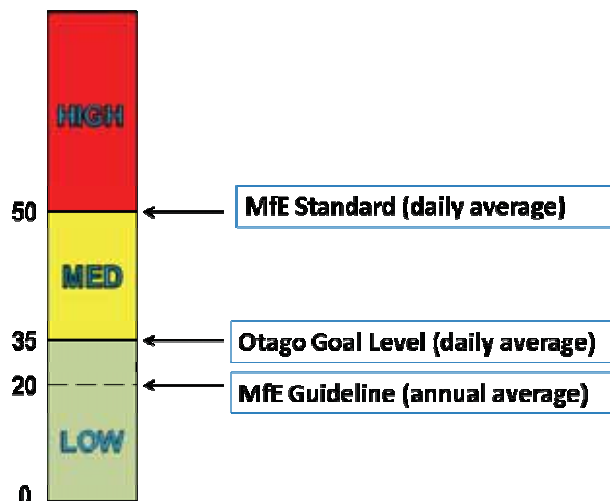

Figure 1.1 Air quality indicators

1.2 Summary results and key findings

AQNES

In terms of the AQNES, an exceedance occurs when the average daily PM₁₀ value is greater than 50µg/m³. Of the 14 sites that have been monitored for PM₁₀ since 2005:

- a significant number of exceedances (more than 30) per year have occurred in each of the following towns: Alexandra, Arrowtown, Clyde, Cromwell, and Milton
- a moderate number of exceedances (between 5 and 10) per year have occurred in Mosgiel, Central and South Dunedin
- few exceedances (less than five) per year have been recorded in Oamaru and North Dunedin
- no exceedances have been experienced in Naseby, Ranfurly, Roxburgh or Lawrence
- Alexandra has the greatest number of days a year over 50µg/m³ (average of 48 days a year). Milton has the second highest average number of days over the AQNES level (46 days a year)

Otago goal level

In comparison to the Otago goal level of every day having PM₁₀ levels less than 35µg/m³, only Naseby (where one winter was monitored) and Lawrence (where monitoring began in mid-August 2008) have achieved the goal.

Roxburgh and North Dunedin each had very few days over the goal. The remainder of towns have all had numerous days over the goal level.

Milton had the greatest percentage of days over the goal level (35% of days).

Annual average guideline

In towns where there is a sufficient length of record to compute an annual average (Alexandra, Arrowtown, Cromwell, Central/North/South Dunedin, and Mosgiel), only Mosgiel, and North and South Dunedin have an annual average less than 20µg/m³.

Notable numbers

- Alexandra has the highest annual average (26µg/m³)
- Alexandra has the highest May-August average (49µg/m³)
- Milton has the second highest May-August average (47µg/m³)
- Arrowtown has the highest one-day PM₁₀ value (168µg/m³)
- Clyde and Cromwell have both had one-day values greater than 100µg/m³

1.3 Monitoring background

Pre-2005

Prior to 2005, the Otago Regional Council collected PM₁₀, SO₂, NO₂, and CO data at various places around the region to determine if, and to what extent, these pollutants existed.

PM₁₀ was sampled on a routine but intermittent basis. Due to the nature of the monitors used, samples could not be taken every day. Instead, they were taken either once every three days during winter months or once every six days during the rest of the year. At the time, this frequency of monitoring was common across much of the country.

There were four monitors operating in the larger centres of Otago, including Alexandra, Central Dunedin, North Dunedin, and Mosgiel. The trend over the years at those sites indicated that high levels of PM₁₀ occurred during winter in Alexandra, Central Dunedin, and Mosgiel. Because of the intermittent sampling schedule, it is very possible that some high pollution days would not have been sampled.

At various times from 1997 to 2004, SO₂, NO₂, and CO samplers were used around Otago at 16 sites. These devices provided average monthly values and were placed in areas where the highest values of those pollutants were expected. Results from this monitoring indicated that these three pollutants are not present in significant quantities in Otago and, therefore, are not likely to pose a problem. Consequently, when the AQNES was introduced, monitoring focused solely on particulates, specifically PM₁₀.

Air Zone designations

To achieve the AQNES, air zones (air quality management areas) were originally designated and gazetted in Otago during 2005. Subsequently, through consultation and refinement, the air zones were revised. The current Air Zones are incorporated into the Air Plan, which became effective on 1 January 2009.

Otago has been divided into three Air Zones. Zones 1 and 2 include 22 urban areas and Zone 3 encompasses the rest of Otago. A set of annual limits for PM₁₀ has been established for most towns. These limits progressively decrease every year until 2013 when the limit is at 50µg/m³. From 2005 to 2013, these limits represent either a straight-line or a curved-line path to compliance. Progress can be measured against these paths (see Section 5 for a detailed discussion). The current air zones are shown in Table 1.1.

Table 1.1 Air zone designations for Otago

Air zone designation	Centres
1	Arrowtown, Alexandra, Cromwell, Clyde
2	Balclutha, Central Dunedin, Green Island, Hawea, Kingston, Milton, Mosgiel, Naseby, North Dunedin, Oamaru, Palmerston, Port Chalmers, Queenstown, Ranfurly, Roxburgh, South Dunedin, Wanaka, Waikouaiti
3	Rest of Otago

Eight continuous monitors are currently deployed around the region. Most are permanent installations; however, several have been used for preliminary screening where previous data were not available. In total, the continuous monitors have been used in 11 locations around the region.

1.4 PM₁₀ and health

The national study - The Health and Air Pollution in New Zealand (HAPINZ) Study

In order to understand the magnitude and nature of the health effects and economic costs associated with air pollution on the population of New Zealand, the Government commissioned a study which was completed in 2007 (Fisher et al. 2007). The latest figures on the health effects from international and New Zealand literature were collected and applied to a national model of annual air pollution concentrations (including PM₁₀). The key findings of this study were:

- Effects associated with elevated PM₁₀ include aggravation of respiratory illnesses and cardio-pulmonary disease and, in extreme cases, premature death.
- The greatest effects are associated with long-term exposure to elevated levels of PM₁₀.
- Adverse health effects can occur at relatively low levels of PM₁₀.
- The most sensitive portions of the population are:
 - a. older people, particularly over-65s
 - b. infants, particularly under-ones
 - c. asthmatics and people with bronchitis
 - d. people with other respiratory problems
 - e. people with other chronic diseases, such as heart disease
- Economically, it is estimated that the increased hospital use due to home heating air pollution costs an individual living in an urban area \$186 per year. This is simply hospital costs, it does not include costs associated with extra doctors visits and extra medicines used.
- There are adverse effects from air pollution that may not have direct and obvious public health implications, but nevertheless affect society. These include restricted-activity days, which can affect large portions of the population on poor, or even moderate, air pollution days and effects on perceptions of poor air quality on tourism and recreation.

A local study - Health Effects of Ambient Air Quality in Otago, New Zealand

A study carried out in 2006 by Public Health South in collaboration with the Otago Regional Council examined the effect of air quality in Otago on hospital admission rates in the region (Goldsmith et al. 2007). Using the existing monitoring data, towns in Otago were categorised into one of four groups based on their number and percentage of high pollution days. Hospital admission rates for respiratory diseases were calculated, standardised, and matched geographically to the four groups.

Results showed that hospitalisation rates for certain respiratory ailments were higher for residents of high air pollution areas than for residents of low air pollution areas. Most affected are the under-five age group; those children living in towns having the highest pollution levels in winter are over two times as likely as those living in low pollution towns to be admitted to hospital with a respiratory complaint.

PM₁₀ - Sources and influences

Otago is a region of varying climates and physical features. Inland, continental climates are known for their temperature extremes of hot, sunny summers and cold, frosty winters. Central Otago towns are commonly located in basins or river valleys. Coastal Otago temperatures are generally more moderate throughout the year. Typically, towns along the sea experience windier conditions than those inland. What inland and coastal communities do have in common, though, is the widespread use of solid fuel burners (wood or coal) for domestic heating.

In every town being monitored, emissions from domestic burners account for the vast majority of PM₁₀ in the air (ORC, 2006). Agricultural burn-offs and industrial emissions also contribute to elevated levels of PM₁₀. Two main factors influencing the amount of PM₁₀ in the atmosphere are: emissions (rates and types) and atmospheric mixing.

For most of the year, residents of Otago experience very good air quality. However, in several towns during the colder months (May to August), air quality can be sub-standard. This is frequently due to the occurrence of temperature inversions at night trapping pollutants at the surface. This important feature is described below.

What is a temperature inversion?

Most days, the sun warms the surface of the Earth which, in turn, warms the air above it. Warmer air is less dense than cold air; think of a hot air balloon – when filled with hot air, the balloon rises. Because of this, the warm, lighter air near the surface is able to rise and mix with the cooler air above. This situation is known as “*unstable*” and helps disperse any pollutants into the atmosphere.

A temperature inversion occurs when the air next to the surface is colder than the air above it. This often happens on a cold, clear night when the Earth’s surface cools rapidly, cooling the air right above it. This cold air next to the surface is heavier than the warmer air above and so can’t mix with it. This is known as a “*stable*” atmosphere. Any smoke or other pollutants that go into the air during the night stay near the surface where they remain till the inversion layer breaks up in the morning once the ground starts to warm again.

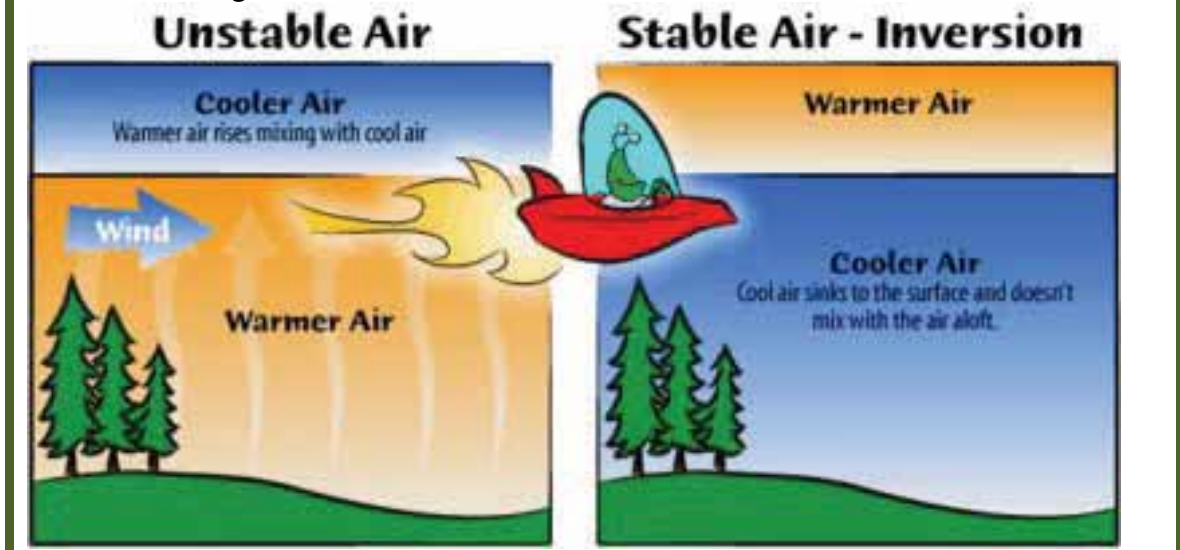

Temperature inversions occur anywhere in Otago but are most common in Central Otago, usually forming under clear skies when there is not much wind. Also because many Central Otago towns are surrounded by large hills, it is likely that during the night, cold air sinks down from the hills and ends up making air in the town even colder and the inversion layer stronger than in other towns.

2. Monitoring programme

2.1 Establishment of the AQNES monitoring network

The AQNES requires that towns where the standard is likely to be exceeded be monitored continuously. In addition, the monitor should be located in the area of town where pollution levels will be most significant. This may be where levels are expected to exceed the $50\mu\text{g}/\text{m}^3$ limit either the most frequently or by the largest margin.

Over the past four years, continuous PM_{10} monitoring has occurred in varying durations in the following areas: Alexandra, Arrowtown, Cromwell, Clyde, Ranfurly, Naseby, Roxburgh, Central Dunedin, Mosgiel, Oamaru, and Milton. In addition, intermittent sampling has been done in North and South Dunedin and in Lawrence.

Specific sites within each of these areas were chosen in accordance with Australia and New Zealand Standards: Guide to Siting Air Monitoring Instruments (ASNZS, 1987, 2007). These standards set out the requirements for proper placement of air quality monitoring instruments. While there are several considerations in locating an appropriate site for a monitor, certainly one of the most important features of this standard is that the PM_{10} sampling head have a minimum sky angle of 120 degrees. This is depicted in Figure 2.1.

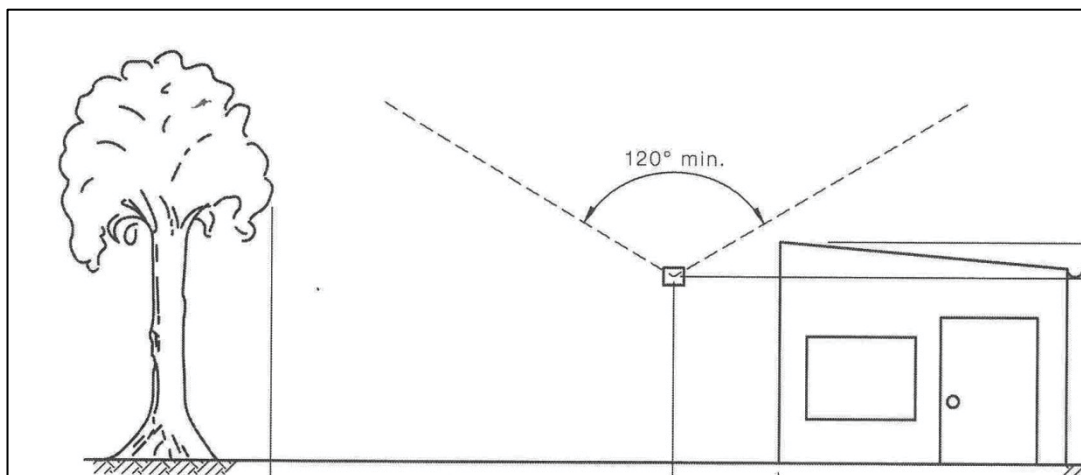

Figure 2.1 Ideal exposure of 120° from PM_{10} sampling point

It may not always be possible to meet every objective of the standards, however, every effort is made to do so. Other considerations include: accessibility to mains power, land owner cooperation, and public safety.

2.2 Sampling methods

ORC uses two very different types of technology to monitor ambient PM_{10} levels in the Otago region, both of which are recognised MfE and US Environmental Protection Agency (USEPA) methods. Each type is capable of yielding a 24-hour (midnight-to-midnight) daily average value of PM_{10} .

Intermittent samplers

A gravimetric high-volume sampler passes air through an A4-sized filter paper where PM₁₀ particles are deposited. The filter must be changed and the unit programmed for each sample day, making this system fairly labour-intensive. The clean, pre-exposed filters have been weighed and are then re-weighed after 24 hours of sampling. The difference in mass is then used in conjunction with the volume of air that has moved past the filter to determine a mass concentration for the day. This had been the standard method of measurement in Otago since 1997 and today two such samplers remain active.

The four exposed filters shown in Figure 2.2 indicate a range of daily PM₁₀ levels in Lawrence during August 2008. Note that despite the obvious discoloration, none of these samples produced a result greater than 50µg/m³.



Figure 2.2 Four filters from an intermittent high-volume monitor with daily samples taken in Lawrence during September 2008. Values (in µg/m³) are shown for each

Continuous samplers

With the introduction of the AQNES, continuous sampling was required to ensure that every day was being evaluated. Newer, more sophisticated methods and samplers were, therefore, employed. ORC uses beta attenuation monitors (BAM) to accomplish this monitoring.

The similarity to the older machines is that a known volume of air is passed through a small filter where PM₁₀ particles are deposited. However, the measurement method is completely different. At the beginning of every hour, a source of beta rays passes high-energy electrons through a portion of clean filter where they are detected and counted. After sampling, this exposed portion of the filter tape is again subject to the same source of beta rays. The PM₁₀ on the filter will attenuate the beta ray signal as compared to the first, clean measurement and that difference, along with the known volume of air which has been pumped past the filter, is used to calculate the concentration of particulate in the ambient air. The hourly PM₁₀ readings are then converted to average daily values (midnight-to-midnight). Figure 2.3 shows the hourly samples from a beta monitor.

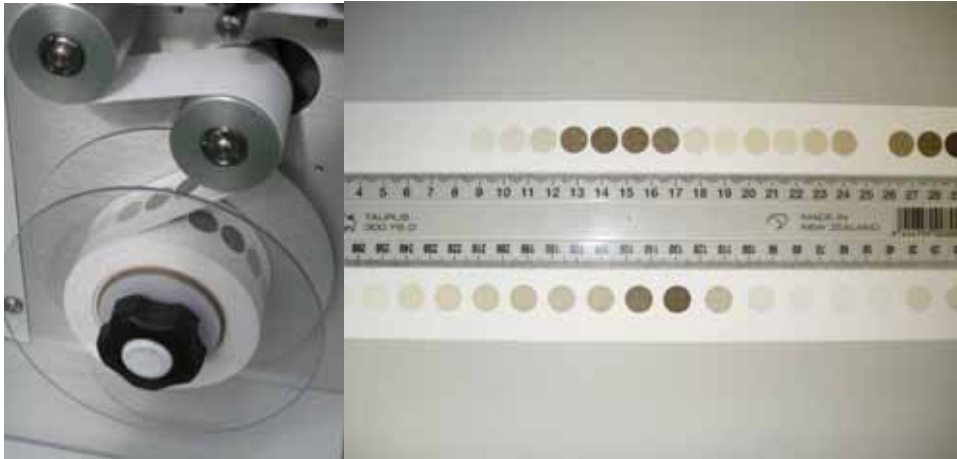

Figure 2.3 Examples of exposed filters from a BAM monitor. Each circle represents one hour of sampled PM₁₀

Monitor locations

During the period from 2005 to 2008, PM₁₀ monitoring took place at 14 sites throughout Otago. ORC follows the New Zealand convention of site classification which is based on international standards. The purpose of site classification is to define emission characteristics of a site. Classification also allows comparison of datasets nationally.

Sites are classified into broad categories which include the following: traffic, industrial, residential, and special. Since the majority of Otago's pollution problem is a result of solid fuel burning for domestic heating, all sites fall within the residential category. Within that group, there are two sub-groups: neighbourhood and peak. A neighbourhood site encompasses representative suburban and small town residential areas. A peak sub-group may also be located in a residential area but will include some industrial/commercial activity as well. This is the case in Central and South Dunedin as well as the Mosgiel site. All of the sites are considered ambient sites in that they do not specifically target any particular source of emissions.

Table 2.1 lists the sites, the type of monitor used, and each site's monitoring classification. Figure 2.4 is a map of the sites.

Table 2.1 PM₁₀ monitoring sites with their characteristics and sampling frequencies

Site	Type of monitor	Sampling frequency	Site classification
Alexandra	BAM	Daily	Neighbourhood
Arrowtown	BAM	Daily	Neighbourhood
Clyde	BAM	Daily	Neighbourhood
Cromwell	BAM	Daily	Neighbourhood
Central Dunedin	BAM	Daily	Peak
North Dunedin	High volume	1-in-3, 1-in-6 day	Neighbourhood
South Dunedin	High volume	1-in-3, 1-in-6 day	Peak
Lawrence	High volume	1-in-3, 1-in-6 day	Neighbourhood
Milton	BAM	Daily	Neighbourhood
Mosgiel	BAM	Daily	Peak
Naseby	BAM	Daily	Neighbourhood
Ranfurly	BAM	Daily	Neighbourhood
Roxburgh	BAM	Daily	Neighbourhood
Oamaru	BAM	Daily	Neighbourhood

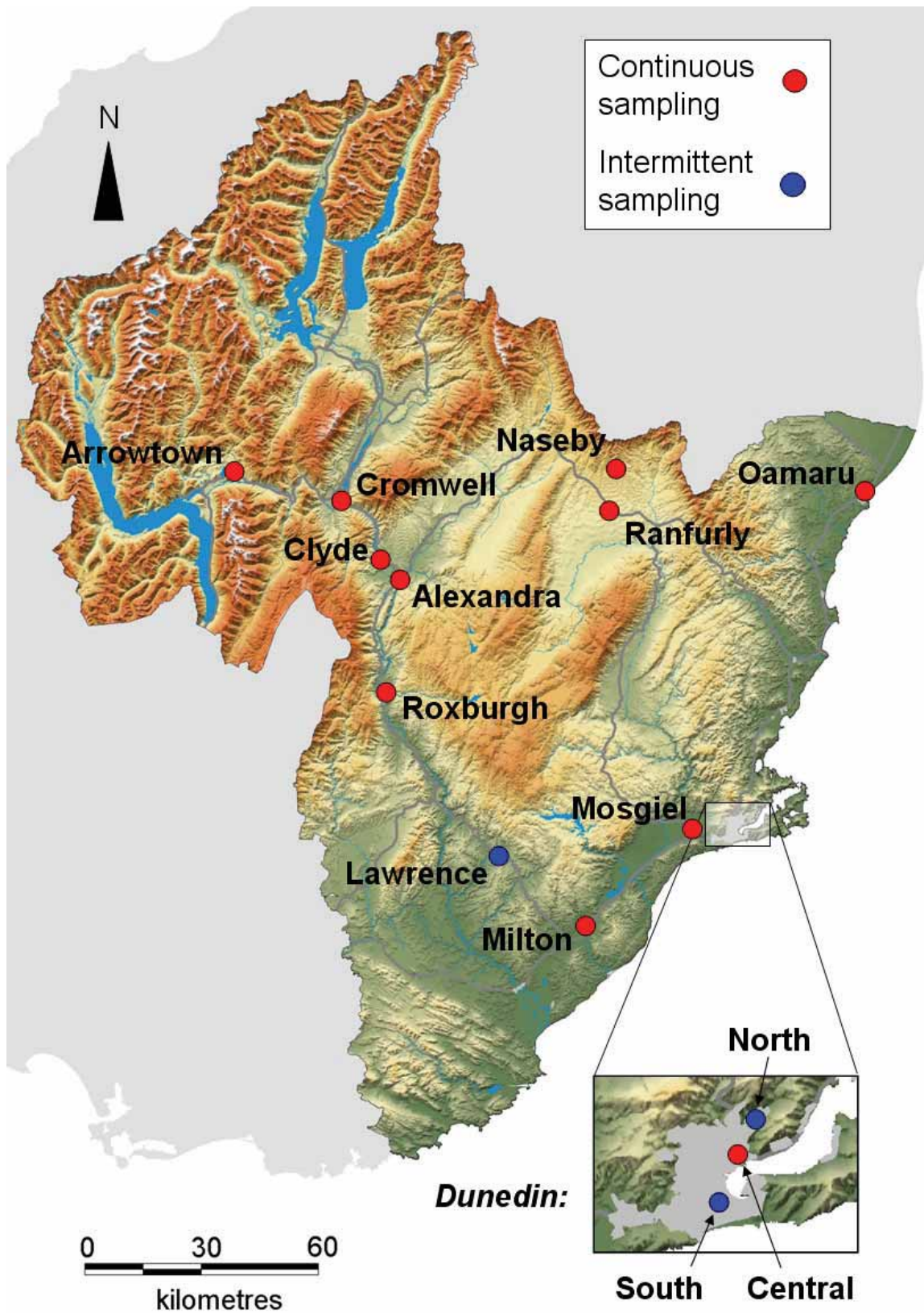

Figure 2.4 Otago map showing the locations of all monitoring sites from 2005 to 2008

Not every site has been monitored since 2005. In some instances, monitors were installed and run for one or two winter seasons. This seasonal monitoring was for screening purposes in towns where only limited data had previously existed. Figure 2.5 indicates when monitors were operational at the various sites.

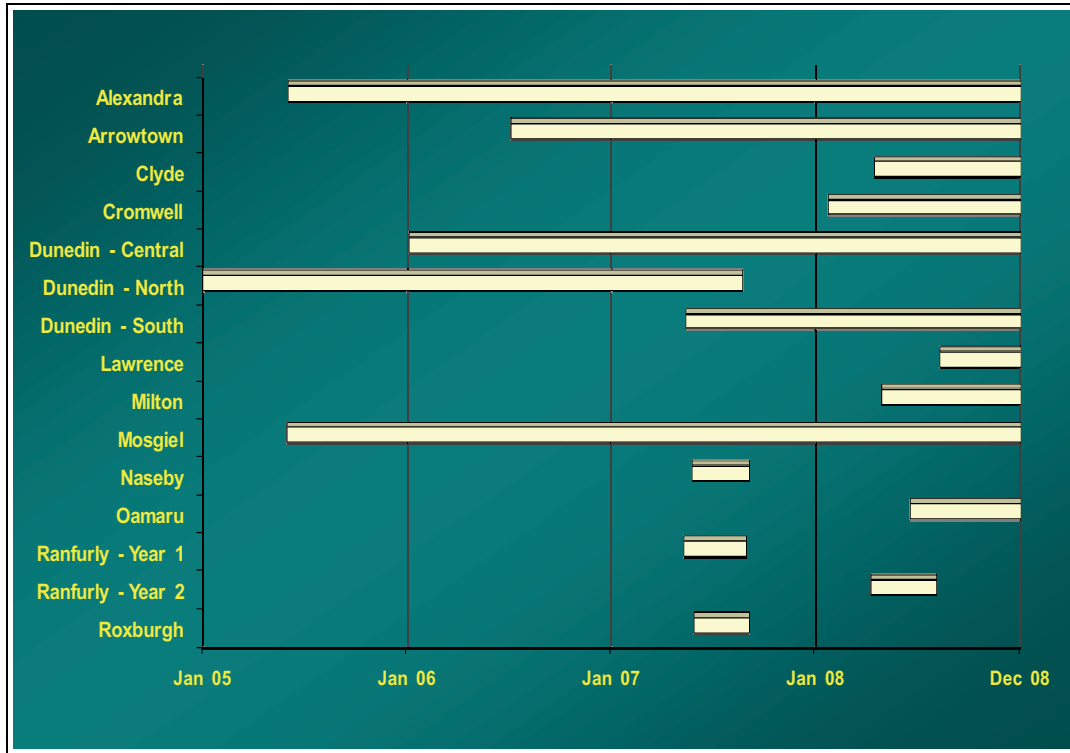

Figure 2.5 Timeline showing when PM₁₀ monitors were active at each site. Sites where the bar extends through to December 2008 are currently active

A typical continuous monitoring site is shown in Figure 2.6. Along with PM₁₀, most continuous sites collect hourly air temperature and wind (speed and direction) data.



Figure 2.6 A typical continuous beta monitoring site

3. Summary of results – Otagowide

This section provides an overview of PM₁₀ monitoring results around the region from 2005 to 2008. Summary statistics relative to the AQNES, the Air Plan, and air quality categories are presented for the 14 (11 continuous, 3 intermittent) monitored sites during this period. Averages (seasonal and annual), maximums, and the number of high pollution days are examined and some important regional differences are noted.

3.1 Annual and summary statistics

Looking at the annual averages, sites range between 13 and 26 µg/m³. Figure 3.1 shows that Cromwell falls just on 20 µg/m³ while Mosgiel, North and South Dunedin are the only sites with annual averages of less than 20 µg/m³. Alexandra, Arrowtown, and Central Dunedin all have annual averages greater than the MfE guideline of 20 µg/m³.

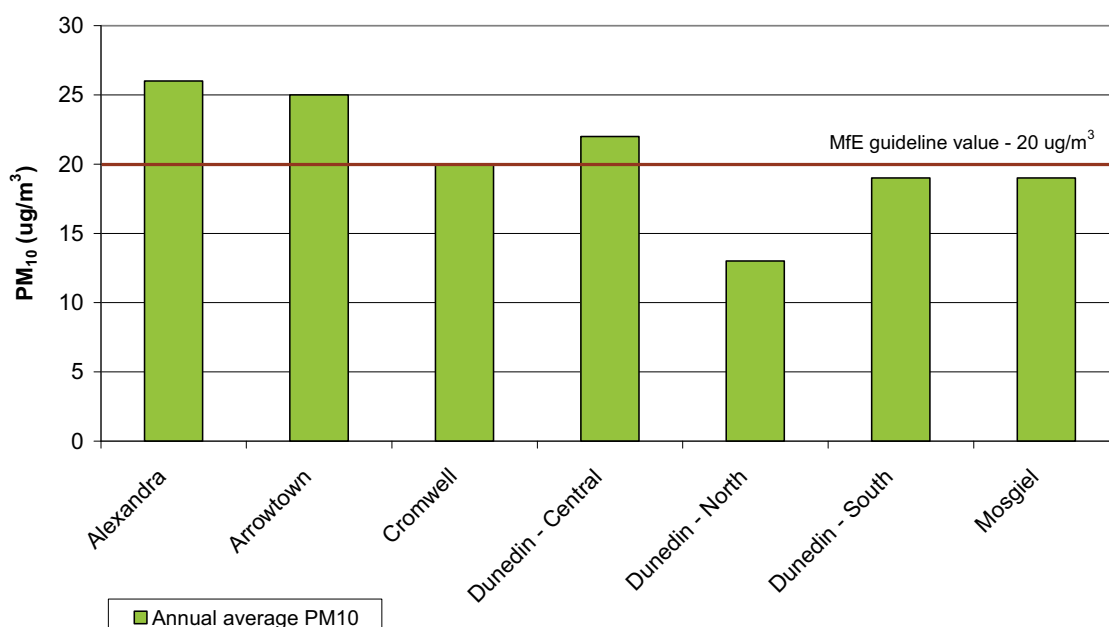

Figure 3.1 Annual average PM₁₀ values. (To compute an annual average, 274 out of 365 days must be sampled, or 75% of the year. Some of the 14 sites were only monitored during the colder months of the year and others have been out of service for lengthy periods; those sites have not met the 75% criteria)

While these results look quite similar, they are only one indication of the overall air quality in Otago. Because the physical conditions are so different around the region, it's not surprising that air quality in Otago varies widely not only between towns but between seasons as well. A summary of statistics is given in Table 3.1. The largest numbers in each category are highlighted.

Table 3.1 Summary statistics for PM₁₀ monitoring sites in Otago 2005-2008

Site	Year	Annual average PM ₁₀	May-August average	Maximum daily value	Number of high pollution days (annual average)	% days over Otago goal level
Alexandra	2005-2008	26	49	150	48	25
Arrowtown	2006-2008	25	45	168	32	22
Clyde	2008	-	40	104	39	26
Cromwell	2008	20	37	109	32	17
Dunedin - Central	2005-2008	22	25	86	6	10
Dunedin – North	2005-2007	13*	16*	52*	1**	1
Dunedin – South	2007-2008	19*	22*	64*	5**	5
Lawrence	2008	-	-	31*	0	0
Milton	2008	-	47	141	46	35
Mosgiel	2005-2008	19	24	108	8	9
Naseby	2007	-	14	33	0	0
Oamaru	2008	-	22***	54	3	6
Ranfurlly	2007-2008	-	21	46	0	13
Roxburgh	2007	-	16	36	0	1

NOTES:

PM₁₀ values are micrograms per cubic metre of air

Annual and winter averages are only given where >75% of time period sampled

* from intermittent monitoring

** corrected for one day in three monitoring schedule

*** only 64% of winter period measured

Approximately one-third of all days monitored in Milton are either medium or high pollution days. All four of the towns in Central Otago exhibit a large proportion of high pollution days as well. Arrowtown had the highest one-day reading of 168µg/m³ and Alexandra has the highest annual average of 26µg/m³ and the greatest number of high pollution days on average (48 days a year).

Ranfurly, Roxburgh, and Naseby – all of which were monitored during winter months – recorded no high pollution days. Lawrence has only been monitored for part of one winter so far.

3.2 Seasonal differences

To compare the colder part of the year, when emissions from solid fuel burners are at their highest, with the rest of the year, it is helpful to separate out the months from May to August from the rest of the year. Figure 3.2 shows the average daily PM₁₀ values for all monitoring sites for these two parts of the year: May-August (green bars) and the rest of the year (striped green bars). At every site, an average winter's day always has higher PM₁₀ levels than an average day during the rest of the year. This seasonal difference is most pronounced in Alexandra, Arrowtown, Clyde, Cromwell, and Milton.

For months outside the May-August period, Central Dunedin has the highest overall daily average with 20µg/m³ and Cromwell has the lowest (9µg/m³).

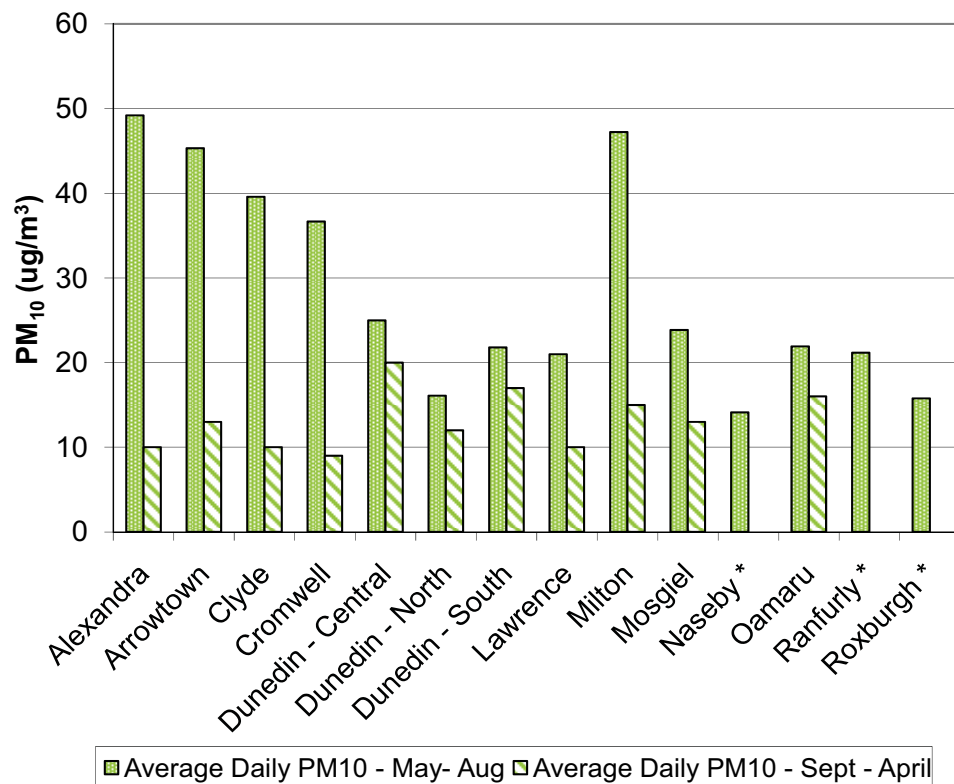

Figure 3.2 An inter-seasonal comparison of average daily PM₁₀ values across Otago. The green bars represent the average day's value from May to August. The striped bars indicate the average day's value over all other months of the year

* Naseby, Ranfurly, and Roxburgh were only monitored from May to August.

3.3 Category frequencies

Another useful indicator of overall air quality at a site is how often days fall into a particular air quality category. A day can be classified as having either high (greater than $50\mu\text{g}/\text{m}^3$), medium ($35\text{-}50\mu\text{g}/\text{m}^3$), or low (less than $35\mu\text{g}/\text{m}^3$) pollution. The frequency of each category is shown in Figure 3.3.

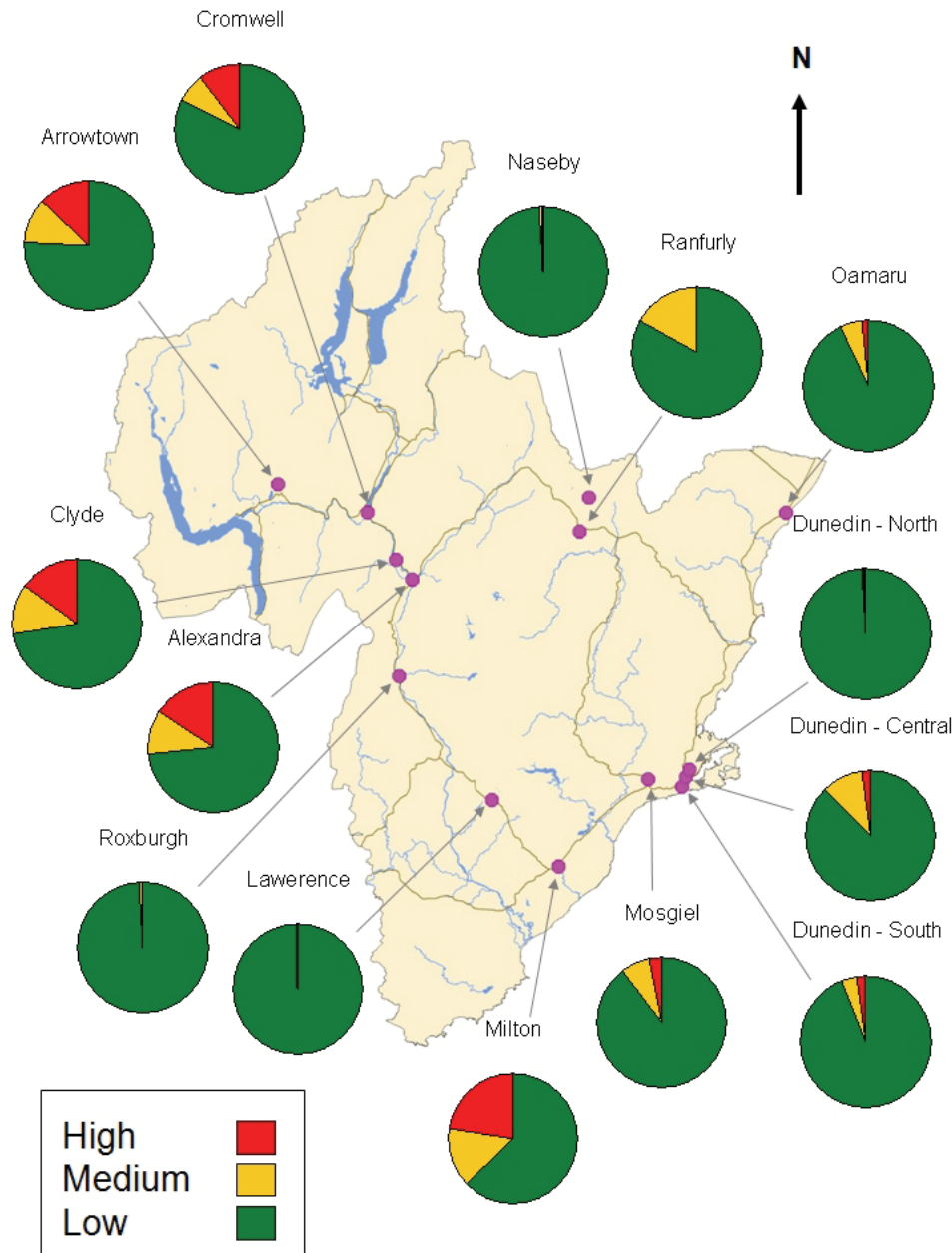

Figure 3.3 Proportions of days that were high, medium and low pollution days in the 14 centres monitored from 2005 to 2008. Note some monitors (Roxburgh, Naseby, Ranfurly) were only run over the winter months when PM_{10} levels are higher so they will show higher proportions of medium pollution days than others

3.4 Regional differences

A box plot is helpful to illustrate contrasts that can occur in air quality trends around the region.

How to read a box plot

Box plots provide a very useful and visual summary of five important numbers in a dataset: the maximum and minimum values, the median value (half the days lie above this value, and half below), and the 25% and 75% levels (one quarter of all days fall below the 25% level, one-quarter lies above the 75% level).

In the example, all the days from January to June are shown together in one box plot. The maximum value recorded is 91, the minimum is three. The median value is 17; half the days sampled have PM₁₀ values higher than this, and half are below 17.

At a glance, it is easy to see that half of all sampled days have PM₁₀ values from about 9 to 28 µg/m³ (the bottom and top of the box).

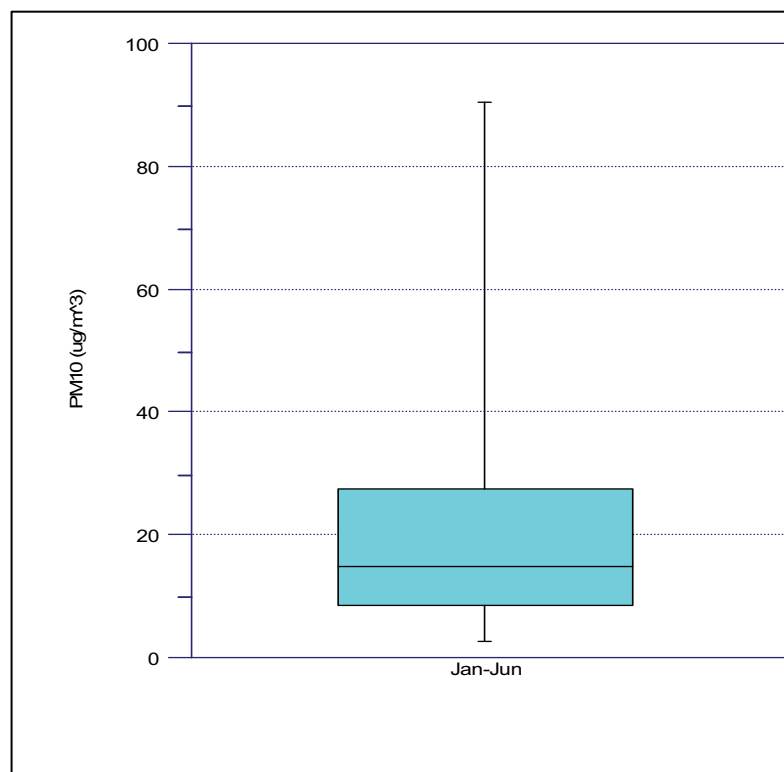

Figure 3.4 represents a three-season breakdown of PM₁₀ at Alexandra and Central Dunedin. A distinct seasonal difference of PM₁₀ is obvious in Alexandra. During the winter months of May to August, the median is substantially higher than during the other two seasons, indicating that more days have higher values during the colder months. The maximum value occurs from May to August. There is also a greater variability from May to August than the rest of the year, represented by the substantially larger box.

In Dunedin, on the other hand, there is an obvious similarity between the medians during each period of the year. As in Alexandra, the maximum occurs during the winter. However, across the three periods, days generally fall within the same range (indicated by the boxes being about the same size around the $20\mu\text{g}/\text{m}^3$ mark).

The reasons for this difference will be discussed in more detail in the following section, but this serves as an important reminder that while sites may have overall trends in common, each site will have its own pollution signature resulting from its unique emission and meteorological influences.

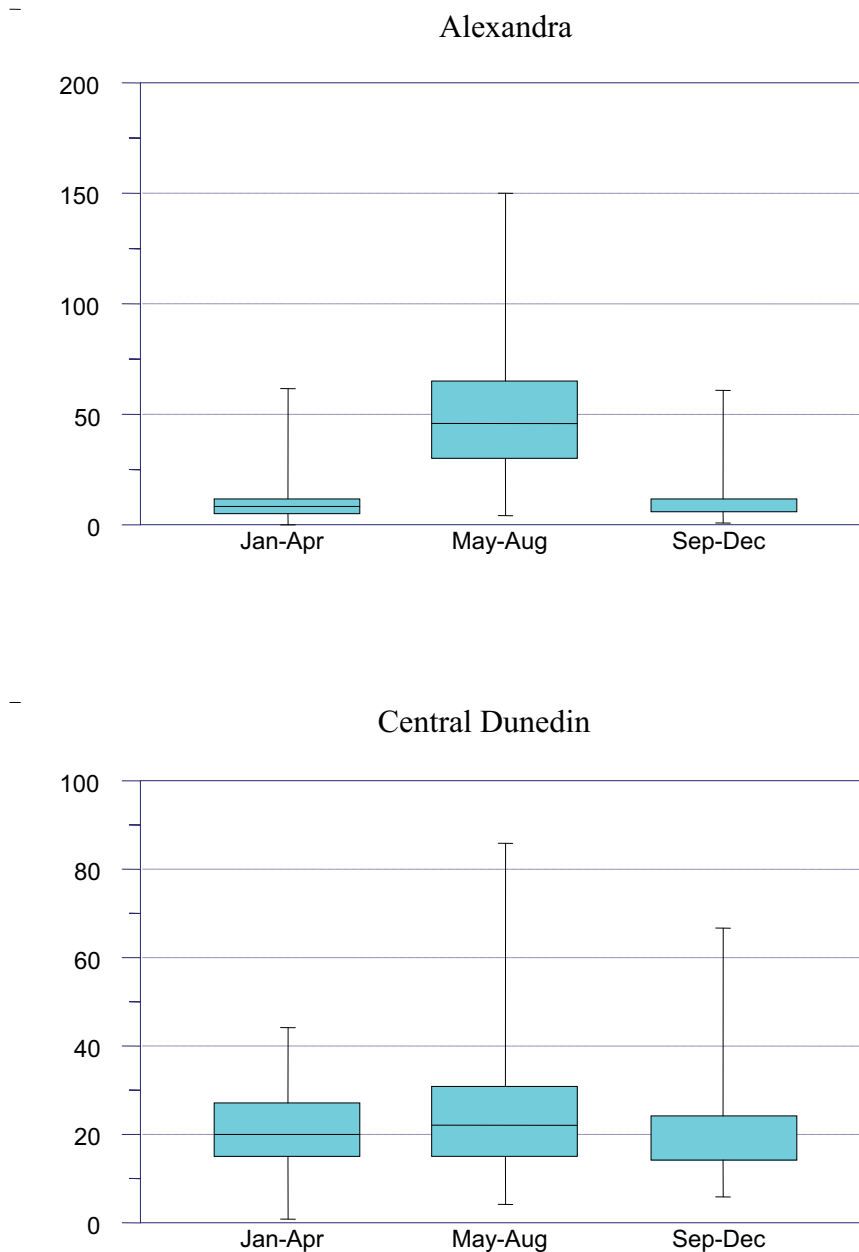

Figure 3.4 Three-season box plots of Alexandra and Central Dunedin. The scale on the left is PM_{10} in $\mu\text{g}/\text{m}^3$

It's clear from the summary statistics presented in this section that the four Central Otago towns (Alexandra, Arrowtown, Clyde, and Cromwell) and Milton experience the highest levels of PM₁₀ during the colder months from May to August. Exceedances of the AQNES and of the Otago goal level occur regularly during colder months in many towns.

This section has provided an overview of the region and presented some of the differences in air quality between towns and between seasons. The following section discusses results of monitoring on a site-by-site basis, providing more detail about the nature of the air quality at each site.

4. PM₁₀ results: individual sites

This section provides site-by-site summaries of the air quality data collected in Alexandra, Arrowtown, Clyde, Cromwell, Ranfurly, Naseby, Roxburgh, Oamaru, Dunedin (North, Central, and South), Mosgiel, Milton, and Lawrence from 2005 to 2008. While many of the sites exhibit similar trends and values, it is important to remember that each site is geographically distinct and will have its own unique set of factors which directly influence PM₁₀ levels.

4.1 Alexandra

Alexandra has one of the longest continuous PM₁₀ records in Otago, beginning in June 2005. Summary statistics provided in the previous section indicate that winter time air quality is regularly poor. In an effort to understand more about the nature of Alexandra's air quality issues, special studies have been done on two topics: monitoring the strength of the inversion layer and its relationship to PM₁₀ levels, and an examination of potential transport of particulates between Alexandra and Clyde. This section provides an explanation of the ambient PM₁₀ monitoring and the findings of these studies.

Prior to 2005, Alexandra had been monitored intermittently since 1997. Results of that monitoring can be found in the *Ambient Air Quality in Otago 1997-2004* report (ORC, 2005a). Results of the continuous monitoring are shown in Figure 4.1 and Table 4.1.

Alexandra exhibits an obvious pattern of having very high levels of PM₁₀ during winter months and relatively low levels during the rest of the year.

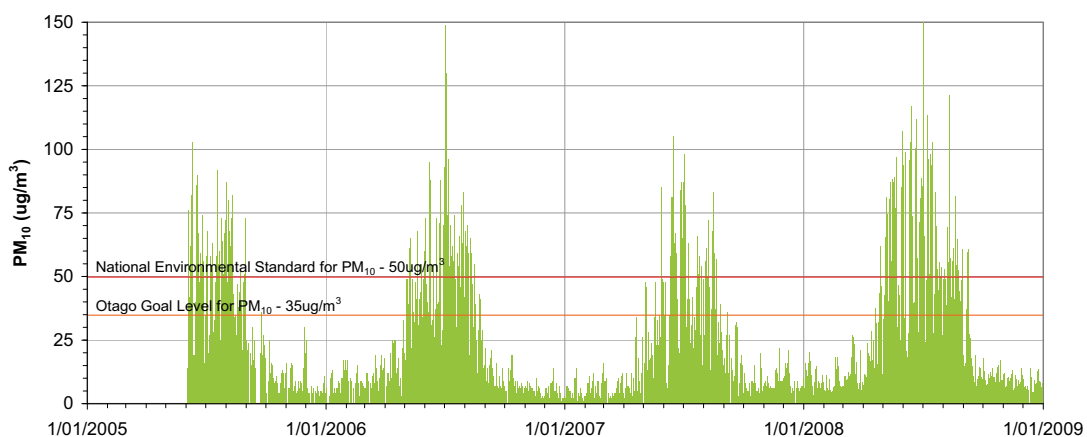

Figure 4.1 Daily PM₁₀ values for Alexandra from 2005 to 2008

For each year where comparisons can be made to other sites, Alexandra has recorded the highest number of days with average PM₁₀ levels greater than 50 µg/m³. Winter averages for these four years have ranged from 39 µg/m³ to 60 µg/m³ and maximum daily values each year have been greater than 100 µg/m³.

Table 4.1 Summary statistics for Alexandra (PM₁₀ in µg/m³)

	Annual average	Maximum and second-highest daily values	Number of high pollution days (>50µg/m ³)	May-Aug average
2005	32*	103 / 92	42	50
2006	22	149 / 130	39	47
2007	19	105 / 98	35	39
2008	29	150 / 122	75	60
Average	26	127 / 111	48	49

* from intermittent monitoring

Figure 4.2 depicts the monthly norms for Alexandra. Traditionally, air quality issues have been associated with the winter months of June, July, and August. However, it seems apparent that in terms of PM₁₀ levels, May is also significant. The maximums and means are quite similar to those found in August, and certainly the majority of days exhibit elevated PM₁₀ levels. April and September appear to be the shoulder months, indicating both the beginning and end of the high particulate season. For the remainder of the year, PM₁₀ is relatively low.

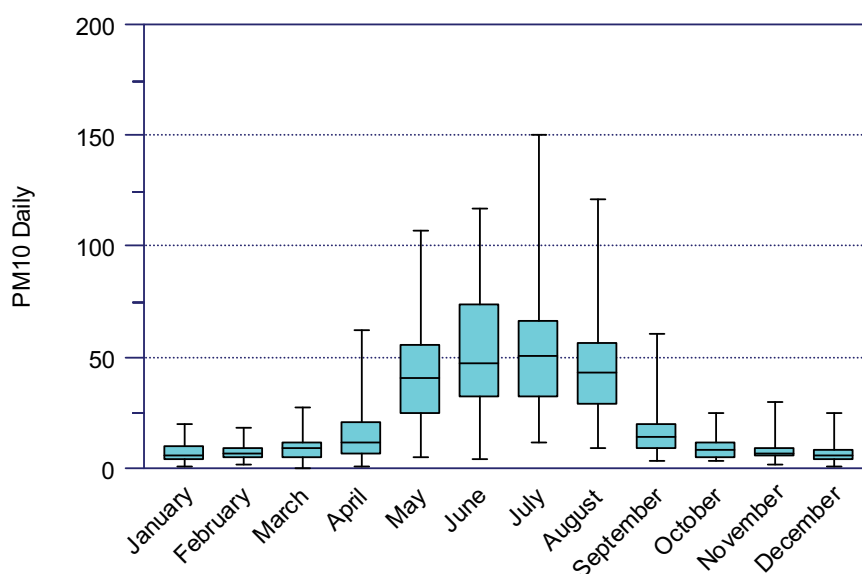

Figure 4.2 Box plots of monthly summary values for Alexandra (June 2005 – December 2008)

According to the latest Emissions Inventory (ORC, 2006), 99% of particulate emissions in Alexandra come from solid fuel burners used for domestic heating. On a typical winter’s day, particulate emissions are estimated to be approximately 380kg. Alexandra’s unique geographic setting definitely affects what happens to those particulates throughout the day, particularly over the colder months. The town is situated in a sheltered basin in Central Otago.

It experiences a continental climate characterised by temperature extremes in summer and winter. Temperature inversions are common occurrences throughout winter months,

servicing to trap particulate-laden cold air near the surface overnight and into the morning hours. An average day's PM₁₀ hourly values, shown in Figure 4.3, exhibits that trend. The difference between the summer and winter diurnal trend is pronounced.

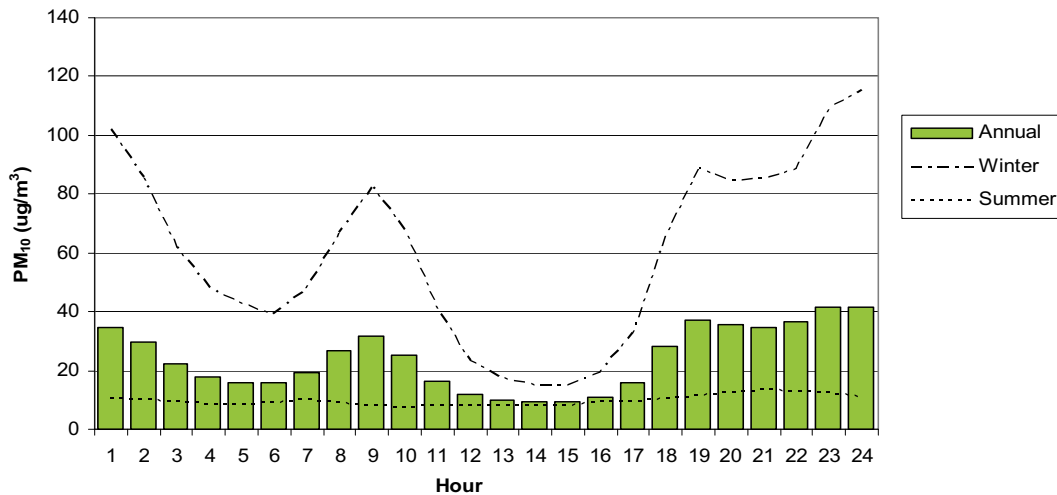

Figure 4.3 Average hourly concentrations of PM₁₀ in Alexandra depicted for: All the data, Winter months (May-August), and Summer months (December-March)

Trends in Alexandra's air quality

The monitor in Alexandra is located along Ventry Street in a typical residential section of the town. Emissions are almost exclusively from domestic solid fuel burners. Monitoring began in 1997 with an intermittent hi-vol sampler and after two years of overlap between the two, currently continues with a continuous BAM monitor.

The graph in Figure 4.4 depicts annual average, May-August average, and September-April PM₁₀ levels. None of the graphs show a clear trend. Except for the spring/summer/autumn months, values are well above those that would meet AQNES and Otago requirements.

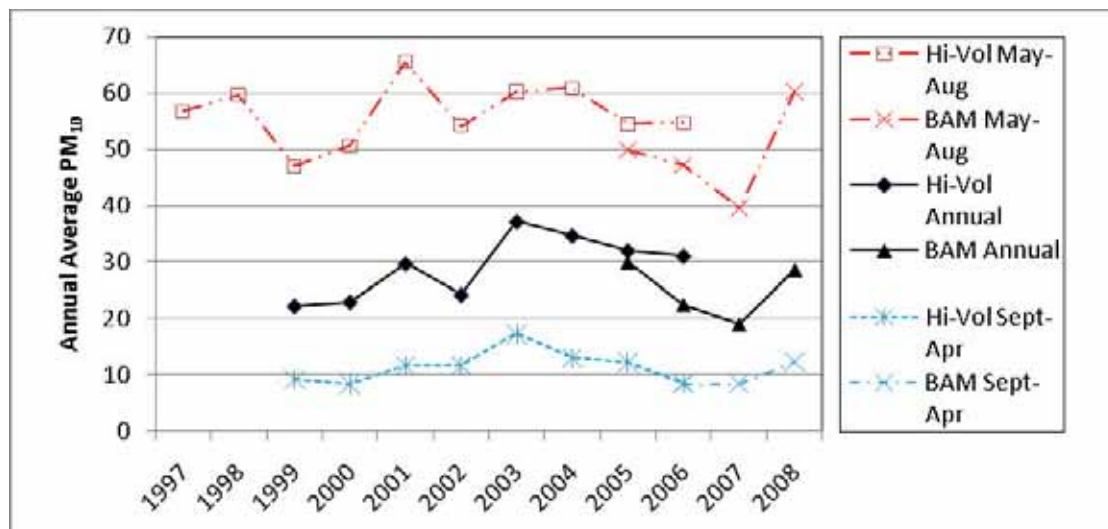

Figure 4.4 Trends in PM₁₀ air quality at Alexandra from 1997 to 2008

Temperature inversion study

Our air quality reports often make reference to temperature inversions contributing to increased particulate levels during winter months in Central Otago. By definition, an inversion exists when air temperature increases with increasing height above the Earth's surface. This often occurs overnight when skies are clear and the surface has cooled significantly, cooling the air directly above the ground. (See Section 3 for an explanation).

In an effort to understand more about this phenomenon, the ORC (in conjunction with a University of Otago student), installed five Hobo temperature sensors up a steep hillside in Alexandra at the start of winter. The placement of the sensors reasonably replicates the increasing height in the atmosphere.

By looking at the difference in temperature between sites at different elevations, we can see how strong the inversion layer was on any given night and how long it lasted. When the temperature at the ORC site in Ventry Street is colder than that at the highest Hobo (Hilltop), there is a temperature inversion. Figure 4.5 shows the temperature at these two sites over two days during winter 2008. On these days, the inversion formed around sunset and lasted until mid-morning, a typical pattern when the sky is clear in Central Otago.

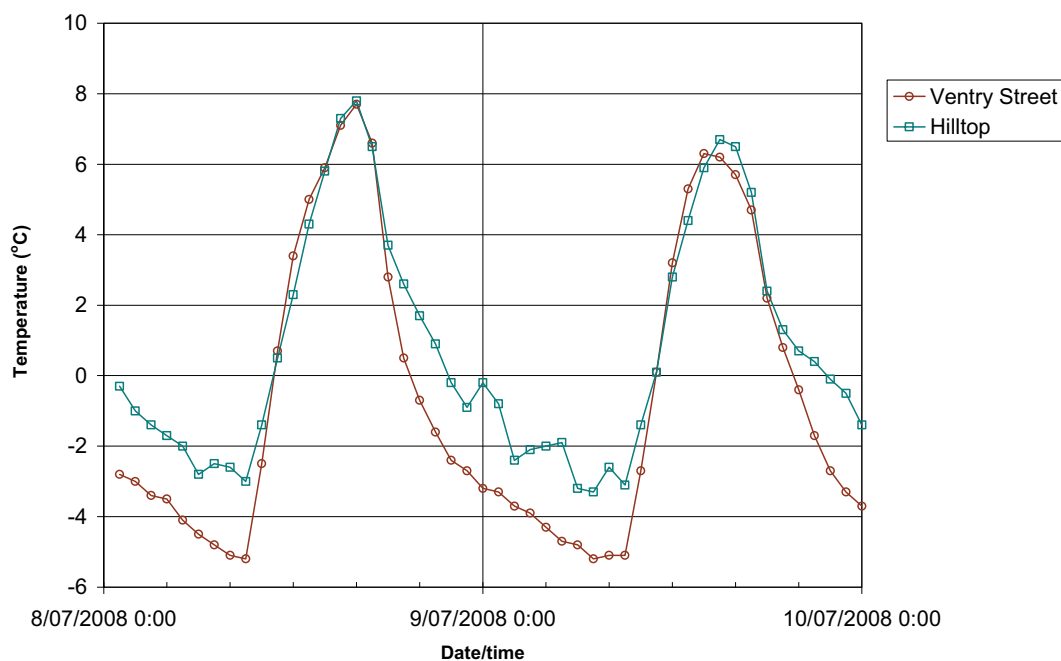

Figure 4.5 Average hourly temperature at Ventry Street and on the Hilltop measured on 8-9 July 2008

It is often difficult to comment on air quality trends over the years because air quality is so influenced by the weather from one year to the next. However, to evaluate whether measures designed to reduce emissions are working this must be addressed. If we know the amount of air pollution we would expect in conjunction with an inversion, and we monitor the occurrence of inversions then we may be able to use this information to determine whether the air quality in Alexandra is improving.

Figure 4.6 shows that when the inversion layer is more intense the day is more likely to experience high air pollution levels. While this is common sense, being able to quantify the number of inversion days means we should be able to compare PM_{10} more meaningfully in years to come.

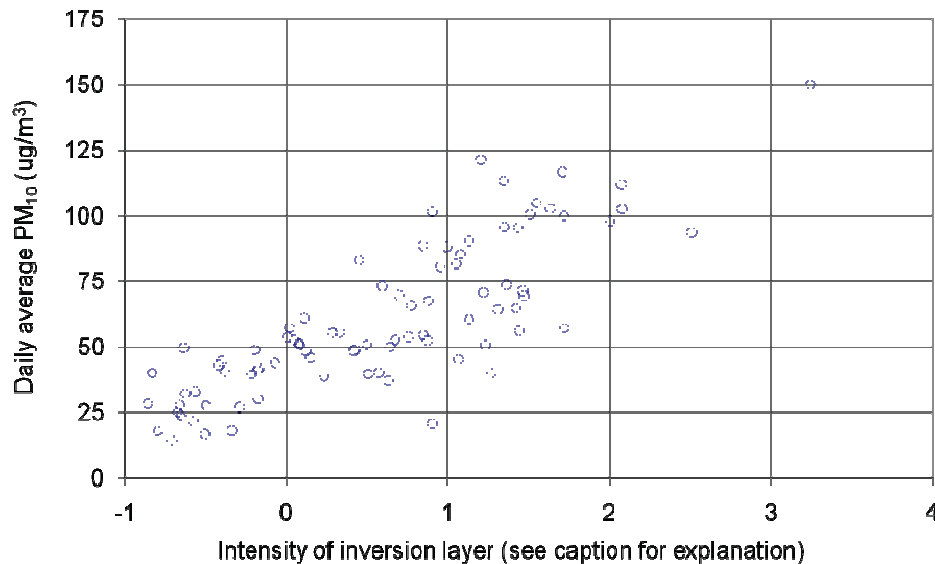

Figure 4.6 Scatter plot of daily average PM_{10} and the intensity of the inversion layer during winter 2008. The intensity of the inversion layer here is taken to be the average temperature difference between the top temperature logger on the hill and at the ORC monitoring station in Ventry Street. The higher the number, the stronger the inversion

Examination of PM_{10} transport between Clyde and Alexandra

An investigation into the interaction of PM_{10} emissions between Clyde and Alexandra was made owing to interest in whether emissions from Clyde affect PM_{10} levels in Alexandra (ORC, 2009a). The investigation focused on understanding the wind patterns occurring during high pollution days as these are the primary indicator of transport of PM_{10} .

Results show that there is little evidence that significant concentrations of PM_{10} are transported between the two towns. Computer modelling of the atmosphere and PM_{10} in the Alexandra Basin showed that less than $0.1\mu g/m^3$ of the PM_{10} concentrations accumulating in Clyde and Alexandra originated in the other town. This equates to under 0.1% of the PM_{10} in each town being from the other town.

In addition, wind observations from three sites in the basin do not show any consistent wind direction during high pollution days (necessary if regular transport of PM_{10} was occurring), but do show predominantly low wind speeds (<1.0 m/s). One additional site set up by Otago University at the Alexandra Golf Course between Clyde and Alexandra shows predominantly southerly wind direction, which is the opposite from that expected if PM_{10} was to be transported down the valley from Clyde to Alexandra.

There had also been a theory suggesting that the dual evening peak of PM_{10} seen in Alexandra (See Figure 4.3) is initially from Alexandra and then from air transported

from Clyde. However, further examination showed that, rather than a second peak, the monitor experiences large dips in PM_{10} in the mid-evening from clear air being moved past the monitor.

The wind observations do point to two processes occurring on high pollution days:

- cold-air drainage winds from the hills surrounding the basin
- formation of a cold-air pool or pond in the valley floor as these winds converge

The cold-air pond has the effect of separating the basin floor from the wind above and causes low wind speeds and conditions conducive to high PM_{10} levels even when frontal systems etc clear the air at the surface of other towns. This makes it all the more important to reduce emissions of PM_{10} from solid-fuel heating in the towns as they are far more susceptible to high PM_{10} levels than other towns in Otago.

A study by the University of Otago's Geography Department noted that high pollution days occur in Alexandra under a variety of synoptic weather conditions (West, 2008). Even when higher wind speeds (that would disperse PM_{10}) were expected, the lower atmosphere remained stable and PM_{10} remained high. This points to the formation of a cold air pool on nights with high pollution levels.

Cold air drainage winds and cold air pools

One important process that occurs during the night in mountainous areas is the formation of cold-air drainage winds. These winds (or flows) occur because areas at higher elevations cool rapidly and sink down the hills into the valleys and basins below. In basins where there is no low lying exit this can result in a cold air pool or lake. In this, the entire valley floor is covered in a blanket of cold air that effectively separates the valley floor from any winds above it, as shown in Figure 4.7.

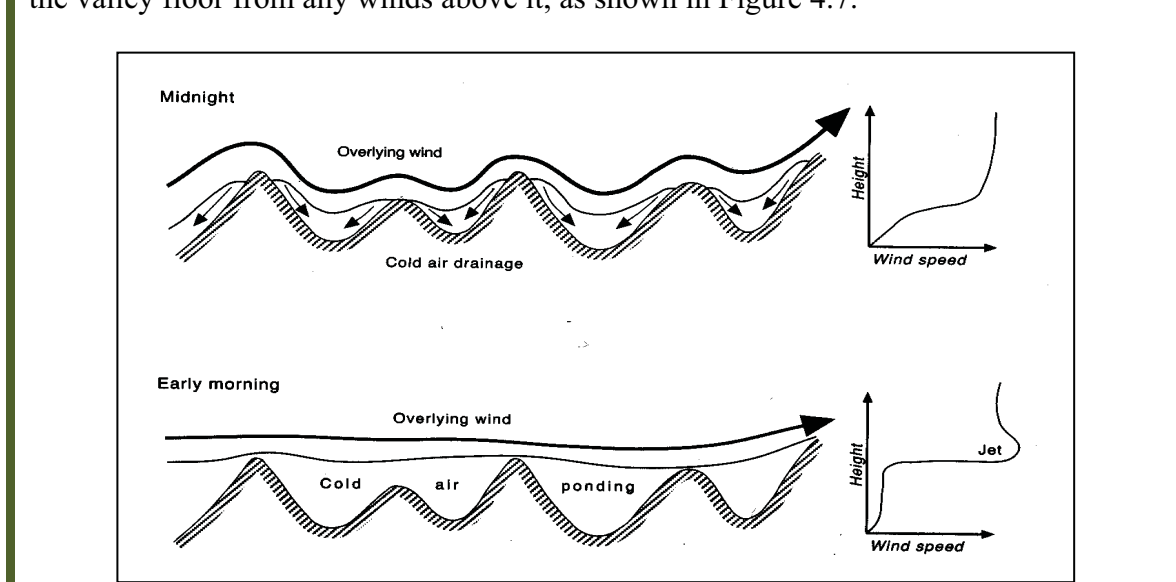

Figure 4.7 The effect of cold air drainage on synoptic airflow over complex terrain. Source: Sturman and Tapper, 2006, p 317

4.2 Arrowtown

Continuous, daily monitoring began in Arrowtown in July 2006. Results are shown in Figure 4.8. Here, as in Alexandra, the colder months experience elevated PM₁₀ levels while summer months have relatively good air quality.

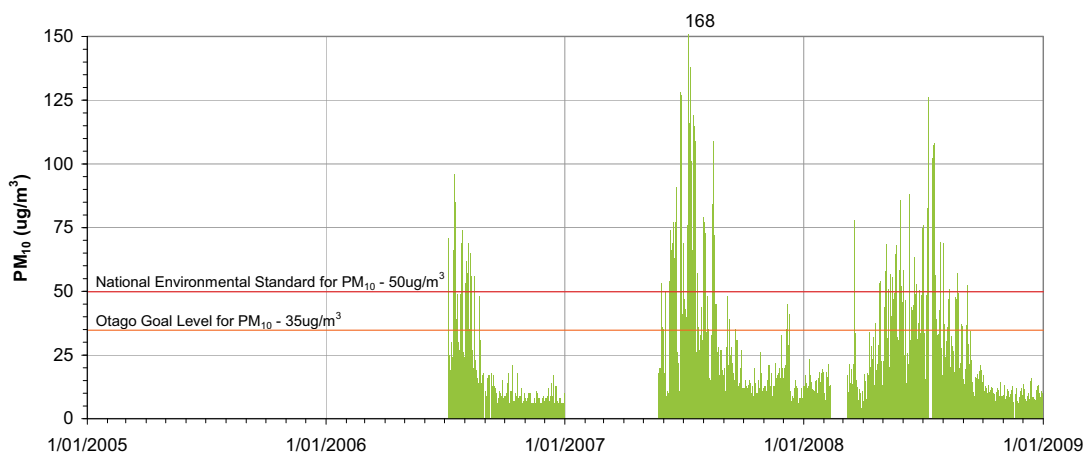

Figure 4.8 Daily PM₁₀ values for Arrowtown from July 2006 to December 2008

Table 4.2 summarises the results. The unit did not run from January 2007-May 2007 so no annual average is available for 2007. Of the four Central Otago towns that exhibit high pollution days during winter (Alexandra, Arrowtown, Clyde, and Cromwell), Arrowtown has recorded the highest one-day value (168µg/m³). This occurred during July 2007 during a particularly long spell of high pressure over the area which resulted in a series of strong temperature inversions.

Table 4.2 Summary statistics for Arrowtown (PM₁₀ in µg/m³)

Year	Annual average	Maximum and second highest daily values	Number of high pollution days (>50µg/m ³)	May-Aug Average
2006	-	96 / 85	18	38
2007	-	168 / 138	39	52
2008	25	126 / 109	38	43
Average	-	130/ 111	32	45

Since the monitor was installed during July 2006 a comparison to other winters is limited. However, the winters of 2007 and 2008 are similar in both magnitude and frequency of high pollution days.

Monthly statistics are shown in Figure 4.9. As with Alexandra, May to July experienced the highest daily levels of PM₁₀, with the averages just below 50µg/m³.

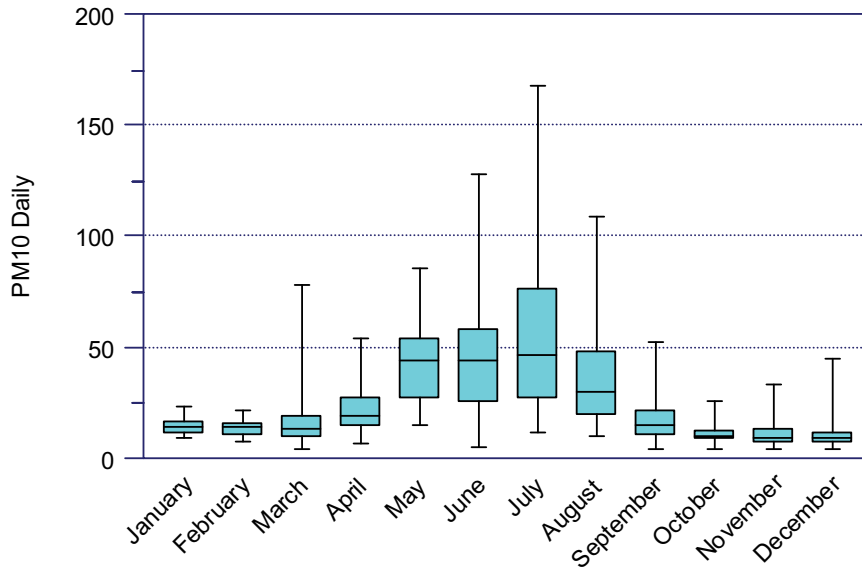

Figure 4.9 Box plots of monthly summary values for Arrowtown (July 2006-Dec 2008)

Arrowtown is situated at the base of the hill along the Arrow River. Due to the low sun angle during winter, the floor of the valley does not receive direct sunlight until late in the morning. Because it takes so long to warm the ground, any overnight temperature inversion can last well into late morning. It is suspected that once the inversion begins to break up and particulates start to move they are transported through the lower reaches of the atmosphere, causing the peak seen around 9 to 10am. This peak is after any expected fire start-up in the early morning. Once the inversion is broken, particulates will clear. The lowest PM₁₀ levels are typically noted during afternoon (Figure 4.10).

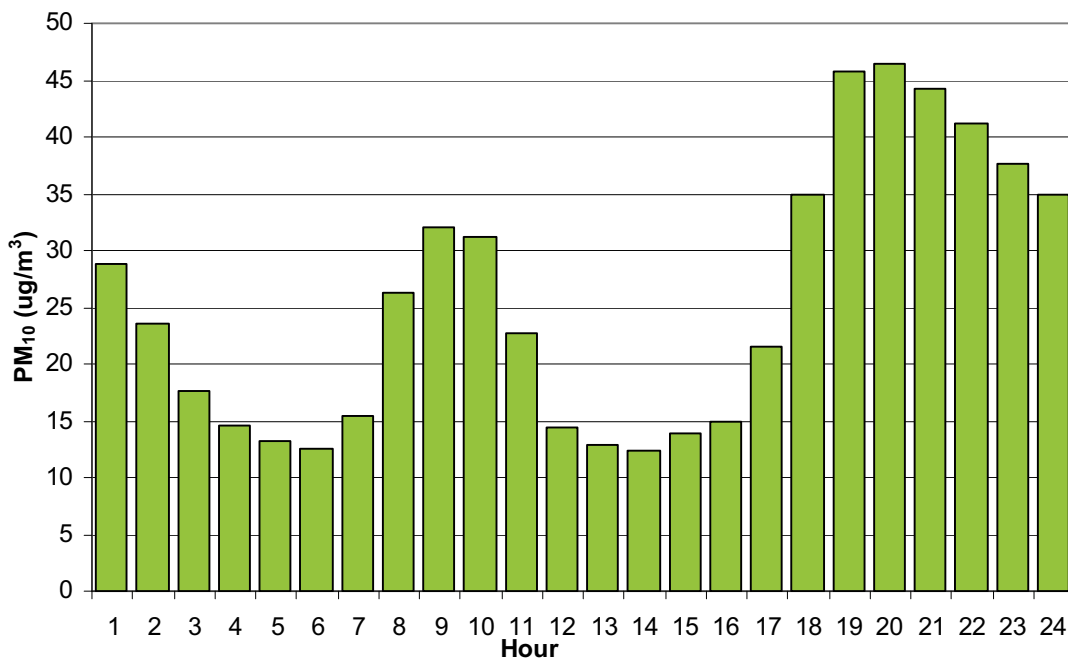

Figure 4.10 Diurnal trends in PM₁₀ at Arrowtown

4.3 Clyde

A continuous air quality monitor was installed during April 2008. Prior to this, no data had been collected in Clyde. This first season of monitoring showed that Clyde experiences numerous high pollution days (Figure 4.11).

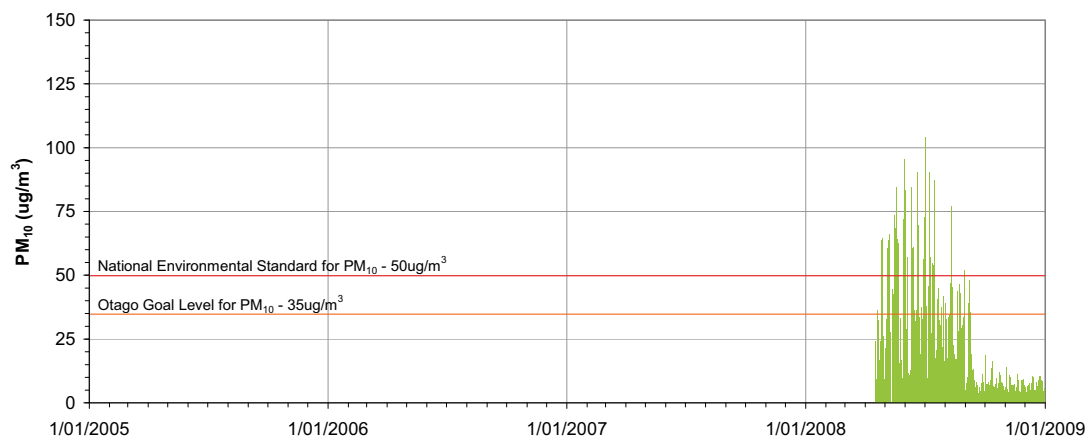

Figure 4.11 Daily PM₁₀ values for Clyde in 2008

A total of 39 days had daily averages higher than the AQNES, the first of which occurred in late April. The highest day recorded a PM₁₀ value of 104 $\mu\text{g}/\text{m}^3$ on 2 July 2008. The winter daily average of 40 $\mu\text{g}/\text{m}^3$ is well over the Otago goal level. Summary results of the monitoring are given in Table 4.3.

Table 4.3 Summary statistics for Clyde (PM₁₀ in $\mu\text{g}/\text{m}^3$)

Year	Annual average	Maximum and second highest daily values	Number of high pollution days (>50 $\mu\text{g}/\text{m}^3$)	May-Aug average
2008	-	104 / 96	39	40
Average	-	104 / 96	-	40

The monthly PM₁₀ summaries are shown in Figure 4.12. Typical of other Central Otago towns, May to August showed elevated PM₁₀ levels. May values appeared at least as significant as those recorded during the other winter months. Continued monitoring will indicate if this is a typical pattern.

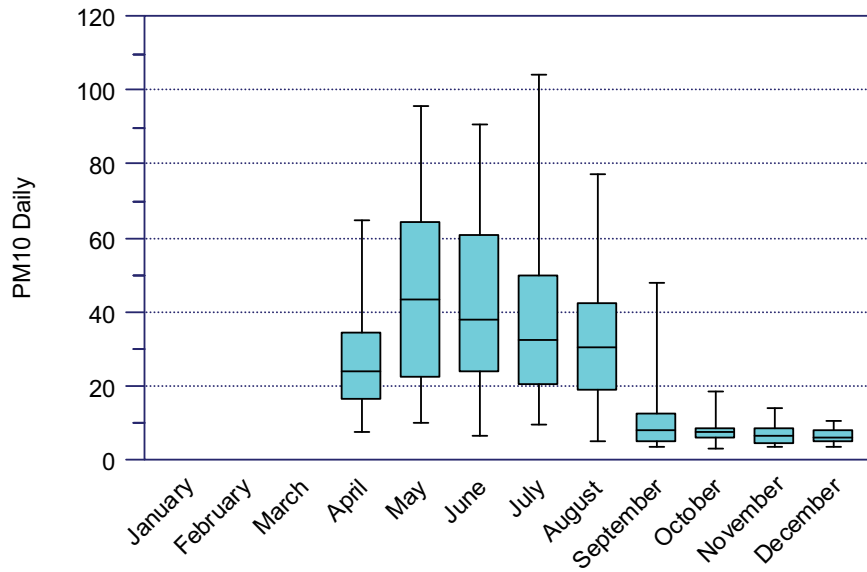

Figure 4.12 Box plots of monthly summary values for Clyde (Apr 2008 - December 2008)

Clyde did exhibit very similar patterns to Alexandra in terms of daily PM₁₀ trends (Figure 4.13). During a typical day, values start to increase during early evening, presumably as fires are lit and emissions begin to accumulate near the surface. Values peak around midnight and then slowly decrease through the early morning hours. Once the temperature inversion starts to break up, particulates are mixed through the lower part of the atmosphere before they disperse towards midday.

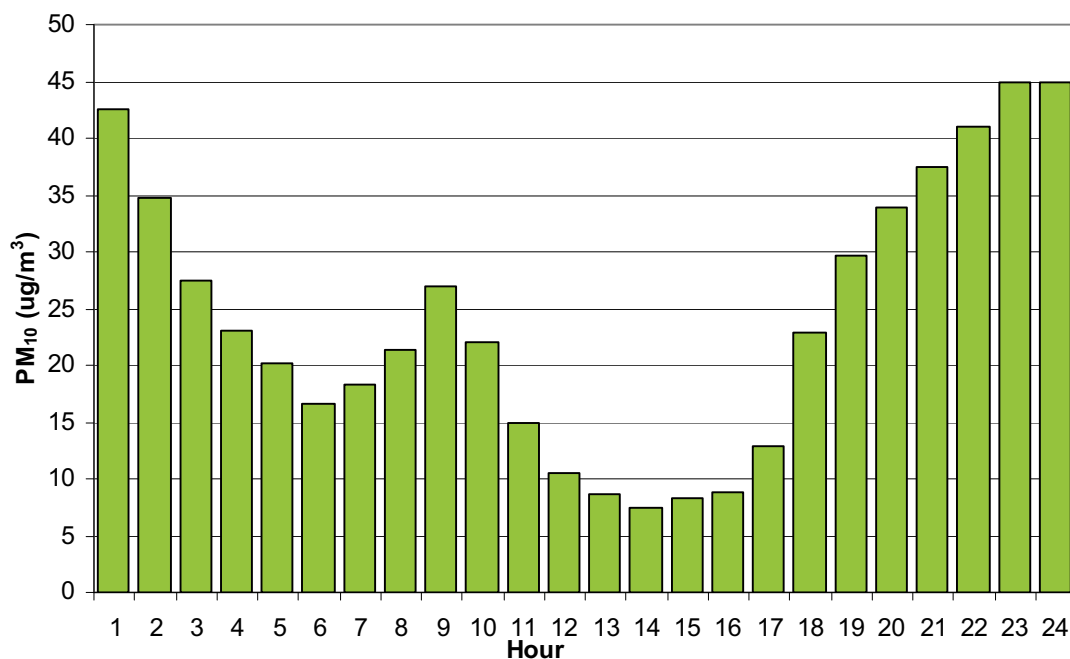

Figure 4.13 Diurnal trends in PM₁₀ at Clyde

4.4 Cromwell

Air quality monitoring in Cromwell began in January of 2008. Results are shown in Figure 4.14. Indications from this one year of monitoring are that Cromwell experiences high pollution days during winter and that patterns of daily and monthly trends are similar to other Central Otago towns where there is heavy reliance on solid fuel burners for heating.

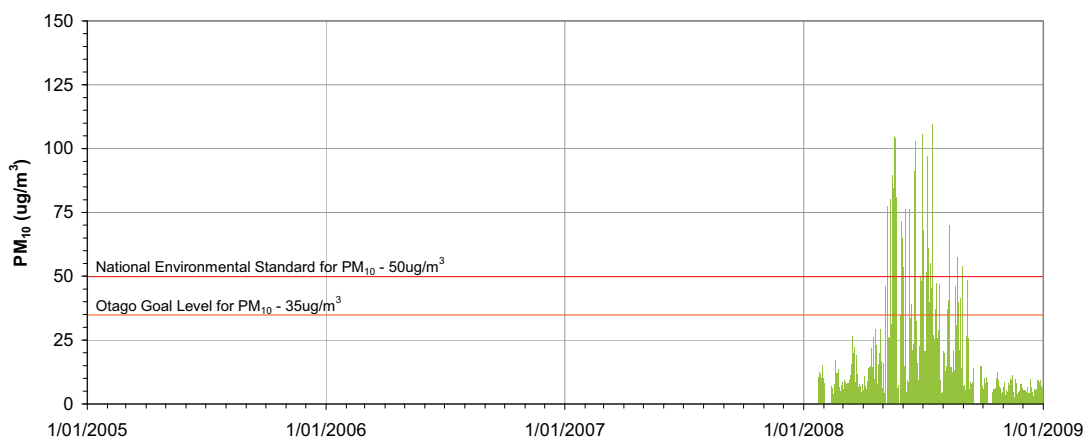

Figure 4.14 Daily PM₁₀ values for Cromwell from January 2008 to December 2008

The annual average for Cromwell is just at the MfE guideline value of 20 $\mu\text{g}/\text{m}^3$. However, there were over 32 high pollution days, with a maximum of 109 $\mu\text{g}/\text{m}^3$ on 15 July 2008. The average daily value over the months from May to August is 37 $\mu\text{g}/\text{m}^3$, which is over the Otago goal level. These summary statistics are shown in Table 4.4.

Table 4.4 Summary statistics for Cromwell (PM₁₀ in $\mu\text{g}/\text{m}^3$)

Year	Annual average	Maximum and second highest daily values	Number of high pollution days (>50 $\mu\text{g}/\text{m}^3$)	May-Aug average
2008	20	109 / 105	32	37
Average	20	109 / 105	-	37

Plots of the values by month (Figure 4.15) show that high values for May, June, and July were all well over 100 $\mu\text{g}/\text{m}^3$. As with Clyde, continued monitoring will indicate whether these are typical pollution trends in Cromwell.

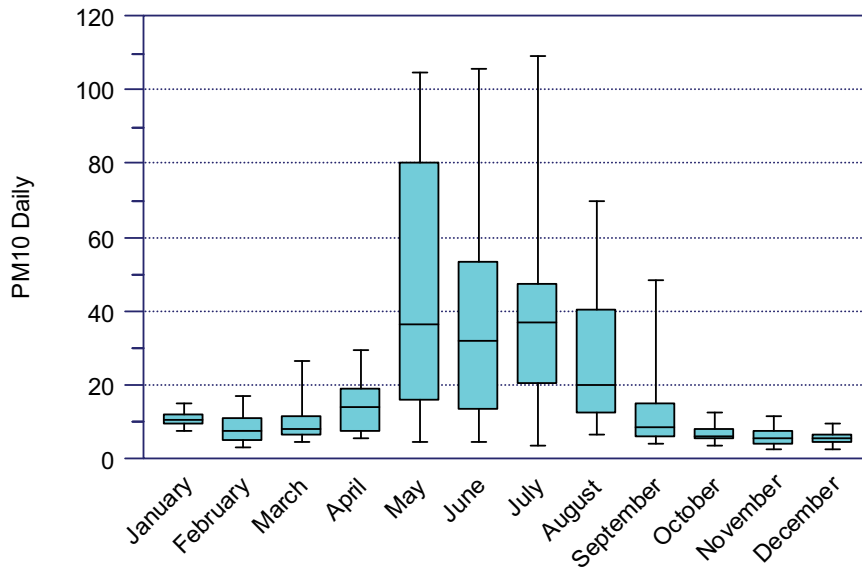

Figure 4.15 Box plots of monthly summary values for Cromwell (January 2008 – December 2008)

The daily pattern of PM₁₀ levels is shown in Figure 4.16. Similar to Alexandra, Arrowtown and Clyde, levels rise during early evening as increased emissions accumulate near the surface.

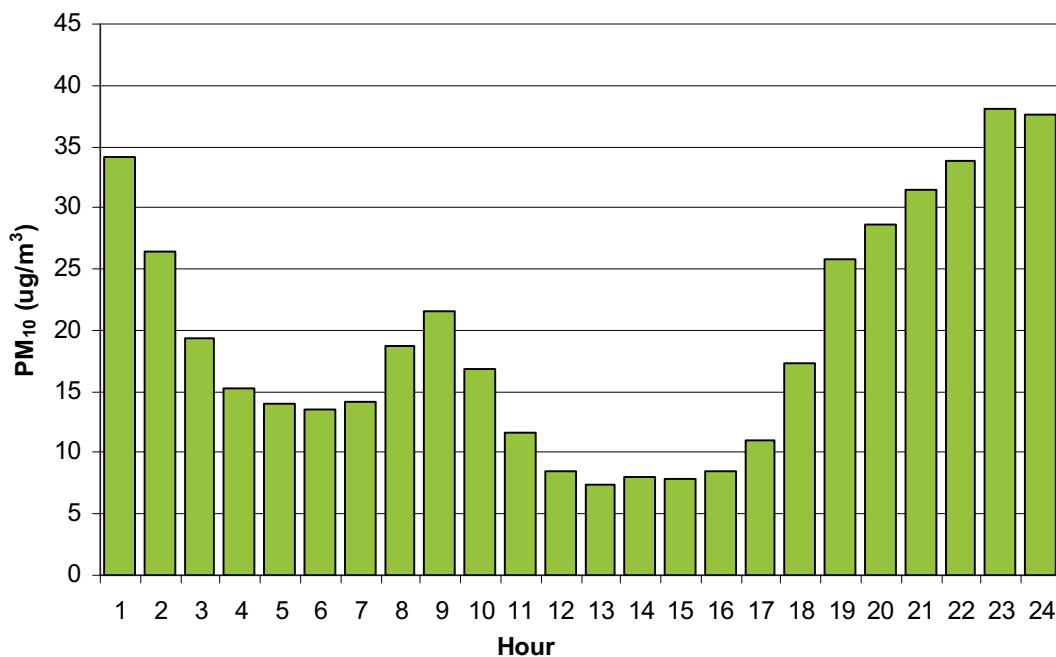

Figure 4.16 Diurnal trends in PM₁₀ at Cromwell

4.5 Central Dunedin

Continuous monitoring of PM₁₀ in the Central Dunedin site at Albany Street commenced in 2006. Since then, 17 exceedances of the NES have been recorded as shown in Figure 4.17.

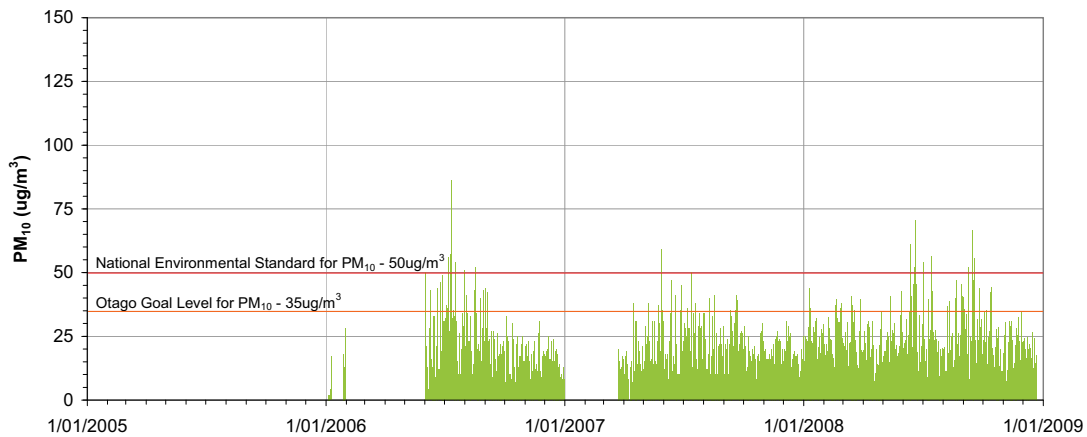

Figure 4.17 Daily PM₁₀ values for Central Dunedin from 2006 to 2008

The pattern of PM₁₀ in Central Dunedin is very different to any other site in Otago. While exceedances of the NES are generally only experienced in the winter time, the summer months exhibit a similar level of PM₁₀ as shown by the box plots and the time series (Figures 4.17 and 4.18). Average winter PM₁₀ levels are only slightly higher than those during summer, just the high pollution days seem to be absent during summer. This pattern is probably indicating that sources of PM₁₀ are coming from multiple sources and not just domestic solid fuel heating.

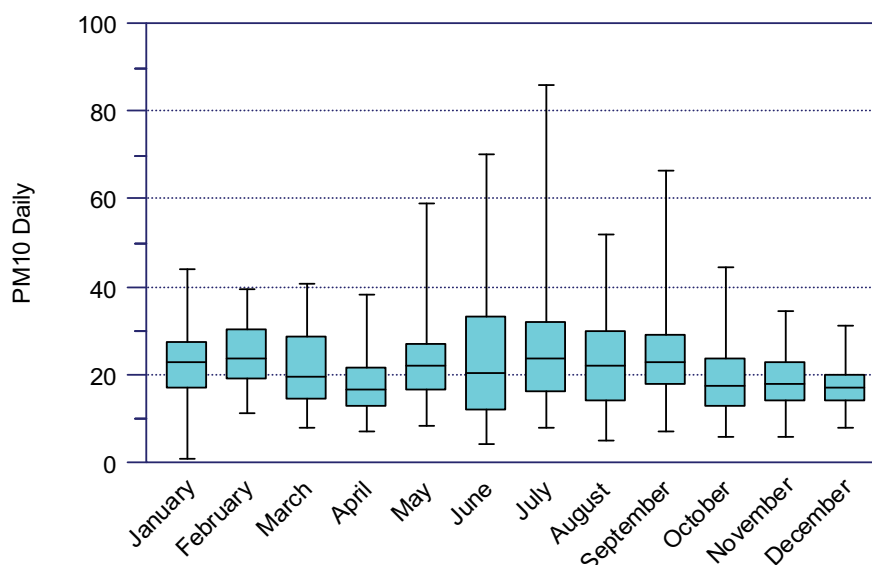

Figure 4.18 Box plots of monthly summary values for Central Dunedin (2006 - 2008)

In addition to this, the diurnal pattern of PM₁₀ is very different to other centres (Figure 4.19). Here it is highest in the daytime from 1000 h to 1800 h and lowest in the early morning. This indicates the site is likely to be influenced mainly from industrial, commercial and possibly transport emissions, rather than domestic heating. The summer and winter diurnal patterns show some differences, notably higher PM₁₀ in the winter months in the evening period (likely due to increased solid fuel heating in domestic and commercial premises and the formation of temperature inversions).

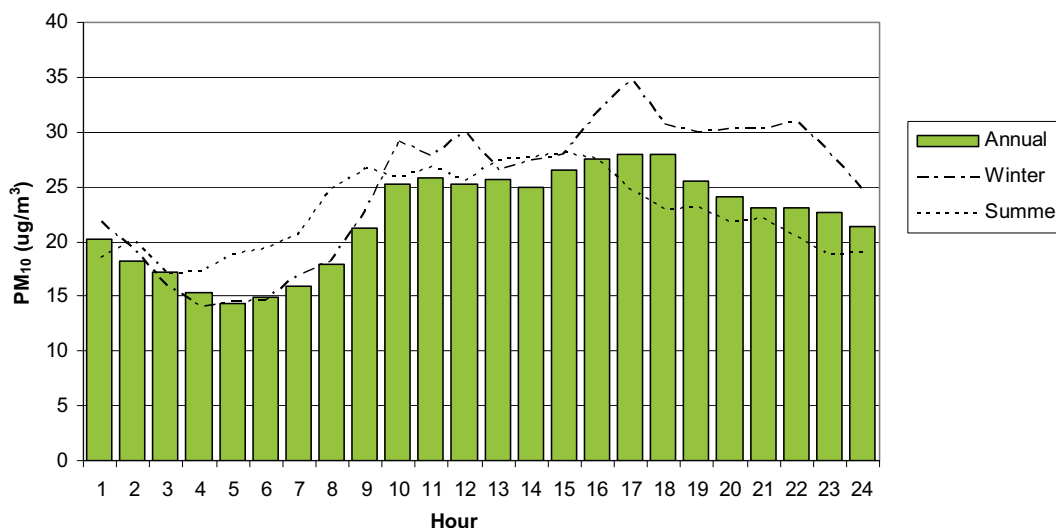

Figure 4.19 Average hourly concentrations of PM₁₀ in Central Dunedin depicted for: All data, Winter months (May-August), and Summer months (December – March)

Table 4.5 shows a summary of the annual and winter statistics from each year. While only a moderate number of exceedances are experienced each year the annual average has been higher than the MfE guideline value of 20µg/m³ in most years.

Table 4.5 Summary statistics for Central Dunedin (PM₁₀ in µg/m³)

Year	Annual average	Maximum and second highest daily values	Number of high pollution days (>50µg/m ³)	May-Aug average
2005	21*	52* / 45*	1*	27*
2006	25*	86 / 57	6	26
2007	20	59 / 50	2	21
2008	24	70 / 66	9	25
Average	22	67 / 55	6	25

* from intermittent monitoring

Trends in Central Dunedin’s air quality

A brief examination of the trends in PM₁₀ air quality in Central Dunedin from 1997 to 2008 shows no clear pattern (Figure 4-20). The annual average and September – April average concentrations show steady levels of PM₁₀ around 20-25µg/m³. The average winter time level does show a slight downward trend. Due to differences in the monitoring techniques, it is unclear if this trend is significant or not. In addition,

differences in weather patterns from year to year can hide whether changes in average PM_{10} are caused by changes in the level of emissions of PM_{10} .

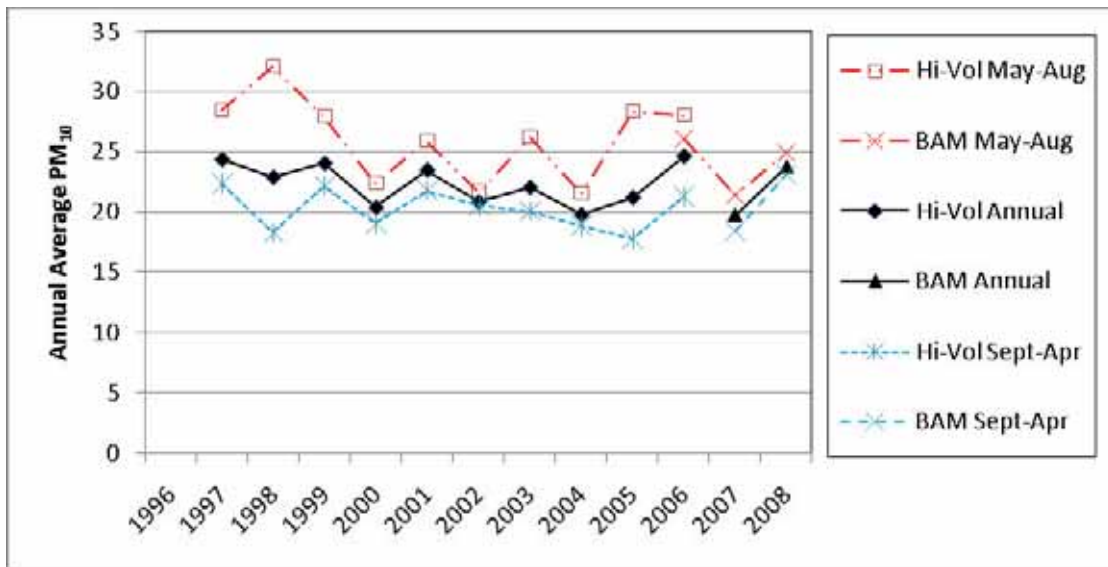

Figure 4.20 Trends in PM_{10} air quality at Central Dunedin from 1997 to 2008

4.6 North Dunedin

Intermittent readings of PM_{10} were made in North Dunedin up until the end of winter 2007. These show a seasonal pattern of moderate values in the winter period and lower values during the summer months (Figures 4.21 and 4.22).

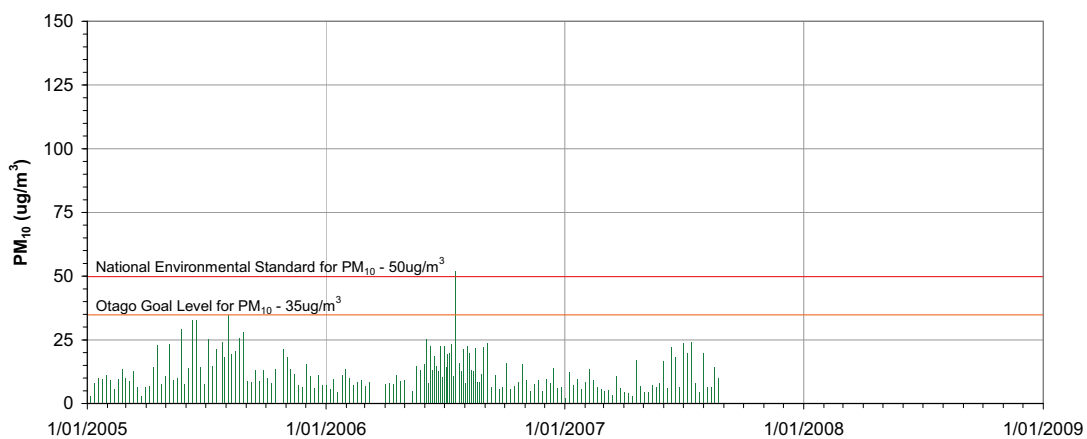

Figure 4.21 Recorded daily average PM_{10} levels in North Dunedin from 2005 to 2007

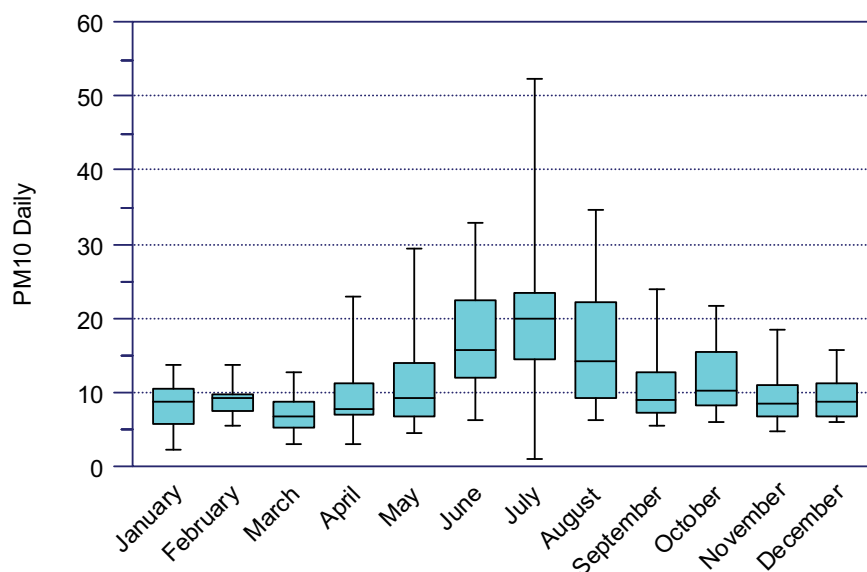

Figure 4.22 Box plots of monthly summary values for North Dunedin

This is in contrast to the Central Dunedin site but is similar to the provincial towns of Otago, indicating the likely source is domestic heating and solid fuel burners in commercial premises. One exceedance of the NES was recorded which, given the intermittent monitoring schedule, suggests an exceedance would occur on average once a year (Table 4.6). Other sites with similar winter average levels have few to no exceedances per year.

Table 4.6 Summary statistics for North Dunedin (2005-2007)

Year	Annual average	Maximum daily value	Number of high pollution days (>50µg/m ³)	May-Aug Average
2005	14*	35*	0*	20*
2006	13*	52*	1*	16*
2007	-	24*	0*	12*
Average	13*	37*	1**	16*

* from intermittent monitoring

** corrected for intermittent monitoring schedule

Trends in North Dunedin’s air quality

The level of PM₁₀ at the North Dunedin monitor on North Road showed a steady decrease in annual average PM₁₀ (Figure 4.23).

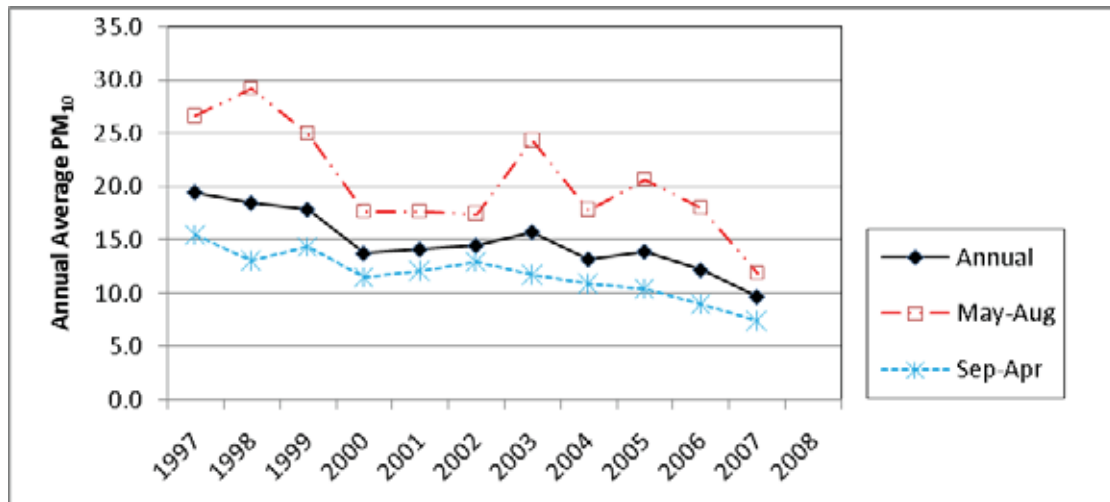

Figure 4.23 Trend in PM₁₀ levels in North Dunedin from 1997 to 2007

Reasons for this improvement in air quality could be changes in heating patterns, resulting in decreased emissions in Dunedin. For example there has been increased use of gas and heat pumps for heating and a decrease in wood and coal use (Figure 4.24). In addition, the increased level of insulation and decreased emissions from newly installed wood burners will have decreased emissions in the area. Also, two consented discharges of PM₁₀ from a fur processing plant and a laundry process, that were in close proximity to the monitor, have ceased since monitoring began. One ceased sometime before June 1999 and the other around June 2006.

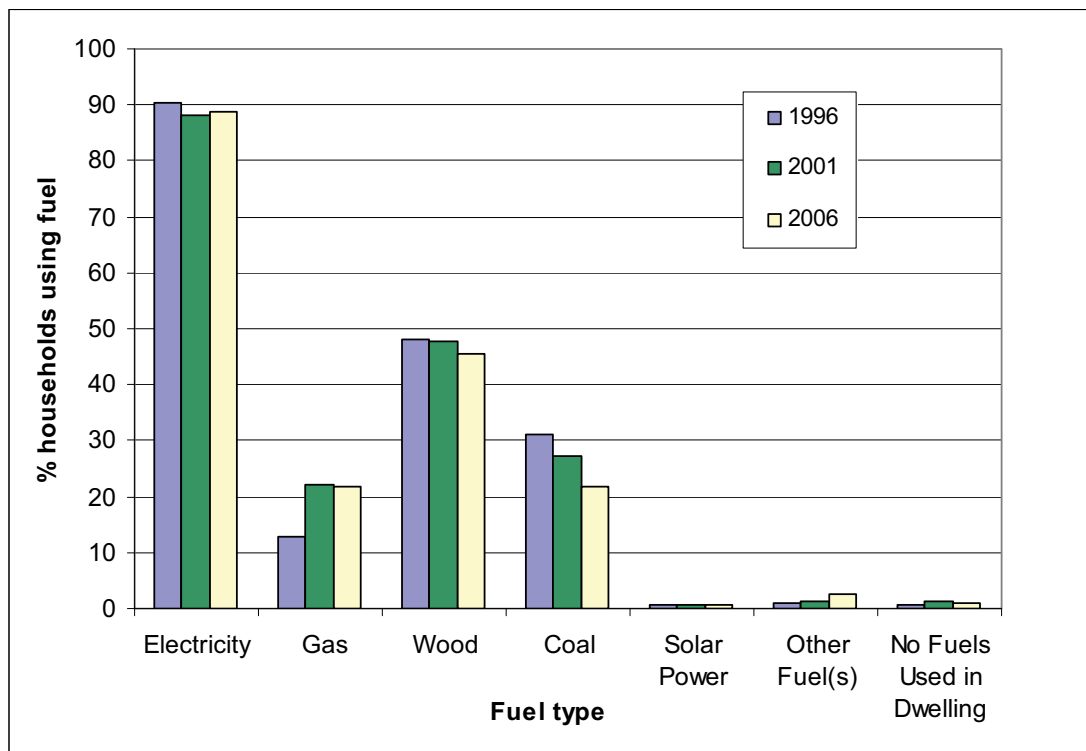

Figure 4.24 Trends in the use of fuel type from 1996 to 2006 (Census of Population and Dwellings, Statistics NZ)

4.7 South Dunedin

Intermittent monitoring of PM₁₀ in South Dunedin began in May 2007. Results are shown in Figure 4.25. The daily average PM₁₀ levels show that on most days PM₁₀ is at relatively low levels between 10 and 30 µg/m³. Higher levels are experienced during the winter months, with two exceedances of the NES being recorded since monitoring started, one each winter. Because of the intermittent monitoring schedule, it is likely that further exceedances would have been recorded. During 2008, five out of nine exceedances at the Central Dunedin site occurred on days the South Dunedin site was not sampled.

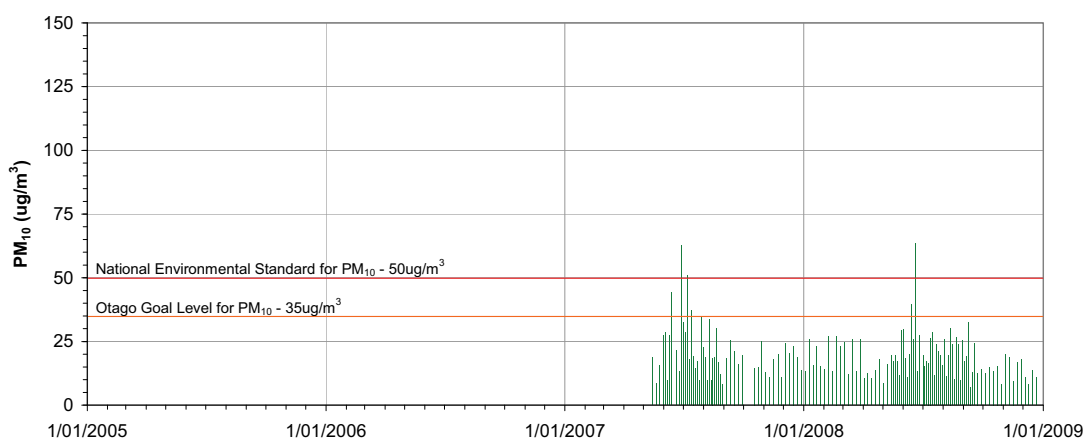

Figure 4.25 Recorded daily average PM₁₀ levels in South Dunedin from 2007 to 2008

The box plots in Figure 4.26 show variable PM₁₀ levels, with April appearing to be the lowest and June the highest. However, the months of December to March also show slightly elevated levels of PM₁₀ following the trend of Central Dunedin. Further years of monitoring will give a better idea of the pattern of PM₁₀ in South Dunedin. Interestingly, very few days record PM₁₀ below 10 µg/m³, perhaps indicating that there is a higher background level of PM₁₀ in South Dunedin than in either North or Central Dunedin throughout the year.

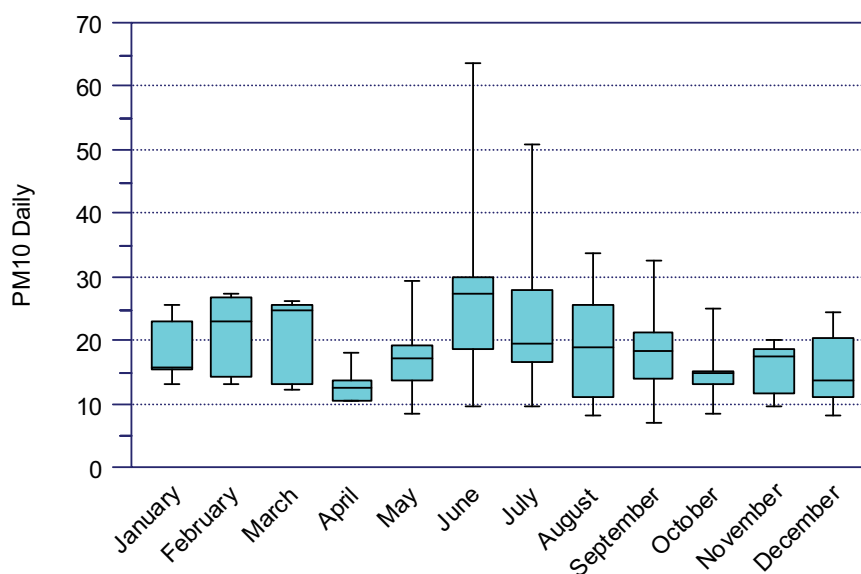

Figure 4.26 Box plots of monthly summary values for South Dunedin (2007 - 2008)

Summary statistics for the South Dunedin site are shown in Table 4.7.

Table 4.7 Summary statistics for South Dunedin

Year	Annual average	Maximum and second highest daily values	Number of high pollution days ($>50\mu\text{g}/\text{m}^3$)	May-Aug average
2007	-	63 / 51*	2*	23*
2008	19*	64 / 40*	1*	21*
Average	19*	64 / 46*	5**	22*

* values from intermittent monitoring

** corrected for 1 day in 3 monitoring schedule

The diurnal pattern of PM_{10} was monitored in June/July 2007 by a student from the Department of Geography, University of Otago (Osman, 2007). This showed the pattern in South Dunedin was similar to that in the provincial towns of Otago rather than that of Central Dunedin, with the highest values experienced in the evening period, and a slightly lower peak around 8-10 am in the morning (Figure 4.27). The evening peak indicates that domestic emissions are likely to be a significant contributor to PM_{10} in South Dunedin.

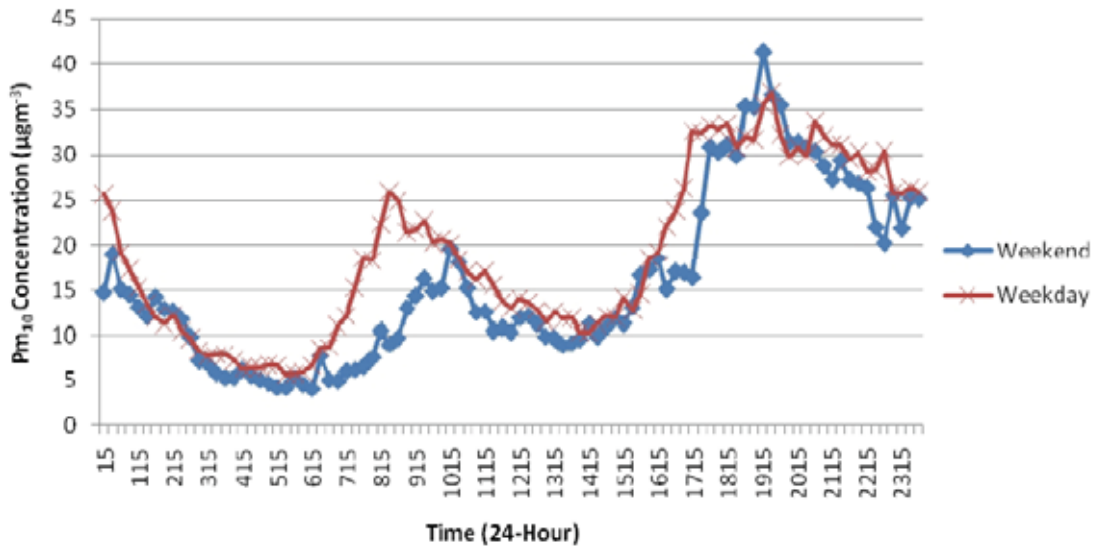

Figure 4.27 The diurnal pattern of PM₁₀ measured in South Dunedin by the Geography Department of The University of Otago

4.8 Lawrence

An intermittent monitor was installed in Lawrence in mid-August 2008. During 2008, a total of 25 days were sampled. The highest value was 31µg/m³, recorded on 21 August which means that, so far, all days fall within the Otago goal level of 35µg/m³. In order to get a more complete picture of the air quality issues in Lawrence, monitoring is scheduled to continue.

All of the sampled days are shown in Figure 4.28.

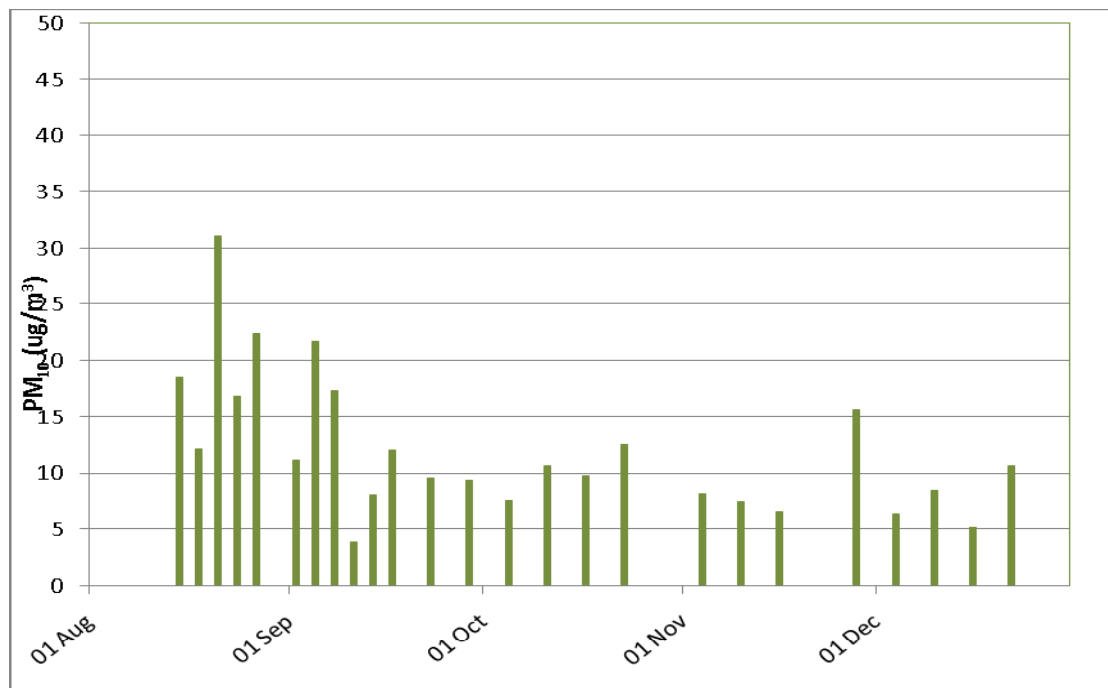

Figure 4.28 Daily recorded PM₁₀ levels in Lawrence during 2008

4.9 Milton

Continuous monitoring of PM₁₀ started in Milton in April 2008. Since then, 46 high pollution days have been recorded, the second highest number at any site bar that in Alexandra during 2008 (Figure 4.29).

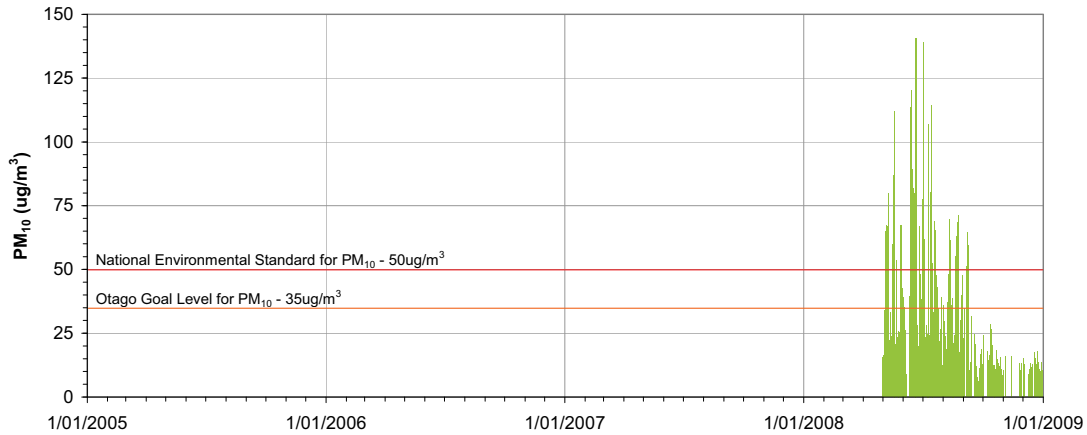

Figure 4.29 Daily PM₁₀ values for Milton during 2008

The average level for winter was 47µg/m³, again second only to Alexandra. Of the days monitored so far, 35% are above the Otago goal level and the highest daily value was 141µg/m³ which is almost three times the NES (Table 4.8). It is clear Milton has similarly high PM₁₀ levels as the towns in Air Zone 1.

Table 4.8 Summary statistics for Milton (PM₁₀ in µg/m³)

Year	Annual average	Maximum and second highest daily values	Number of high pollution days (>50µg/m ³)	May-Aug average
2008	-	141 / 140	46	47
Average	-	141 / 140	-	47

The reasons for the town's high PM₁₀ are relatively clear. There are high emissions of PM₁₀ from domestic heating due to the high use of solid-fuel burners, in particular, multi-fuel burners burning coal as shown by Figure 4.30. As well, there is a significant contribution of PM₁₀ from industry within the airshed. On an average winter day, PM₁₀ emissions from domestic heating are 309kg, less than in Alexandra (380kg). However, in Milton, the emissions come from an area just half the physical size of Alexandra. There are also likely to be frequent temperature inversions, exacerbated by the location of the town in the bottom of a shallow river valley. These temperature inversions have the effect of trapping the emissions close to the surface.

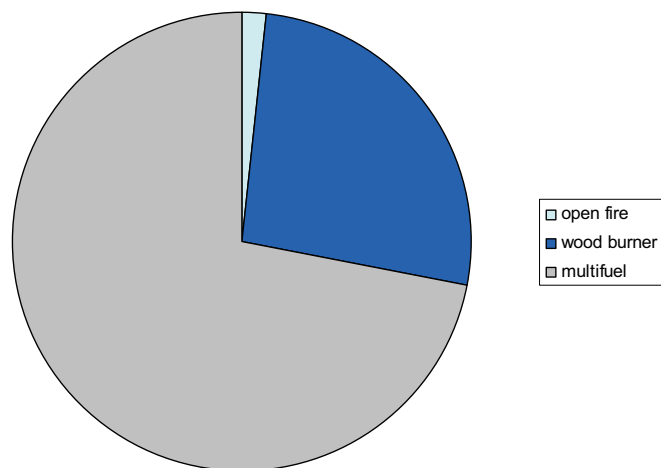

Figure 4.30 Contribution to PM₁₀ emissions from domestic heating appliances in Milton

Diurnal plots of PM₁₀ values indicate the influence typically seen from domestic heating emissions during early evening (Figure 4.31). Values increase sharply through the evening, decrease in the early morning and peak again around 0900 h, as the breakup of the inversion starts to mix the atmosphere.

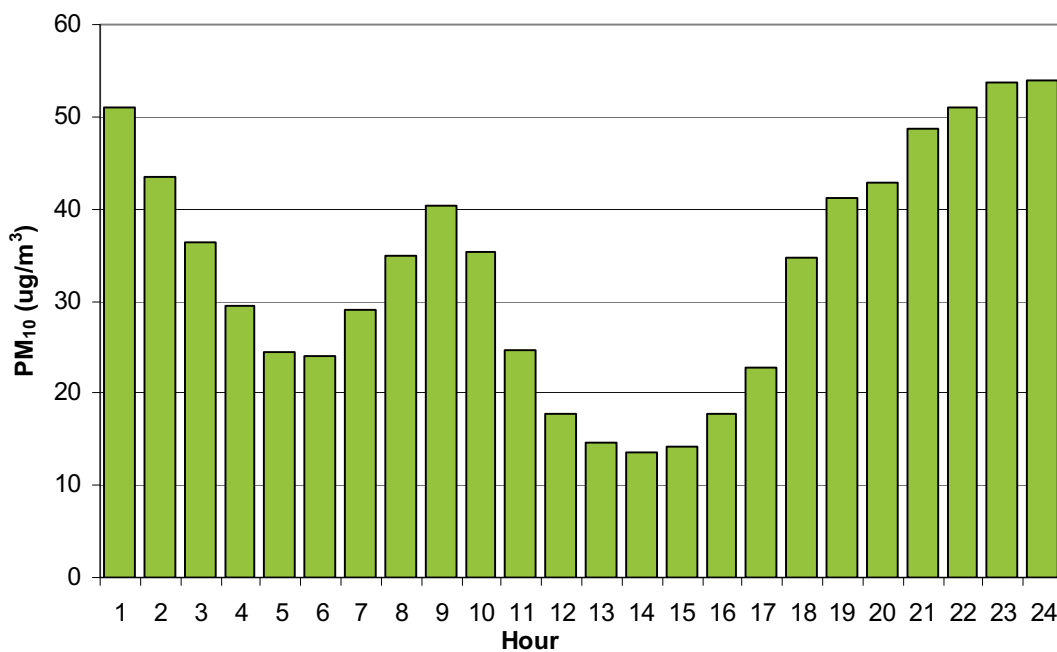

Figure 4.31 Diurnal trends in PM₁₀ at Milton

Box plots of the monthly summaries of data are shown in Figure 4.32. As the monitoring programme continues, the patterns of PM₁₀ in Milton will become clearer.

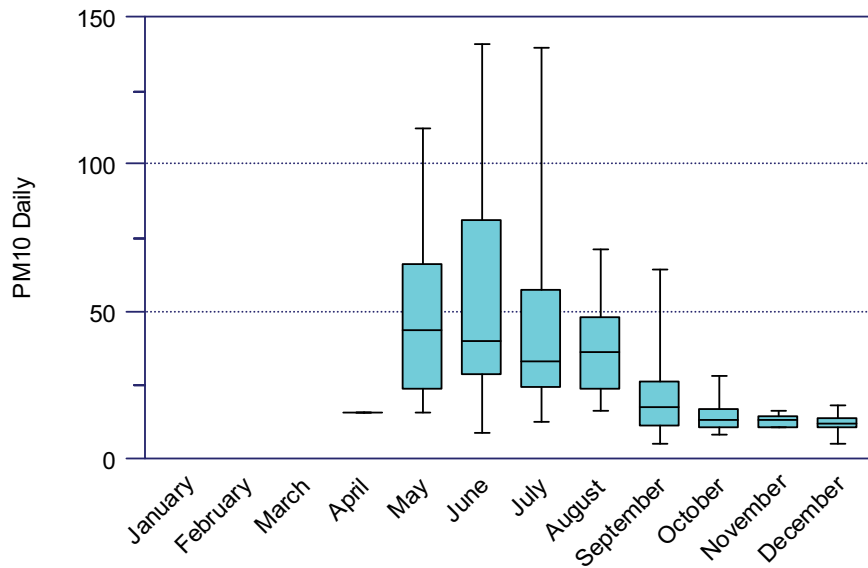

Figure 4.32 Box plots of monthly summary values for Milton in 2008

4.10 Mosgiel

Continuous monitoring of PM₁₀ in Mosgiel has been undertaken since May 2005 (Figure 4.33). On average, eight high pollution days have been recorded each year, and 9% of days are over the Otago goal level (refer Table 4.9).

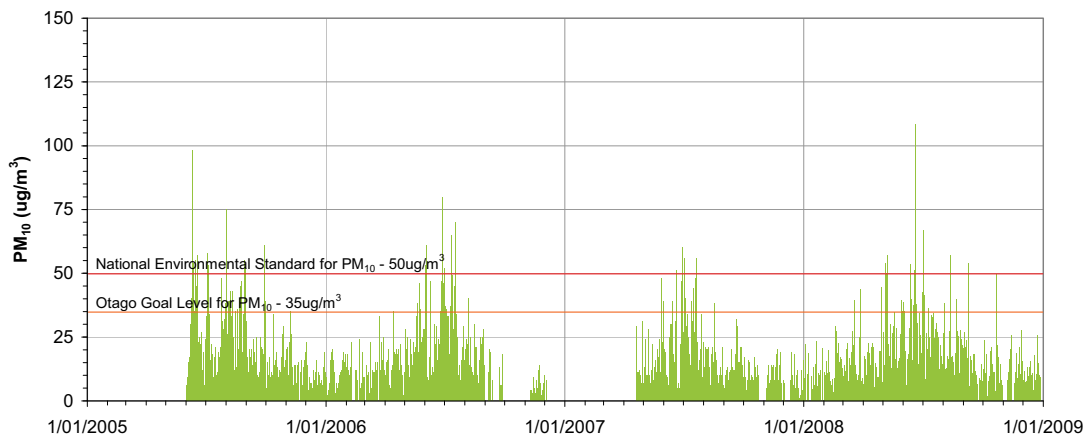

Figure 4.33 Daily PM₁₀ values in Mosgiel from May 2005 to December 2009

The levels of PM₁₀ show a distinct seasonal trend with the winter months of May to August having the highest values and the summer months having the lowest (Figure 4.34). This points to domestic heating emissions as the primary cause of PM₁₀. The emissions inventory conducted in 2005 showed industry contributes around 10% of the PM₁₀ emissions on an average winter's day, with most of this coming from a large wood waste boiler on the northern outskirts of the town.

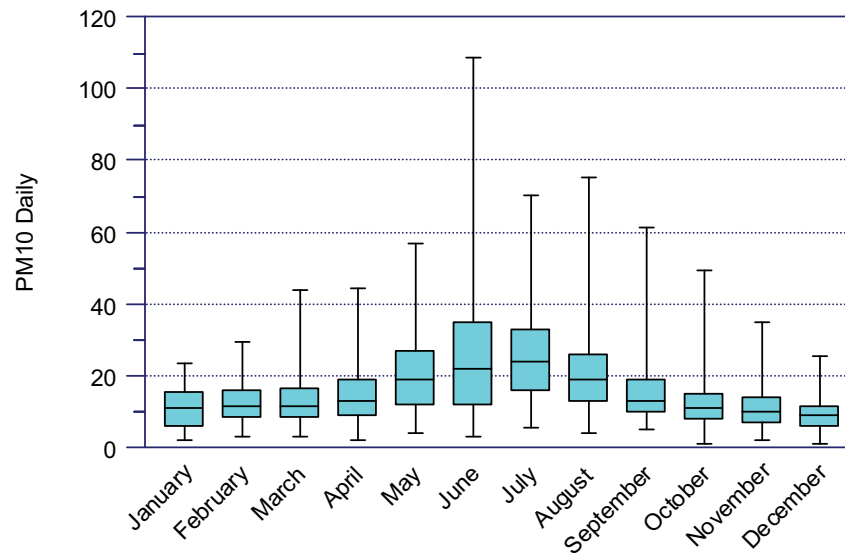

Figure 4.34 Box plots of monthly summary values for Mosgiel (June 2005 – Dec 2008)

As shown in Table 4.9, the annual average has fluctuated close to the national guideline level of $20 \mu\text{g}/\text{m}^3$ for the last four years. Looking at the maximum and second-highest values for each year, 2008 stands out as having a very high maximum. From 2005 to 2007, the maximum was approximately 11% greater than the second highest value; in 2008, it was nearly 40% greater. It would appear to be an outlier.

Table 4.9 Summary statistics for Mosgiel from 2005 to 2008

Year	Annual average	Maximum and second highest daily values	Number of high pollution days (>50µg/m ³)	May-Aug Average
2005	24*	98 / 88	11	28
2006	17	80 / 70	8	24
2007	19*	60 / 56	4	19
2008	18	108 / 77	9	25
Average	19	87 / 73	8	24

* from intermittent monitoring

Trends in Mosgiel's air quality

The air quality monitoring site in Mosgiel is located along Factory Road at the Mosgiel Industrial Estate and, as such, results include emissions from residential and industrial sources. During the course of monitoring, PM₁₀ levels increased from 2001 to a peak in 2004 (Figure 4.35). Since then, they decreased until 2008. Whether these increases and decreases are due to changing emissions or to the natural variability of the weather is unknown.

While annual averages have remained between about 14 to 19µg/m³, winter months' averages have ranged between 20 and 42µg/m³. At this stage, no overall trend can be identified. It will require several more years of data collection to identify a significant change in PM₁₀ at this site.

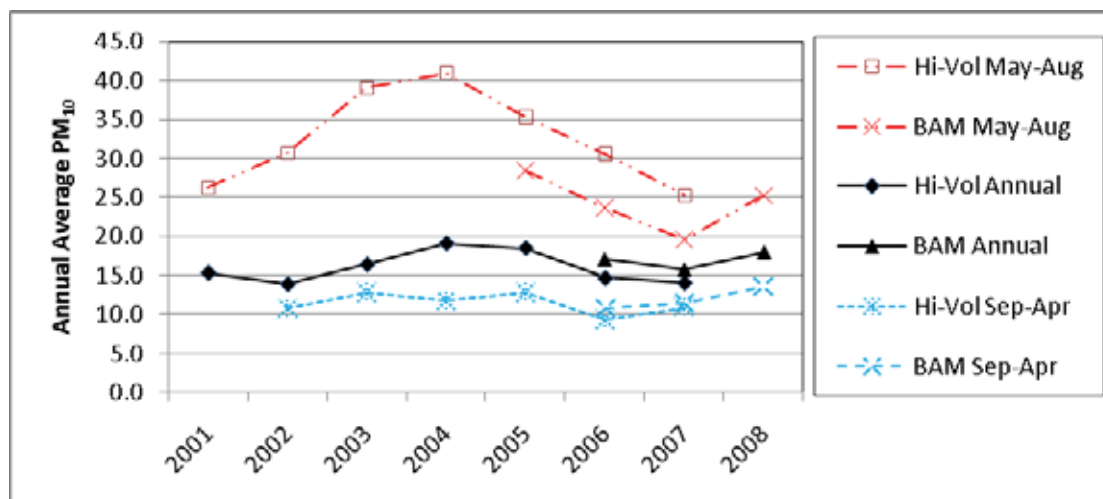

Figure 4.35 Trends in PM₁₀ air quality at Mosgiel from 2001 to 2008

The diurnal pattern of PM₁₀ shows the highest values are recorded in the morning period at 0900 and 1000 h and the lowest values are recorded in the early morning period around 0600 hours (Figure 4.36). Interestingly, the evening period from 1900 to 2400 h shows elevated levels but not to the same extent as experienced in other centres in Otago. The causes of this pattern are not clear, and could include increased emissions in the morning period or the possibility that, through a combination of differences in surrounding land use and meteorology, the monitor experiences lower concentrations than other areas of town during the evening period.

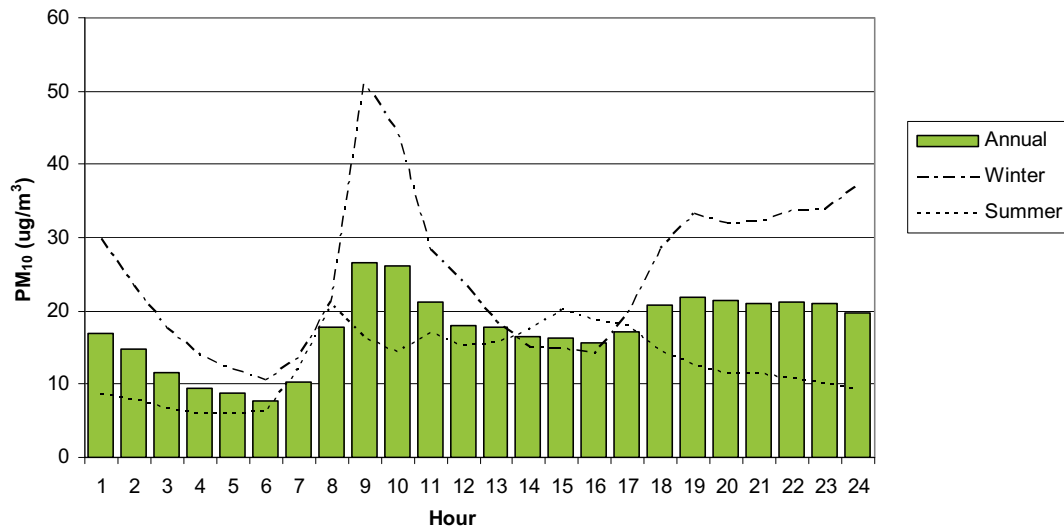

Figure 4.36 Average hourly concentrations of PM₁₀ in Mosgiel depicted for: All data, Winter months (May-August), and Summer months (December - March)

While higher air pollution days occur in the winter months when air temperatures are cold, high pollution days do not correlate well with individual warm and cold days in those months. A study by Mulliner et al. (2007) showed a significant but weak correlation of daily minimum temperature to PM₁₀. This is because the main determinant of PM₁₀ levels, apart from the emissions, is the ability of the atmosphere to disperse the pollution. A cold day may still have the right atmosphere to disperse PM₁₀. Atmospheric stability is most easily measured using the temperature and wind speed differences at two heights in the atmosphere.

Spatial monitoring of PM₁₀ was conducted by both the ORC and the University of Otago's Department of Geography during the winters of 2008 and 2009, in an effort to improve the understanding of the winter air quality problem (see ORC, 2009b for more details). The results show that on some nights PM₁₀ varied by a factor of ten across the built up area of Mosgiel. Each night exhibited different patterns of PM₁₀ but some generalisations can be made. The highest values were found in areas of dense residential land use, which also had residential land use upwind. These areas were in the northern and western sides of town. Moderate values were found on the eastern and central side of town where land use is more mixed (including parks, retirement facilities and schools). Normally, air quality improved outside of the town area; however, the western area on Bush Road often had high values several hundred metres outside town due to the light prevailing winds from the northeast. Figure 4.37 shows a plot of average PM₁₀ concentrations measured by ORC at 23 sites over the study period.

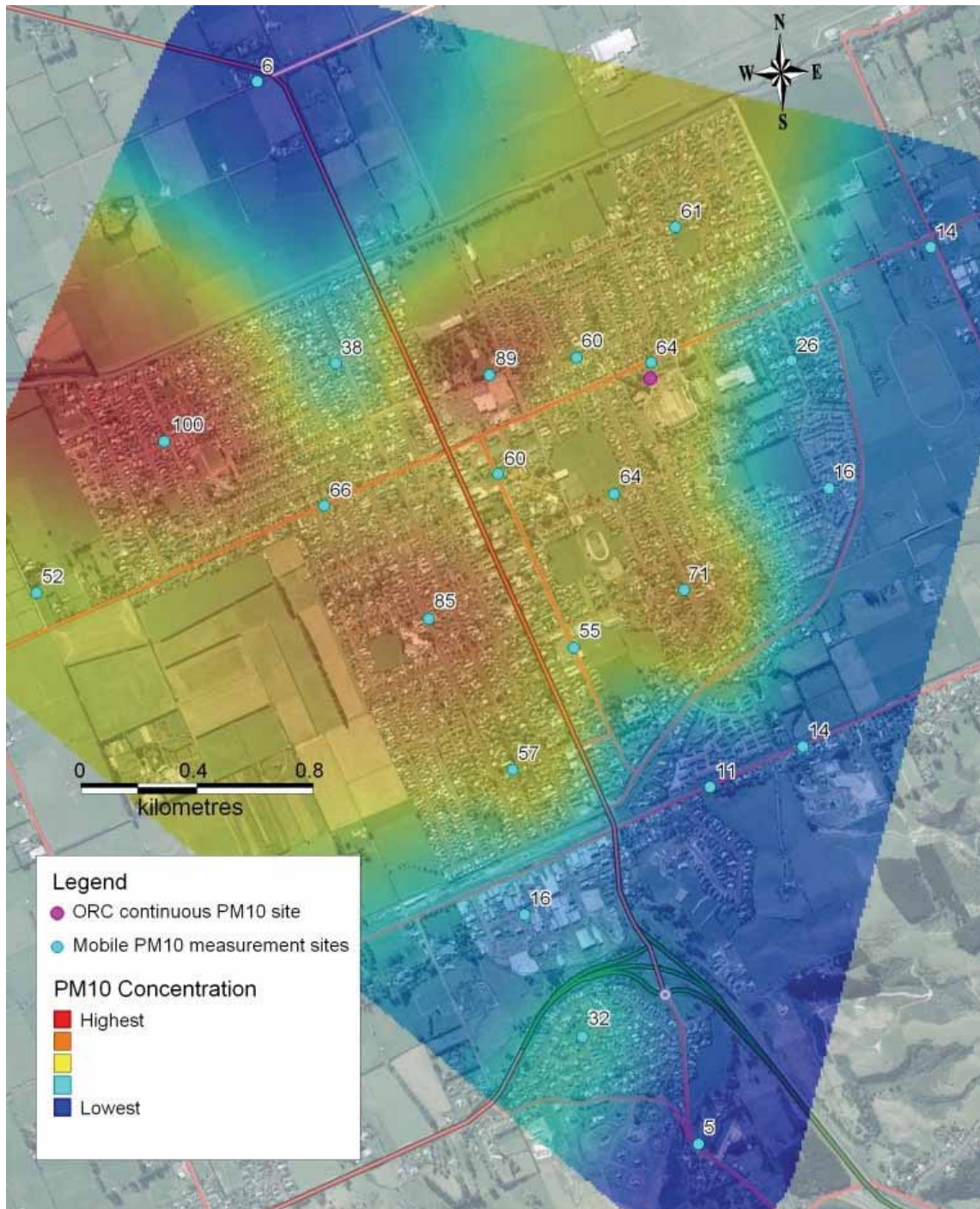

Figure 4.37 Average PM₁₀ ($\mu\text{g}/\text{m}^3$) recorded across Mosgiel during the study period. The blue dots indicate sampling sites used and the pink dot indicates the location of the ORC BAM monitor

4.11 Naseby

PM₁₀ was monitored in Naseby during winter 2007. Results show that the air quality was very good during that time (Figure 4.38 and Table 4.10).

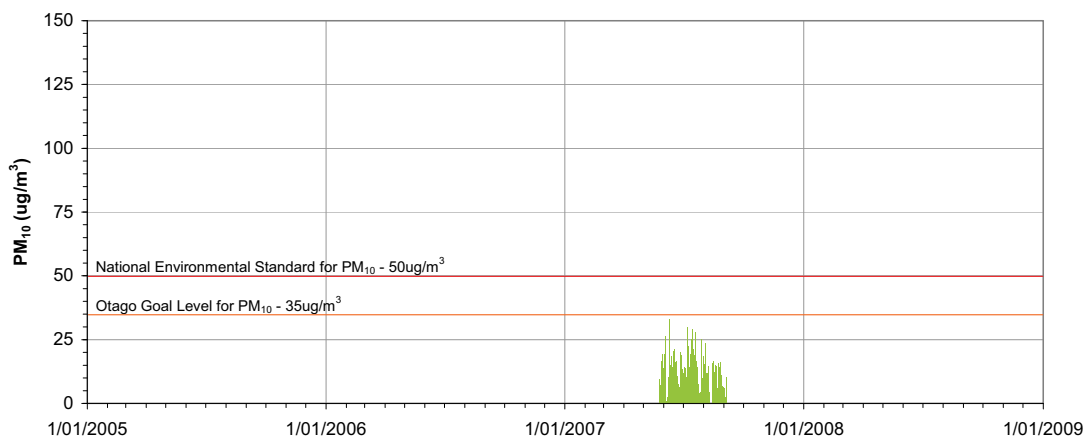

Figure 4.38 Daily PM₁₀ values for Naseby during 2007

Table 4.10 Summary statistics for Naseby (PM₁₀ in $\mu\text{g}/\text{m}^3$)

Year	Annual average	Maximum and second highest daily values	Number of high pollution days ($>50\mu\text{g}/\text{m}^3$)	May-Aug average
2007	-	33 / 30	0	14
Average	-	33 / 30	0	14

Of all sites monitored during that same period, Naseby had the best air quality, with the lowest May-August average of $14\mu\text{g}/\text{m}^3$ and the lowest maximum daily value of all sites ($33\mu\text{g}/\text{m}^3$ on 10 June). Figure 4.39 shows the monthly statistics. The daily values of PM₁₀ recorded during July reflect maximum emissions from domestic heating as this was a period of extremely cold temperatures and strong temperature inversions in Naseby.

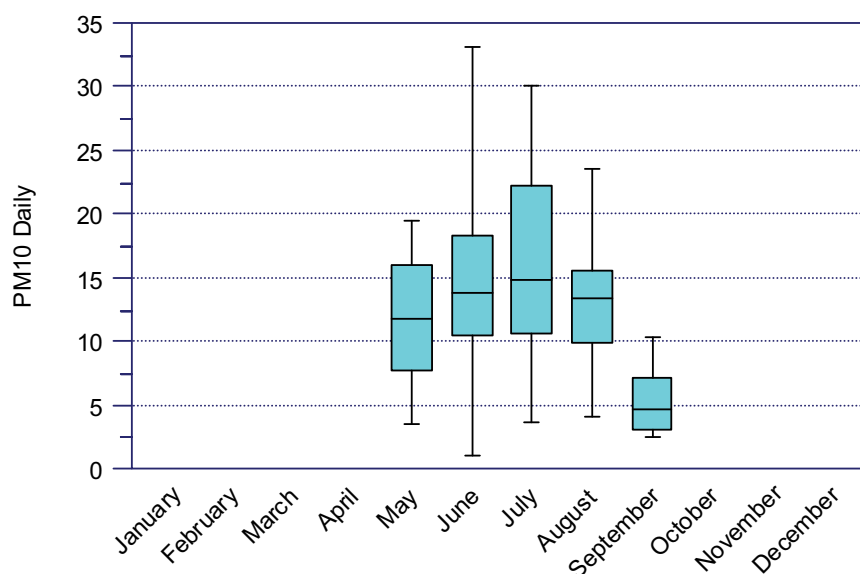

Figure 4.39 Box plots of monthly values for Naseby during 2007

Because the hourly PM_{10} values are available, it is often useful to examine a day in more detail to understand the factors that influence PM_{10} values. On 10 June, for a two-hour period between 1pm and 3pm, hourly PM_{10} values spiked at $179\mu\text{g}/\text{m}^3$ and $134\mu\text{g}/\text{m}^3$. These very high values, occurring during the mid-afternoon, were unlikely to be caused by domestic heating appliances. However, they did contribute to the overall PM_{10} value of $33\mu\text{g}/\text{m}^3$ that day. In this instance, a visit to the site revealed that these high hourly figures were most likely the result of someone cutting nearby firewood with a chainsaw. The diesel emissions from the chainsaw would have been sampled by the air monitor.

Aside from this one site-specific event, it is evident from the hourly figures that the majority of PM_{10} in the air is from domestic heating during cold periods. An average day is shown in Figure 4.40. The values increase during early evening when fires are most likely lit and remain high for several hours.

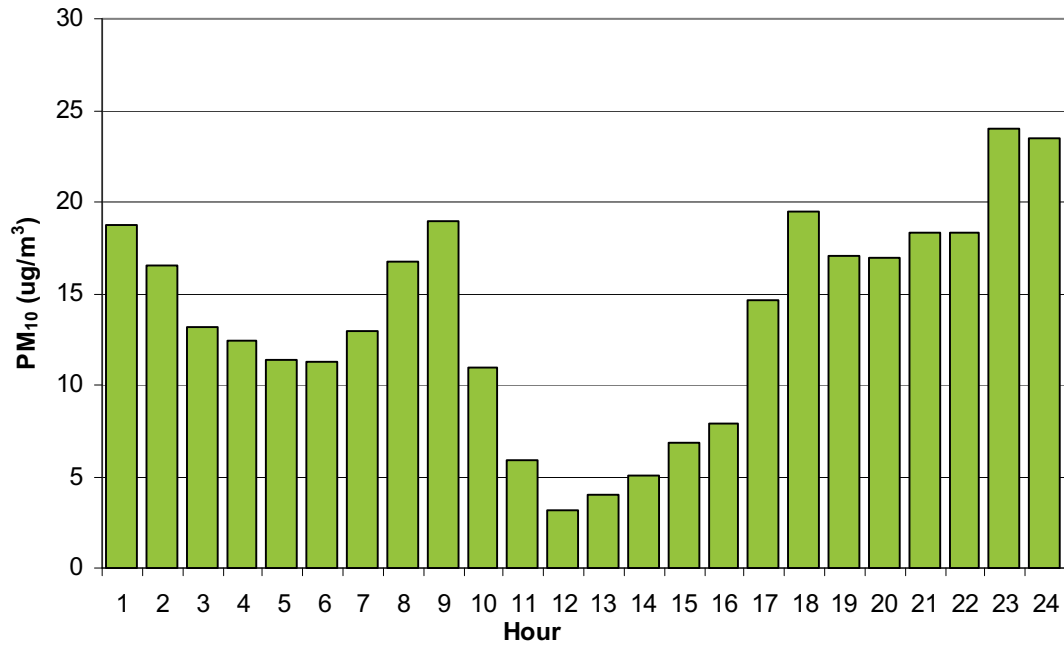

Figure 4.40 Diurnal trends in PM₁₀ at Naseby

4.12 Oamaru

The Oamaru air quality monitor was installed on 18 June 2008. The results of the monitoring are shown in Figure 4.41.

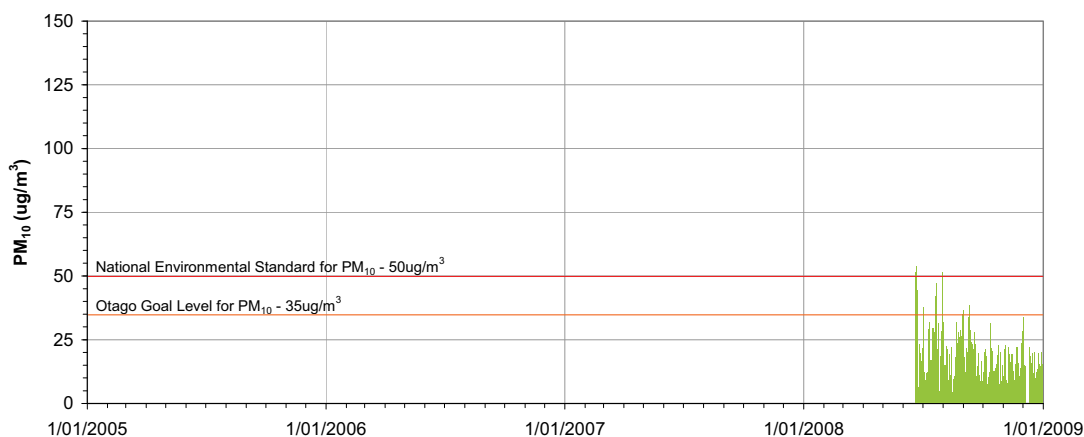

Figure 4.41 Daily PM₁₀ values for Oamaru from June 2008 – December 2008

Since monitoring began, only three exceedances of the AQNES have been recorded. Oamaru is a good example of how a town's location affects its climate and, consequently, its levels of particulates. Comparing emission rates with other Otago towns, on an average winter's day Oamaru emits 2½ times the amount of particulate that Alexandra does. However, during the same period of time monitored (18 June to 31 December) Alexandra had 45 exceedances of the AQNES compared to the three in Oamaru. Summary statistics are shown in Table 4.11.

Table 4.11 Summary statistics for Oamaru (PM₁₀ in µg/m³)

Year	Annual average	Maximum and second highest daily values	Number of high pollution days (>50µg/m ³)	May-Aug Average
2008	-	54 / 52	3	22*
Average	-	54 / 52	3	22*

*only 64% of winter period measured

Of the 14 towns monitored, Oamaru is the one truly coastal centre and, because of that, it experiences a much more moderate climate than inland Otago. Over the course of monitoring in 2008, there were 13 nights in Oamaru where temperatures dipped below 0°C, the coldest night recording -4.1°C. In Alexandra during the same period, there were 56 sub-zero nights, a dozen of which were colder than -4.1°C.

Oamaru also experiences windy conditions more frequently than many other towns due to its proximity to the sea which assists in dispersing particulates. Also, Oamaru does not experience the very strong temperature inversions that other centres do. This can be seen in the average hourly figures shown in Figure 4.42. This graph of a typical day shows a very different trend than most other towns. There appears to be no build-up of particulates during the morning hours and a gradual increase and decrease through the night.

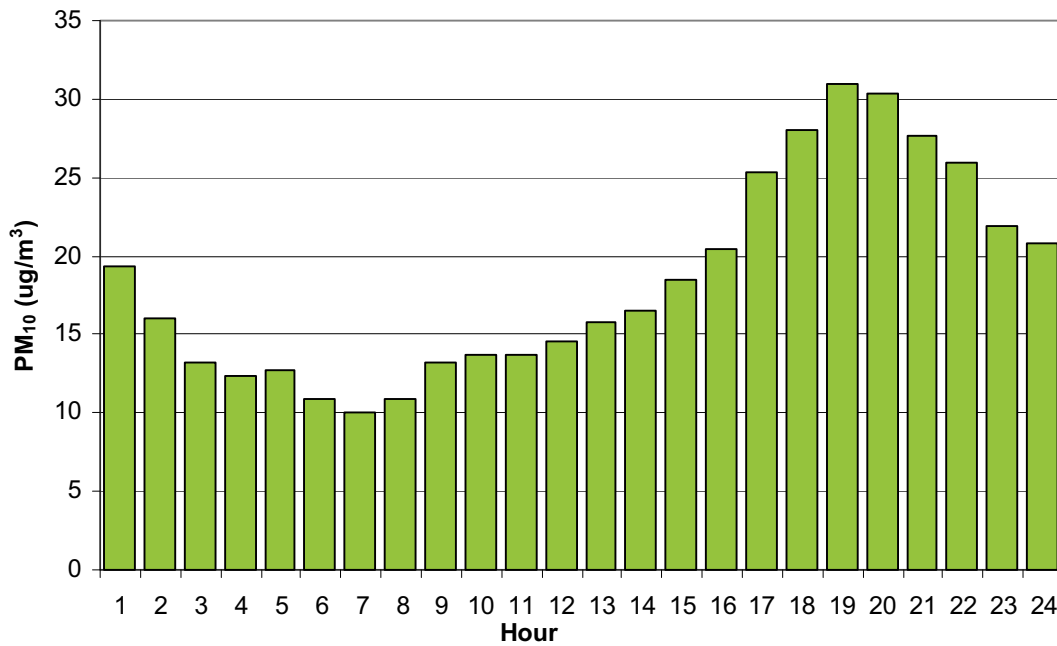

Figure 4.42 Diurnal trends in PM₁₀ at Oamaru

A monthly analysis of the data so far shows that median values for every month are around 20µg/m³ with June experiencing the greatest range in daily PM₁₀ values (Figure 4.43).

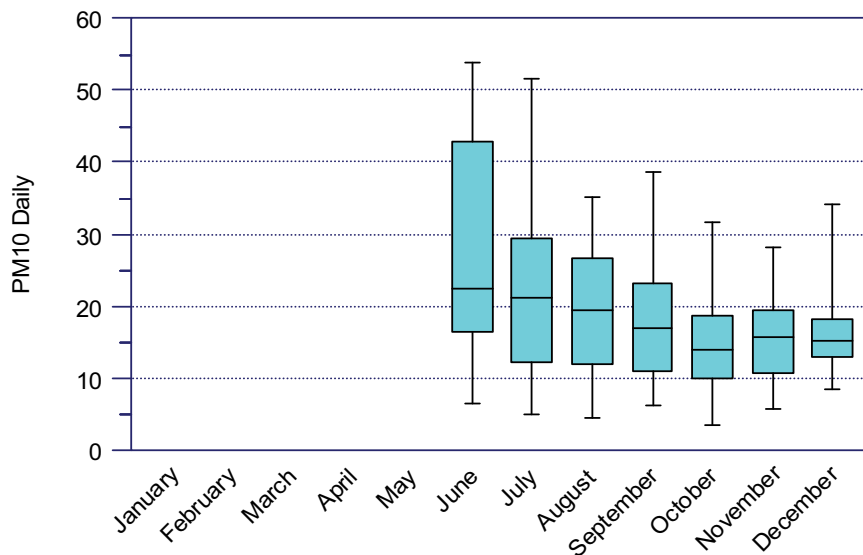

Figure 4.43 Box plots of monthly summary values for Oamaru during 2008

4.13 Ranfurly

Air quality was monitored in Ranfurly during the winters of 2007 and 2008. Results are shown in Figure 4.44 and indicate that Ranfurly does not experience episodes of high pollution. Based on the results, monitoring has been discontinued at Ranfurly.

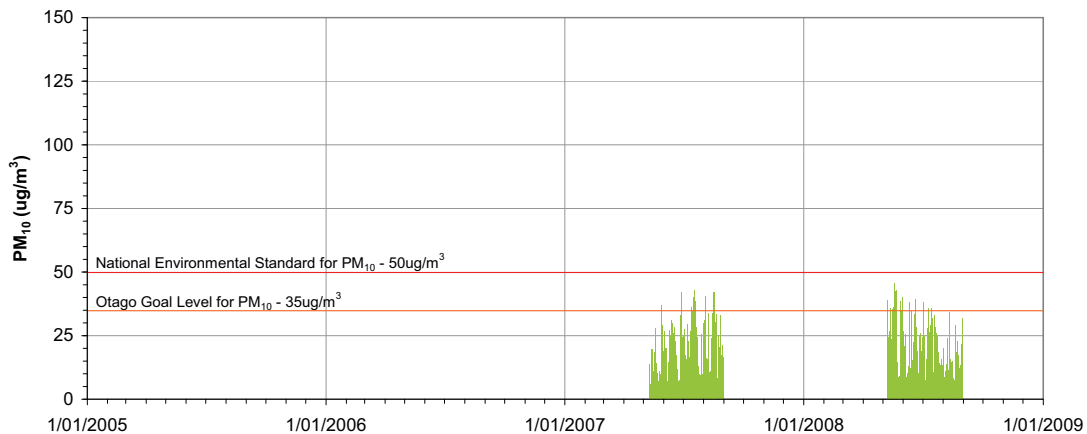

Figure 4.44 Daily PM₁₀ values for Ranfurly during the winters of 2007 and 2008

The average over both winters was $21\mu\text{g}/\text{m}^3$ and neither winter produced any exceedances of the AQNES. For the two winters, the maximum daily PM₁₀ value was $46\mu\text{g}/\text{m}^3$. The summary statistics are shown in Table 4.12.

Table 4.12 Summary statistics for Ranfurly (PM₁₀ in $\mu\text{g}/\text{m}^3$)

Year	Annual average	Maximum and second highest daily values	Number of high pollution days (> $50\mu\text{g}/\text{m}^3$)	May-Aug average
2007	-	43 / 42	0	21
2008	-	46 / 44	0	22
Average	-	45 / 44	0	21

Ranfurly often comes under the influence of high pressure systems during winter months. While this leads to particulate-trapping temperatures inversions, it is apparent that PM₁₀ levels are relatively low in Ranfurly. There may be several explanations for this. First, it is possible there are not sufficient emissions to cause high levels of PM₁₀. Secondly, unlike Alexandra or Arrowtown, Ranfurly is situated on a gently-sloping open plain which may cause particulates to disperse more easily.

The monthly values are shown in Figure 4.45. The greatest variability in PM₁₀ levels occurred in May; August had the least variability. The highest monthly average occurred during July, normally the coldest month in Central Otago.

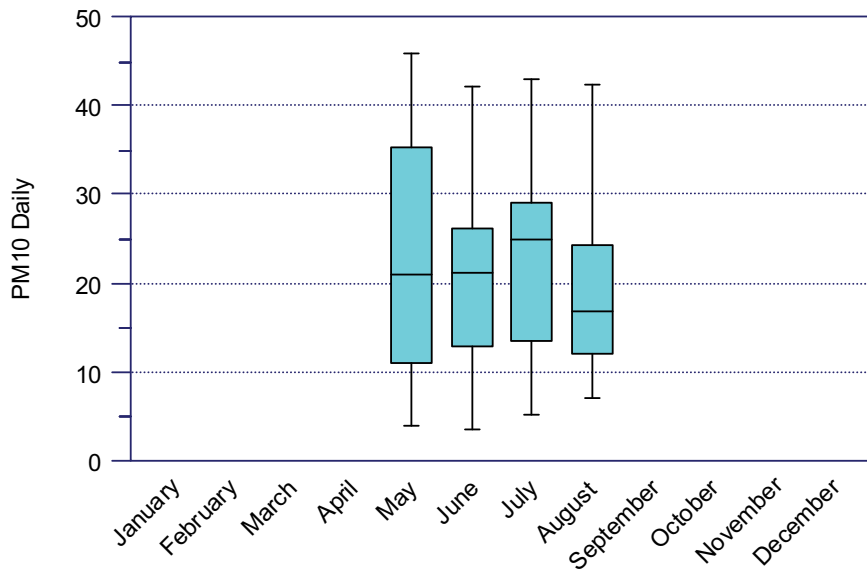

Figure 4.45 Box plots of monthly summary values for Ranfurly during 2007 – 2008

The diurnal trend in Ranfurly is similar to other towns in Central Otago with levels becoming elevated during early evening and remaining high until after midnight (Figure 4.46.)

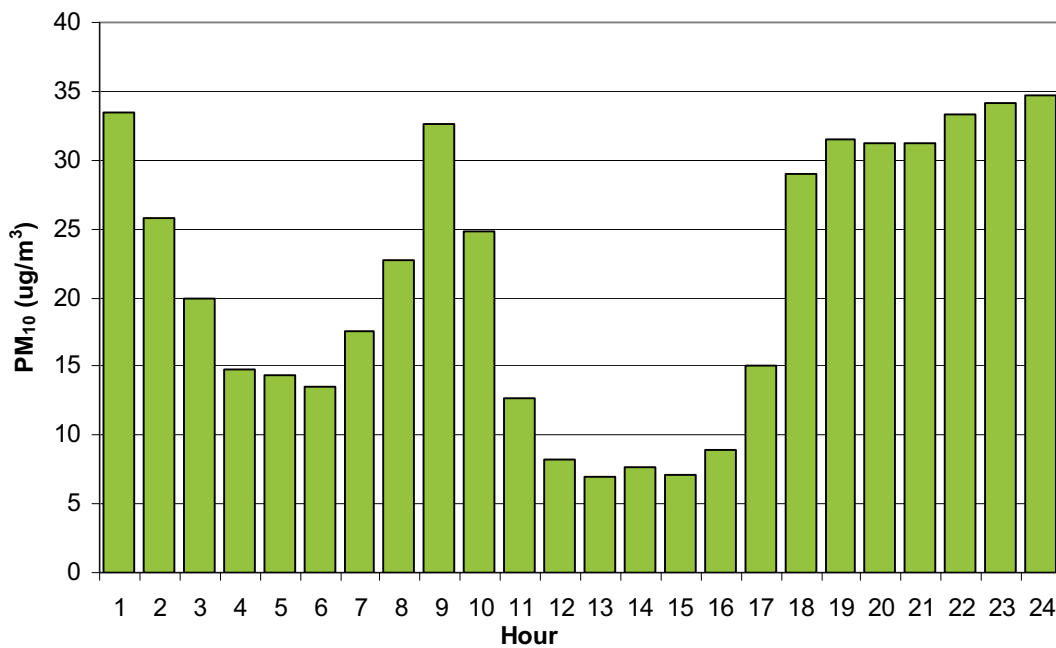

Figure 4.46 Diurnal trends in PM₁₀ at Ranfurly

4.14 Roxburgh

Air quality was monitored in Roxburgh during the winter of 2007. Results of the monitoring are shown in Figure 4.47.

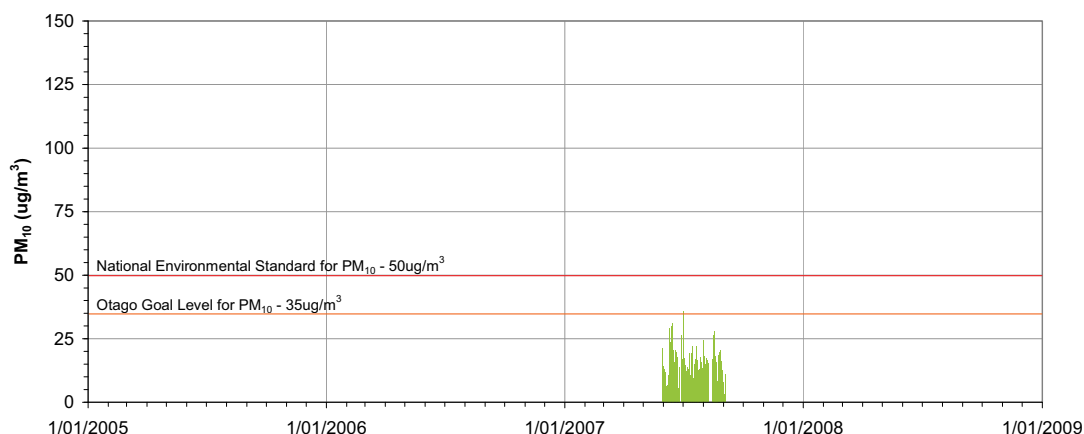

Figure 4.47 Daily PM₁₀ values for Roxburgh during 2007

During this one winter, the air quality was very good in Roxburgh. The highest value recorded for the period was $36\mu\text{g}/\text{m}^3$ on 2 July. This occurred during a relatively calm period before the passage of several fast-moving cold fronts helped to disperse the particulates. The average for the entire monitoring period was $16\mu\text{g}/\text{m}^3$.

June and July temperatures both averaged approximately 5°C , with August warming to an average of 8°C . Overall, the winter average temperature was 7°C . Mid-July experienced the coldest temperatures, often dipping below freezing overnight and staying below 5°C during the day. In comparison to the temperature data recorded at the Roxburgh Power Station from 1971-2000, winter 2007 temperatures were fairly typical.

Despite the cold temperatures, no high pollution days were recorded (Table 4.13). This may be due, in part, to Roxburgh's higher frequency of windy days. Based on these results, monitoring was discontinued at the end of winter.

Table 4.13 Summary statistics for Roxburgh (PM₁₀ in $\mu\text{g}/\text{m}^3$)

Year	Annual average	Maximum and second highest daily values	Number of high pollution days ($>50\mu\text{g}/\text{m}^3$)	May-Aug average
2007	-	36 / 31	0	16
Average	-	36 / 31	0	16

Box plots of the monthly values for Roxburgh (Figure 4.48) show elevated PM₁₀ values from May to August and then a significant decrease during September, typically the shoulder month of winter. Very few days were over the Otago goal level of $35\mu\text{g}/\text{m}^3$.

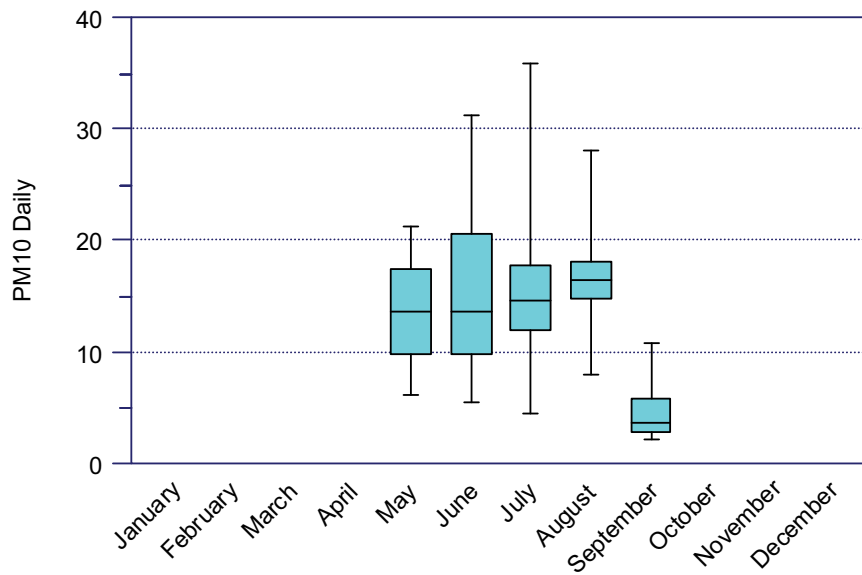

Figure 4.48 Box plots of monthly summary values for Roxburgh from May 2008 to September 2008

The daily pattern of PM₁₀ is shown in Figure 4.49. Very low values were recorded during mid-afternoon, often the time of most convective action in the atmosphere. Levels begin to rise during early evening, presumably as fires are lit and emissions accumulate near the surface.

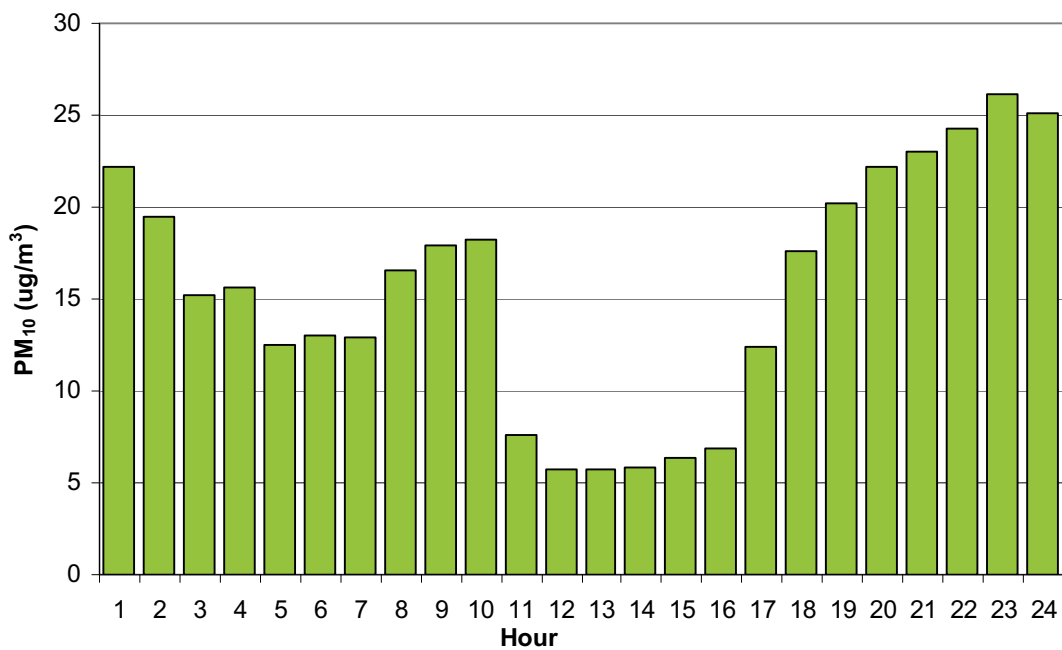

Figure 4.49 Diurnal trends in PM₁₀ at Roxburgh

5. Otago's path to the National Environmental Standard

To measure the progress being made in Otago of reducing PM₁₀ levels to meet the AQNES, the Air Plan establishes annual PM₁₀ limits. When connected over time, these annual targets create a path to achieving compliance by 2013. Since one exceedance a year is allowable, the second highest value of a given year should be less than the target value set for that particular year. Each monitored town has its own path which is designated in the Air Plan as either a straight-line path (SLP) or a curved-line path (CLP).

Towns in Air Zone 1 all have a curved-line path towards compliance in 2013. This allows for the gradual replacement of solid fuel burners with low to no emission options. Starting points for each town are meant to represent typical winter values of PM₁₀ and are effective from 14 April 2007. Where no previous data exist, estimates of these figures were made.

5.1 Alexandra and Arrowtown

Figure 5.1 plots Alexandra's and Arrowtown's second highest values for each year against their CLP. Looking at the difference in the sites' PM₁₀ levels from year to year, it is clear that the weather plays a big part in determining particulate levels, as emissions won't have changed significantly in the last few years.

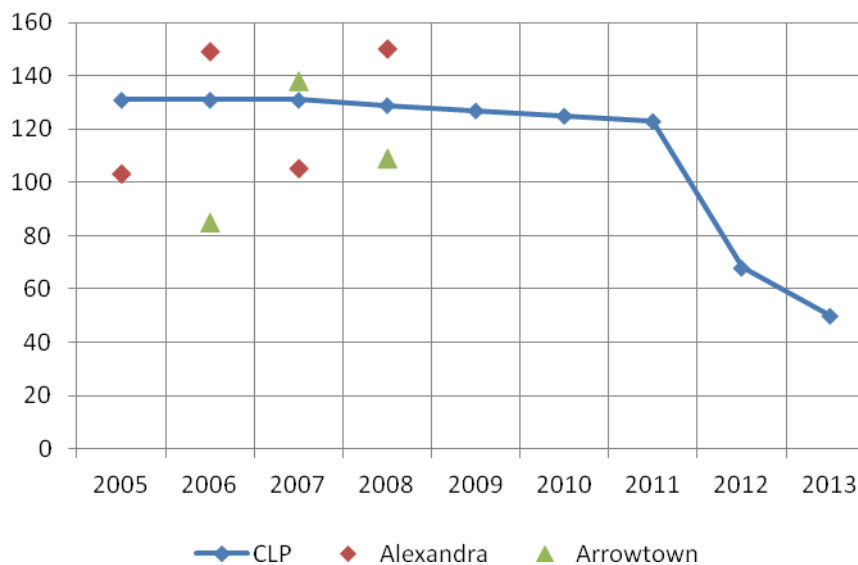

Figure 5.1 Alexandra and Arrowtown's curved-line path is shown in blue and each town's second-highest daily PM₁₀ value is plotted against it

5.2 Clyde

The CLP path for Clyde is shown in Figure 5.2. The first year for which monitoring data are available is 2008 and the second highest value clearly exceeds the target for the year. However, the start point for Clyde was established without the benefit of any prior monitoring.

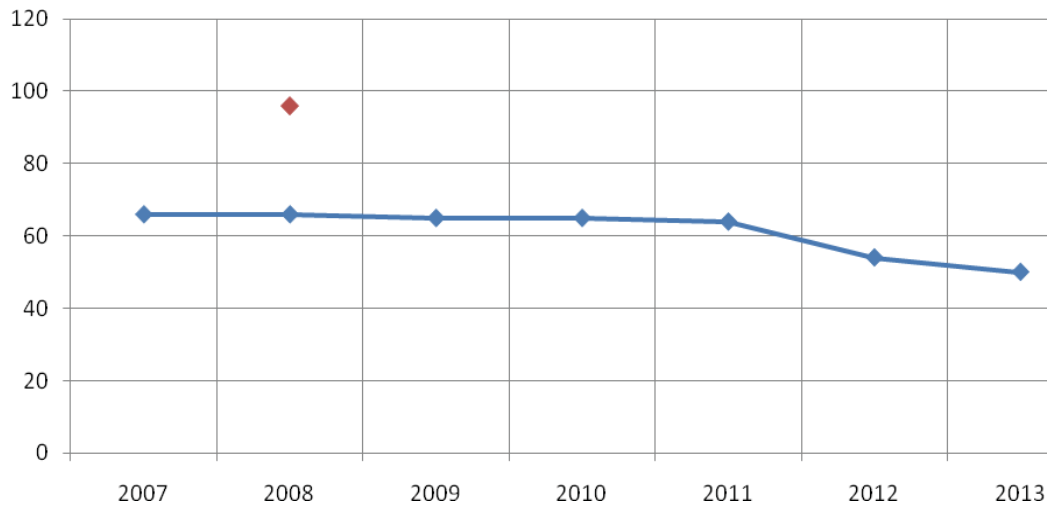

Figure 5.2 Clyde’s CLP plotted with the second highest value in 2008

5.3 Cromwell

Cromwell’s CLP is shown in Figure 5.3. For 2008, the target was not met. Continued monitoring will indicate the progress being made towards compliance with the AQNES in 2013.

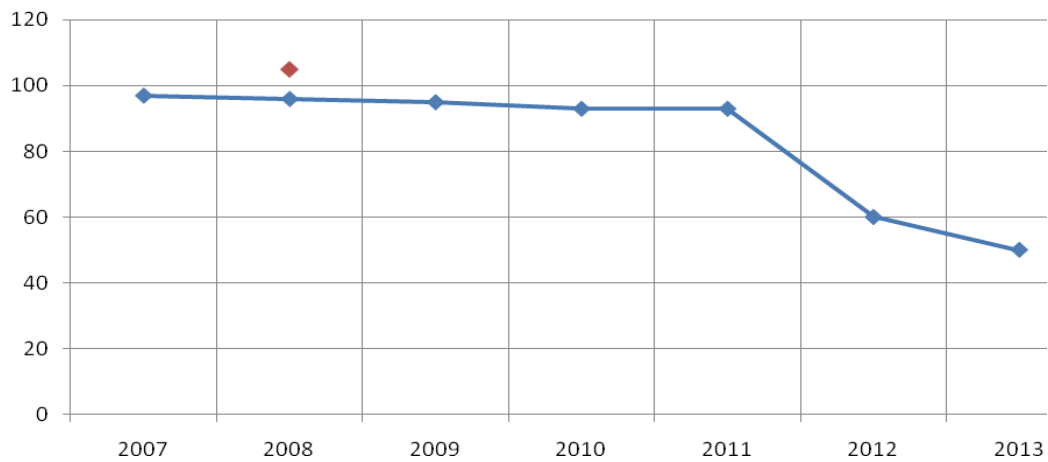

Figure 5.3 Cromwell’s CLP plotted with the second highest value for 2008

5.4 Central Dunedin

For the first time since the SLP was established, Central Dunedin exceeded its target limit of $56\mu\text{g}/\text{m}^3$ with a PM_{10} level of $67\mu\text{g}/\text{m}^3$ recorded on 15 September 2008 (Figure 5.4). As emissions presumably would not have increased significantly from 2007, it is likely that adverse meteorological effects are the cause of elevated PM_{10} . Continued monitoring will indicate the progress being made to compliance with the AQNES in 2013.

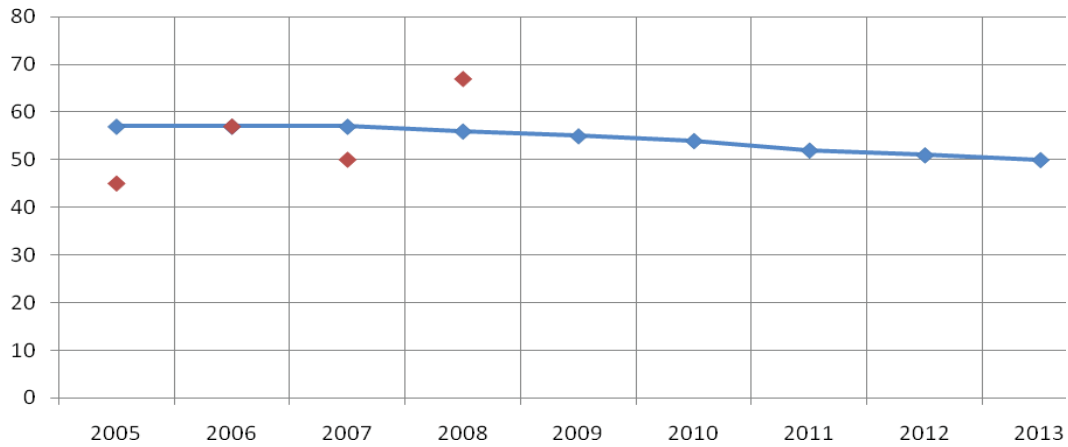

Figure 5.4 Central Dunedin's SLP plotted with each year's second highest value

5.5 Milton

Milton's SLP starting point was established in 2007 without the benefit of prior monitoring data (Figure 5.5). Values were based on town size and geographic location. Clearly, the second highest value exceeded the target for 2008.

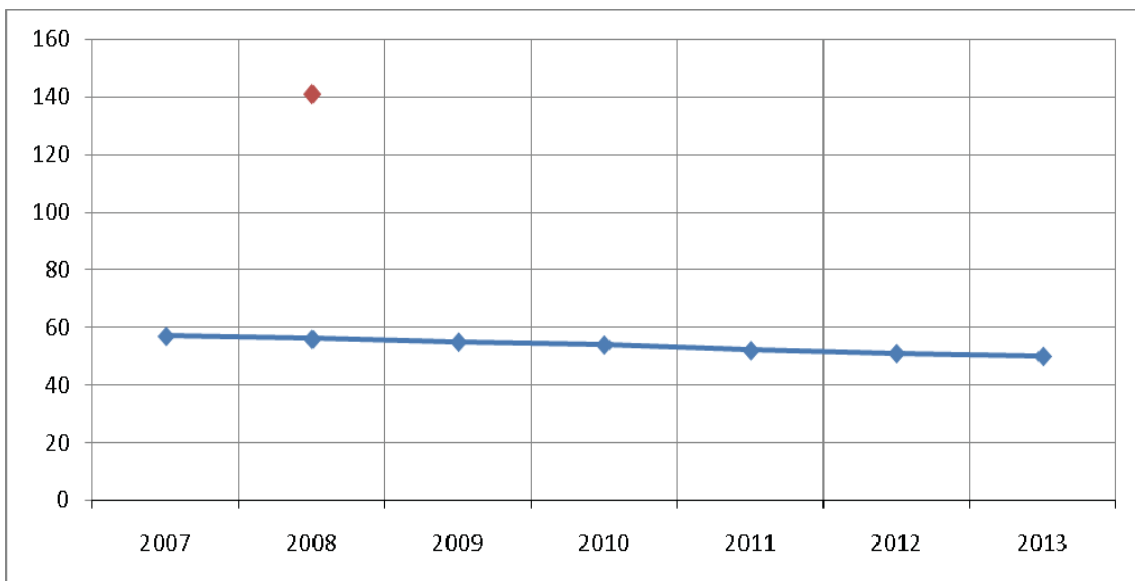

Figure 5.5 Milton's SLP with 2008's second highest value plotted

5.6 Oamaru

Oamaru’s continuous monitoring began in mid-2008 and for this first year, the PM₁₀ target was met (Figure 5.6). Continuous year-round monitoring will continue in Oamaru.

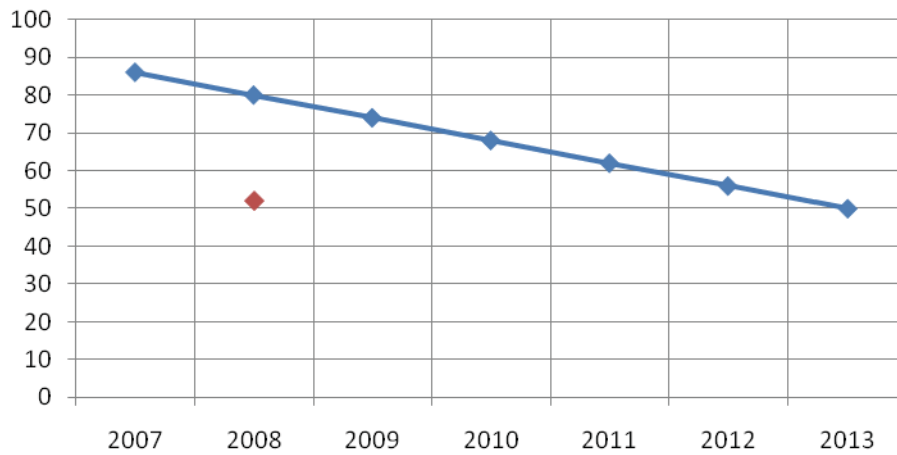

Figure 5.6 Oamaru’s SLP with 2008’s second highest value plotted

5.7 Mosgiel

Since 2006, Mosgiel has achieved its targets in terms of the AQNES (Figure 5.7). In 2008, the target was 78µg/m³ and the second highest value of the year was 77µg/m³. Just as in Central Dunedin, 2008 had second-highest values approximately 20µg/m³ higher than in 2007. This would seem to support the idea that meteorology played a major part in the elevated PM₁₀ levels of 2008.

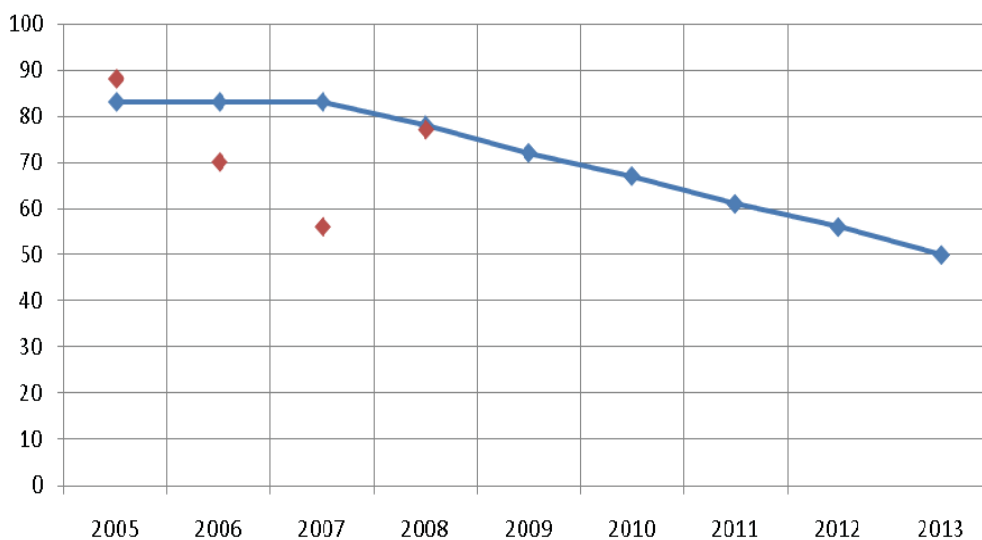

Figure 5.7 Mosgiel’s CLP plotted with each year’s second highest value

The straight-line and curved-line paths are tools established and used by ORC to monitor the region’s progress towards meeting the PM₁₀ air quality standards set by the

Ministry for the Environment. It is still too early to determine trends in the continuous data and clearly meteorology has a large influence on air quality levels.

The next section outlines mitigation measures taken to help communities improve their air quality.

6. Mitigation

In addition to monitoring air quality, the Air Plan sets out objectives and policies for ensuring that air quality in Otago meets acceptable standards for healthy living. Some of these rules are directed at reducing the level of PM₁₀ emitted in Air Zones 1 and 2. These include restrictions on the types of domestic heating appliances that can be installed and used in areas, with different levels of restriction depending on the extent of the air quality issue. The plan also has restrictions on outdoor burning on residential and non-residential properties that, while primarily aimed at nuisance effects, also help to reduce the level of particulates emitted in places that have air quality problems.

Domestic heating appliance rules

The NES for air quality that set limits on the ambient air quality also includes a particulate emission and thermal efficiency standard for wood burners. This standard is set at 1.5 g/kg of particulate emission per dry wood burnt with a thermal efficiency standard of 65%. The Air Plan incorporates this standard in its rules, requiring wood burners to meet the standard if they were installed after 2004 on properties smaller than 2 ha anywhere in Otago.

Further to this, the Air Plan sets more stringent limits on the discharges from home heating appliances in Air Zone 1, recognising these places as having the worst wintertime air quality and requiring the largest reductions in emissions to meet the NES. For new appliances the particulate emission rate is lowered to 0.7g/kg, keeping the 65% thermal efficiency standard. For appliances installed before the plan change was notified in April 2007(or April 2009 in Clyde), a maximum emissions rate of 1.5g/kg applies. The plan allows the use of older non-NES wood and multi-fuel appliances with a particulate emission rate of more than or equal to 1.5 g/kg until 1st January, 2012. After this date older appliances, including multi-fuel burners, will effectively be banned in Air Zone 1 towns.

In Air Zone 2, the rules are less stringent than those in Air Zone 1 but still recognise that air quality can be an issue. For new appliances, the Air Plan extends the NES (1.5g/kg and 65% thermal efficiency) to all appliances on properties of any size within the Air Zone. This effectively bans the installation of multi-fuel and coal burning appliances in these areas with currently the only approved coal burning devices being water heaters. However, if the appliance was installed before the Air Plan change was notified (April 2007), it is allowed provided its discharge is not noxious, dangerous, offensive or objectionable at or beyond the boundary of the property.

The rules for Air Zone 3 are the same for Air Zone 2, but the restrictions only apply to sections smaller than 2ha. Also, an exception has been made to allow cookers on properties under 2ha, with any domestic heating device allowed on sections over 2ha. These rules recognise Air Zone 3 areas as those without significant air quality problems.

In addition to these rules, the Air Plan makes some allowance for appliances in recognised heritage buildings and on commercial premises.

For more information on the rules around domestic heating appliances visit the ORC website www.orc.govt.nz (Plans and publications > Air plan).

Rules for outdoor burning (backyard burning)

The Air Plan sets up a regime that only allows outdoor burning of clean-burning material (paper, cardboard, dry leaves and wood etc) generated on the property, providing that the burning is undertaken in an appropriate location. Because of the relatively high population densities in Air Zone 1 and 2, the Air Plan requires outdoor burning on residential properties in these areas to be undertaken more than 50 metres from the boundary of the property. As most properties are less than 50m across, this effectively does not allow backyard burning in these towns. Because outdoor burning on non-residential properties in Air Zone 1 and 2 is likely to have more significant adverse effects (greater volumes of material are likely to be involved), burning on these properties must be undertaken more than 100 metres from the boundary of the property.

In Air Zone 3, a similar level of control is adopted except that there are no boundary distance guidelines in recognition of the often lower density of development in these areas.

Rules requiring consents for fuel burning equipment (boilers etc)

The Air Plan requires consent for large discharges from fuel burning equipment such as hot water and steam boilers. In Air Zones 1 and 2, consents are required if the burner is over 1 MW, or over 5MW if it only burns clean-burning fuel such as gas. In Air Zone 3, consents are only required for fuel burning equipment over 5MW.

Air Strategy – Clean Heat Clean Air

In addition to the Air Plan, an Air Strategy has been developed to assist the communities in Air Zone 1 (Alexandra, Arrowtown, Clyde and Cromwell) and Milton to meet the air standards. Implementing the air strategy includes ORC assisting the Clean Heat Clean Air programme - a retro-fitting programme involving both insulation and the provision of clean heating appliances in Air Zone 1 and Milton.

In addition, a monthly newsletter, *AirZone*, is distributed to residents in Air Zone 1 and Milton which has information on ways to reduce air quality concerns and encourages clean heating options.

The ORC website www.orc.govt.nz contains all Clean Heat Clean Air publications.

7. References

- ASNZS (2007) Australian Standard, Ambient air – guide for the siting of sampling units. Standard number AS 2922-1987
- ASNZS (2007) Australian/New Zealand Standard, Methods for sampling and analysis of ambient air, Part 1.1: Guide to Siting Air Monitoring equipment. Standard number AS/NZS 3580.1.1:2007
- Fisher, G., T. Kjellstrom, S. Kingham, S. Hales, R. Shrestha., A. Sturman, M. Sherman, C. O’Fallon, J.E Cavanagh and M. Durand. (2007) *Health and Air Pollution in New Zealand: Main report*, Research project prepared for Health Research Council of New Zealand, Ministry for the Environment and Ministry of Transport.
- M. Goldsmith, M. Donaldson, D. Mills, (2007), *Health Affects of Ambient Air Quality in Otago, New Zealand*, Proceedings of the 14th International Union of Air Pollution of the 14th International Union of Air Pollution Prevention and Environmental Protection Associations (IUAPPA) World Congress, 9-13 September 2007, Brisbane.
- ORC (2005a) *Ambient Air Quality in Otago: Particulate Matter, 1997 – 2004*. Otago Regional Council, Dunedin. ISBN 1-877265-20-9.
- ORC (2005b) *Ambient Air Quality in Otago: Nitrogen dioxide, Sulphur Dioxide and Carbon monoxide, 1997 – 2004*. Otago Regional Council, Dunedin. ISBN 1-877265-21-7.
- ORC (2006) *Air Emission Inventory – Dunedin, Mosgiel and Alexandra 2005*, Otago Regional Council, Dunedin. ISBN 1-877265-62-4.
- ORC (2009a) Investigation into the interaction of PM₁₀ emissions from Clyde and Alexandra, report to Environmental Science committee, Otago Regional Council report number 2009/162
- ORC (2009b) Mosgiel Spatial Air Quality, report to Environmental Science committee, Otago Regional Council report number 2009/296
- Osman, J. (2007) Temporal variations in South Dunedin PM₁₀ air pollution. A dissertation submitted in partial fulfilment of the requirements for the degree of Bachelor of Science with Honours, in Geography, at the University of Otago, Dunedin, New Zealand. November 2007.
- Sturman, A. and Tapper, N. (2006) *The Weather and Climate of Australia and New Zealand*. Oxford University Press, New York.
- West, O. (2008) Wintertime PM₁₀ in an Inland Basin, Alexandra, Central Otago, New Zealand. A thesis submitted for the degree of Master of Science at the University of Otago, Dunedin, New Zealand. 22nd December 2008.